

CATALOGO 2026



SINED
DESIGN ACQUA

*INDOOR OUTDOOR
ITALIAN DESIGN
MILANO | BARCELONA*

Catalogo
digitale



INFO@SINEDITALIA.COM

SINEDITALIA.IT
SINEDITALIA.ES
SINEDITALIA.FR
SINEDITALIA.COM

IT +39 022 1117815
IT +39 335 7600875
EN/FR +39 3425447140
ES +34 664 66 64 26
ES +34 664 66 64 28
ES +34 935 05 67 23

SINED

L'ARTE DELL'ACQUA IN ACCIAIO ETERNO

Le docce SINED non sono semplici complementi d'arredo: sono sculture d'acqua in **acciaio inox 316L**, pensate per resistere al tempo e agli elementi atmosferici.

Il nostro design italiano unisce **eleganza minimalista e prestazioni professionali**, dando vita a prodotti che trasformano ogni getto d'acqua in un'esperienza di benessere.

Acciaio nautico 316L, per una bellezza che non arrugginisce mai.

Stile italiano, per ambienti che parlano di classe e raffinatezza.

SINED showers are more than just furnishing accessories: they are **316L stainless steel** water sculptures, designed to withstand time and the atmospheric elements.

Our Italian design combines **minimalist elegance with professional performance**, resulting in products that transform every water jet into a wellness experience.

316L nautical steel, for beauty that never rusts.

Italian style, for environments that speak of class and refinement.

Chi siamo

Nel **1996 Alberto Musso e Denis Gottifredi** fondano MPC Srl, azienda specializzata nella vendita online di marchi prestigiosi. Nel 2020 creano il brand SINED e danno vita a SINED SLU, realtà dedicata a prodotti unici di design.

Fin dalla nascita, SINED si distingue per l'unicità dei suoi prodotti, frutto di una continua ricerca estetica, tecnica e funzionale.

Oggi Sined è un marchio di riferimento in Italia, Spagna e in numerosi altri paesi, specializzato nella produzione di rubinetteria e docce da interno ed esterno in acciaio inox 316L.

Il nostro valore

"Impegno costante e professionalità hanno reso il marchio riconosciuto per l'attenzione ai dettagli, il design innovativo e l'impiego di materiali di eccellenza."

Distribuzione

La nostra rete distributiva si rivolge a:

- Progettisti, architetti e costruttori
- Negozi di termoidraulica e arredo bagno con showroom
- Installatori di piscine
- Professionisti del settore outdoor e dell'interior design

About Us

In 1996, MPC Srl was founded as a company dedicated to the online sale of prestigious brands.

In 2020, driven by the desire to create products that are unique in design and unmatched in quality, Alberto Musso and Denis Gottifredi launched the SINED brand.

From its inception, SINED has stood out for the originality of its products, the result of continuous aesthetic, technical, and functional research.

Today, SINED is a leading brand in Italy, Spain, and many other countries all over the world, specializing in the production of indoor and outdoor showers and faucets made from 316L stainless steel.

Our Value

"Ongoing commitment and professionalism have made the brand renowned for its attention to detail, innovative design, and use of premium-quality materials."

Distribution

Our distribution network serves:

- Designers, architects, and builders
- Plumbing and bathroom furnishing stores with showrooms
- Pool installation professionals
- Outdoor and interior design specialists



OUR COMMITMENT TO THE ENVIRONMENT

At SINED, sustainability is not an abstract concept, but a concrete responsibility that drives every one of our decisions.

We believe that designing and manufacturing with respect for the planet means actively contributing to a better future for all.

Sustainability is a fundamental part of our corporate identity.

Our environmental goals are translated into tangible, measurable actions:

- **Fostering a sustainable culture that engages every team member and attracts talents motivated to make a positive impact.**
All our staff work remotely, helping reduce emissions related to commuting, lower office energy consumption, and minimize the overall environmental footprint of our operations.
- **Developing durable and responsible products that meet customer needs through low-impact solutions.**
We are putting an end to the disposable mindset: our products are designed to stand the test of time, not to be replaced.
Through thoughtful design and easy reparability, we reduce waste, eliminate hidden costs, and lower avoidable environmental impacts.
- **Embedding sustainability principles into our strategic vision, ensuring their practical implementation in operations and shared goals.**

Promoting a conscious and innovative leadership, capable of driving the transition toward a greener economy, while empowering the younger generation and embracing fresh ideas for sustainable change.

We believe sustainability must be expressed through concrete, measurable choices. That's why every detail in our products and processes reflects our responsible vision and the desire to create real, lasting impact.

- **Products built to last:** our faucets are not just functional components, but long-lasting, reliable solutions designed to minimize the need for replacements and promote more responsible resource use.
- **Solutions made for real life:** each of our products is shaped by listening to people and understanding their actual needs.
Design, functionality, and aesthetics come together to deliver versatile, elegant solutions that fit seamlessly into contemporary living spaces.
- **A concrete commitment to reducing environmental impact:** we carefully select materials and employ advanced, responsible production processes to minimize our ecological footprint and foster a more sustainable development model.

IL NOSTRO IMPEGNO PER L'AMBIENTE

In SINED, la sostenibilità non è un concetto astratto, ma una responsabilità concreta che guida ogni nostra scelta.

Crediamo che progettare e produrre con rispetto per il pianeta significhi contribuire attivamente a un futuro migliore per tutti.

La sostenibilità è parte integrante della nostra identità aziendale.

I nostri obiettivi ambientali si traducono in azioni reali e misurabili:

- **Diffondere una cultura sostenibile che coinvolga ogni collaboratore e attragga talenti orientati al cambiamento positivo.**
Tutto il nostro personale opera in modalità *smartworking*, contribuendo a ridurre le emissioni legate agli spostamenti, il consumo energetico degli uffici e l'impatto ambientale complessivo della struttura operativa.
- **Sviluppare prodotti durevoli e responsabili, in grado di soddisfare le esigenze dei clienti con soluzioni a basso impatto.**
Mettiamo fine alla logica dell'usa e getta: i nostri prodotti sono concepiti per accompagnare il tempo, non per essere sostituiti.
Grazie a una progettazione attenta e alla scelta dei materiali, riduciamo gli sprechi, abbattiamo costi superflui e minimizziamo gli impatti ambientali evitabili.
- **Incorporare i principi di sostenibilità nella visione strategica dell'azienda, assicurandone l'applicazione concreta nelle scelte operative e negli obiettivi comuni.**

Promuovere una leadership consapevole e innovativa, capace di guidare la trasformazione verso un'economia più verde, valorizzando il contributo delle nuove generazioni e dando spazio a giovani con idee sostenibili e visioni orientate al cambiamento positivo.

Crediamo che la sostenibilità debba tradursi in scelte concrete, tangibili e misurabili. Per questo, ogni dettaglio dei nostri prodotti e processi riflette la nostra visione responsabile e il desiderio di generare un impatto positivo reale.

- **Prodotti pensati per durare nel tempo:** le nostre rubinetterie in acciaio nautico non sono semplici elementi funzionali, ma soluzioni progettate per offrire lunga durata, alta affidabilità e ridurre la necessità di frequenti sostituzioni, contribuendo così a un uso più consapevole delle risorse.
- **Soluzioni concepite per migliorare la vita quotidiana:** ogni nostro prodotto nasce dall'ascolto delle persone e dei loro bisogni reali. Design, funzionalità ed estetica si uniscono per creare soluzioni versatili, eleganti e perfettamente integrate negli ambienti contemporanei.
- **Un impegno concreto nella riduzione dell'impatto ambientale:** scegliamo con attenzione i materiali e adottiamo processi produttivi avanzati e responsabili, per minimizzare l'impronta ecologica e promuovere un modello di sviluppo più rispettoso del pianeta.

INDICE INDEX

	PAG.				PAG.
DOCCE ACCIAIO INOX 316 L	8-9				
PVD E FINITURE	10-11				
COLLEZIONE LUNA INOX	12-21	MADE IN ITALY			
DOCCIA INOX LUNA D		BREVETTO SINED			
DOCCIA INOX LUNA TMP					
DOCCIA INOX LUNA DOPPIO TMP					
COLLEZIONE LUNA DUO	22-25	MADE IN ITALY			
DOCCE LUNA DUO		BREVETTO SINED			
COLLEZIONE PULA	26-33	MADE IN ITALY			
DOCCE PULA					
DOCCE PULA DUO					
COLLEZIONE PALAU	34-41	MADE IN ITALY			
DOCCE PALAU					
DOCCE PALAU DUO					
COLLEZIONE CHIA	42-47	MADE IN ITALY			
COLLEZIONE QUARTU	48-55	MADE IN ITALY			
DOCCE QUARTU					
DOCCE QUARTU DOPPIO TMP					
DOCCE OROSEI	56-59				
DOCCE ALGHERO	60-63				
DOCCE BOSA	64-67				
DOCCE OLBIA	68-71				
DOCCE BUDONI	72-75				
DOCCE STINTINO	76-79				
DOCCE SASSARI	80-83				
				DOCCE ACQUA FREDDA	84-105
				DOCCIA NORA	
				DOCCIA TEULADA	
				DOCCIA SANTADI	
				DOCCIA SIMIUS	
				DOCCIA PALAU FREDDA	
				RUBINETTI ALTI FREESTANDING	106-113
				DOCCIA ORISTANO	
				DOCCIA CALASETTA	
				DOCCIA CARLOFORTE	
					114-133
				DOCCE DA PARETE	
				DOCCE DA PARETE LEVANTE	
				DOCCE DA PARETE ARBOREA & CABRAS	
				DOCCE DA PARETE CHIA & PULA	
				DOCCE PROFESSIONALI	134-149
				DOCCIA POLIFEMO	
				DOCCIA ORTRO 2T	
				DOCCIA CERBERO 3T	
				DOCCIA IDRA 4T	
				DOCCIA MONOCOLO	
				DOCCIA BICEFALO	
				RUBINETTI ACCIAIO INOX 316L	150-249
				RUBINETTO LAVABO	
				RUBINETTO LAVELLO	
				RUBINETTERIA DA PARETE	
				DOCCETTE E DOCCINI	
				SOFFIONI E KIT	
				ACCESSORI PER IL BAGNO	
				VASCHE & LAVANDINI	250-267
				LAVANDINO	
				VASCA	
				DOCCE LUNA ALLUMINIO	268-281
				LUNA-ALU	
				LUNA-TIMER	
				SCHEDE TECNICHE	282-291
				SINED NEL MONDO	292-293
				CONDIZIONI DI FORNITURA	294-295

DOCCE IN ACCIAIO INOX NAUTICO 316L

316L NAUTICAL STAINLESS STEEL SHOWERS

Le docce Sined in acciaio inox 316L dall'elegante design innovativo e moderno sono studiate anche per un utilizzo in ambiente marino e termale.

Le docce sono dotate di un collegamento a terra tramite speciale sistema di fissaggio brevettato C-BOX per collegare acqua calda e fredda.

Le docce Sined si compongono di due metà, facilmente assemblabili, riposte all'interno di una robusta confezione da 120cm per facilitarne il trasporto e lo stoccaggio.

Le docce si rimuovono facilmente dal C-BOX e possono essere conservate all'interno della sacca protettiva in dotazione.

I ricambi sono disponibili per essere spediti in 24/48 ore.

The Sined 316L stainless steel showers with their innovative and modern design are also designed for use in marine and spa environments.

The showers are equipped with a special patented C-BOX ground connection to connect hot and cold water.

The Sined showers consist of two halves, which can be easily assembled and are stored inside a sturdy 120 cm box for easy transport and storage.

The showers are easily removed from the C-BOX and can be stored inside the protective bag.

Spare parts are available for dispatch within 24/48 hours.



Cos'è l'acciaio inox 316L e perché SINED lo ha scelto per le sue docce

L'acciaio inox 316L è una lega austenitica di altissima qualità, composta principalmente da ferro, cromo, nichel e molibdeno. Quest'ultimo elemento — il molibdeno — è ciò che distingue il 316L da altri tipi di acciaio, conferendogli una resistenza superiore alla corrosione, soprattutto in ambienti aggressivi come zone marine o con forte umidità.

La sigla "L" indica il basso contenuto di carbonio (Low Carbon), che riduce la formazione di carburi e previene la corrosione intergranulare, rendendo l'acciaio ancora più affidabile nel tempo anche dopo saldature o lavorazioni meccaniche.

Perché SINED ha scelto l'inox 316L per le sue docce

Massima resistenza alla corrosione: Ideale per l'uso all'aperto, vicino al mare o in piscine, l'acciaio 316L non si deteriora a contatto con salsedine, cloro o umidità costante.

Estetica duratura: La sua superficie rimane brillante e inalterata anche dopo anni di esposizione agli agenti atmosferici.

Sicurezza e igiene: È un materiale antibatterico e facile da pulire, perfetto per un utilizzo quotidiano in ambienti sensibili.

Alta lavorabilità: L'acciaio 316L consente lavorazioni precise, finiture di pregio e integrazione con trattamenti avanzati come la colorazione PVD.

Scelta sostenibile: Completamente riciclabile e a basso impatto ambientale, si inserisce perfettamente nella filosofia SINED orientata alla qualità e al rispetto per l'ambiente.

What is 316L Stainless Steel and Why SINED Chose It for Its Outstanding Showers

316L stainless steel is a high-grade austenitic alloy composed mainly of iron, chromium, nickel, and molybdenum. The presence of molybdenum is what sets 316L apart from other stainless steels, giving it enhanced resistance to corrosion, especially in harsh environments such as coastal or high-humidity areas.

The "L" stands for Low Carbon, which minimizes carbide precipitation and prevents intergranular corrosion — making the steel even more reliable over time, even after welding or mechanical processing.

Why SINED Chose 316L Stainless Steel for Its Showers

Exceptional corrosion resistance: Perfect for outdoor use, near the sea, or around swimming pools — 316L steel withstands salt, chlorine, and constant moisture without deterioration.

Long-lasting aesthetics: Its surface remains bright and unchanged even after years of exposure to the elements.

Hygienic and safe: Naturally antibacterial and easy to clean, making it ideal for daily use in sensitive environments.

High workability: 316L steel allows for precise machining, premium finishes, and is fully compatible with advanced treatments such as PVD coating.

A sustainable choice: Fully recyclable and environmentally friendly, it aligns perfectly with SINED's philosophy of quality and ecological responsibility.

TRATTAMENTO PVD

PVD TREATMENT

Cos'è il PVD e perché lo utilizziamo sulle nostre docce in acciaio inox 316L

Il PVD (Physical Vapor Deposition) è un avanzato processo fisico di deposizione da fase vapore che consente di applicare sottilissimi rivestimenti metallici su superfici solide, senza alterare la struttura dell'oggetto trattato.

Nel caso delle docce SINED in acciaio inox 316L, il PVD viene utilizzato per conferire colorazioni eleganti, omogenee e altamente resistenti, migliorando non solo l'estetica del prodotto, ma anche le sue prestazioni nel tempo.

Vantaggi della colorazione PVD sulle docce SINED

Resistenza superiore: Il rivestimento ottenuto con PVD è estremamente resistente a graffi, corrosione, agenti atmosferici e prodotti chimici, rendendolo ideale per ambienti esterni e marini.

Finitura estetica impeccabile: Le superfici colorate mantengono una lucentezza uniforme e duratura, valorizzando il design moderno ed essenziale delle docce SINED.

Ecocompatibilità: Il processo PVD è pulito, privo di sostanze inquinanti e solventi chimici, in linea con la nostra filosofia di produzione sostenibile.

Adesione perfetta sull'acciaio inox 316L: Grazie alla sua struttura austenitica, l'acciaio 316L è perfettamente compatibile con il trattamento PVD, garantendo stabilità del colore e durata nel tempo.

What is PVD and Why We Use It on Our 316L Stainless Steel Showers

PVD (Physical Vapor Deposition) is an advanced physical coating process that allows the application of ultra-thin metallic layers onto solid surfaces without altering the structure of the treated object.

For SINED showers made of 316L stainless steel, PVD is used to achieve elegant, uniform, and highly durable color finishes, enhancing both the aesthetic appeal and long-term performance of the product.

Benefits of PVD Coating on SINED Showers

Superior durability: The PVD coating is exceptionally resistant to scratches, corrosion, weather conditions, and chemicals, making it ideal for outdoor and marine environments.

Flawless aesthetic finish: The colored surfaces maintain a consistent and long-lasting shine, elevating the sleek and modern design of SINED showers.

Eco-friendly process: PVD is a clean, environmentally responsible technology that uses no pollutants or harmful solvents, in line with our commitment to sustainable manufacturing.

Perfect adhesion on 316L stainless steel: Thanks to its austenitic structure, 316L steel is perfectly compatible with PVD treatment, ensuring stable coloration and long-lasting results.

FINITURE

FINISHES



Bianco
Metal White



Canna Fucile
Brushed Gun Grey



Inox
Brushed

PVD



Nero
Brushed Black

PVD



Oro Rosa
Brushed Rose Gold

PVD



Oro
Brushed Gold

PVD

DOCCE INOX LUNA

Eleganza marina senza tempo

Progettata per dialogare con l'esterno attraverso linee pure e proporzioni equilibrate. LUNA esprime un linguaggio formale che unisce eleganza e prestazioni tecniche. Realizzata in acciaio inox marino AISI 316L, resiste con naturalezza agli agenti atmosferici. Disponibile con doccino o in versione temporizzata, offre comfort e funzionalità su misura. La finitura satinata e le connessioni nascoste ne esaltano l'essenzialità estetica. Una presenza discreta ma decisa, ideale per spazi privati e contesti professionali.

Timeless marine elegance

Designed to harmonize with outdoor environments through pure lines and balanced proportions. LUNA speaks a formal language that unites refined elegance with technical performance. Crafted in marine-grade AISI 316L stainless steel, it naturally endures atmospheric exposure. Available with a hand shower or in a timed version, it delivers tailored comfort and functionality. Satin finish and hidden connections enhance its essential aesthetic. A subtle yet confident presence, ideal for private spaces and professional settings.



COLLEZIONE

LUNA-INOX

OPZIONI DI COLORE
COLOR OPTIONS

MADE IN ITALY
BREVETTO ITALIANO



White
Bianco

Brushed
Inox Spazzolato

Black
Nero
PVD

Gold
Oro
PVD

Rose Gold
Oro Rosa
PVD

DOCCIA-INOX-LUNA-D

MADE IN ITALY

STOCK



INOX 8025431153141

PVD **CANNA-FUCILE** 8025431156845

PVD **ORO-ROSA** 8025431153202

PVD **NERA** 8025431153172 *

PVD **ORO** 8025431153189 *

BIANCA 8025431153196 *

*DISPONIBILE SOLO SU ORDINAZIONE

*AVAILABLE ONLY UPON REQUEST

CARATTERISTICHE

- **MATERIALE ACCIAIO INOX 316L / 316L STAINLESS STEEL**
- **UGELLI ANTICALCARE / ANTI LIMESCALE NOZZLES**
- **ACCESSORI IN ACCIAIO INOX 316L / STAINLESS STEEL 316L**
- **PESO/WEIGHT 13 KG**
- **PACKAGING 130X32X18 CM**
- **GETTO D'ACQUA / WATER JET VERTICALE**
- **INCLUDE SACCA DI PROTEZIONE/PROTECTION BAG**
- **ACQUA CALDA E FREDDA / WATER HOT AND COLD**

SISTEMA DI FISSAGGIO/FIXING SYSTEM

4 VITI IN ACCIAIO/4 STEEL SCREWS A2-70 15,5CM INCLUDED



**WORLD WIDE SINED EXCLUSIVE!
ESCLUSIVA MONDIALE SINED!**

DOUBLE WATER INLET SIDE OR BOTTOM

PREDISPOSTA PER 2 TIPI DI COLLEGAMENTO LATERALE O INFERIORE

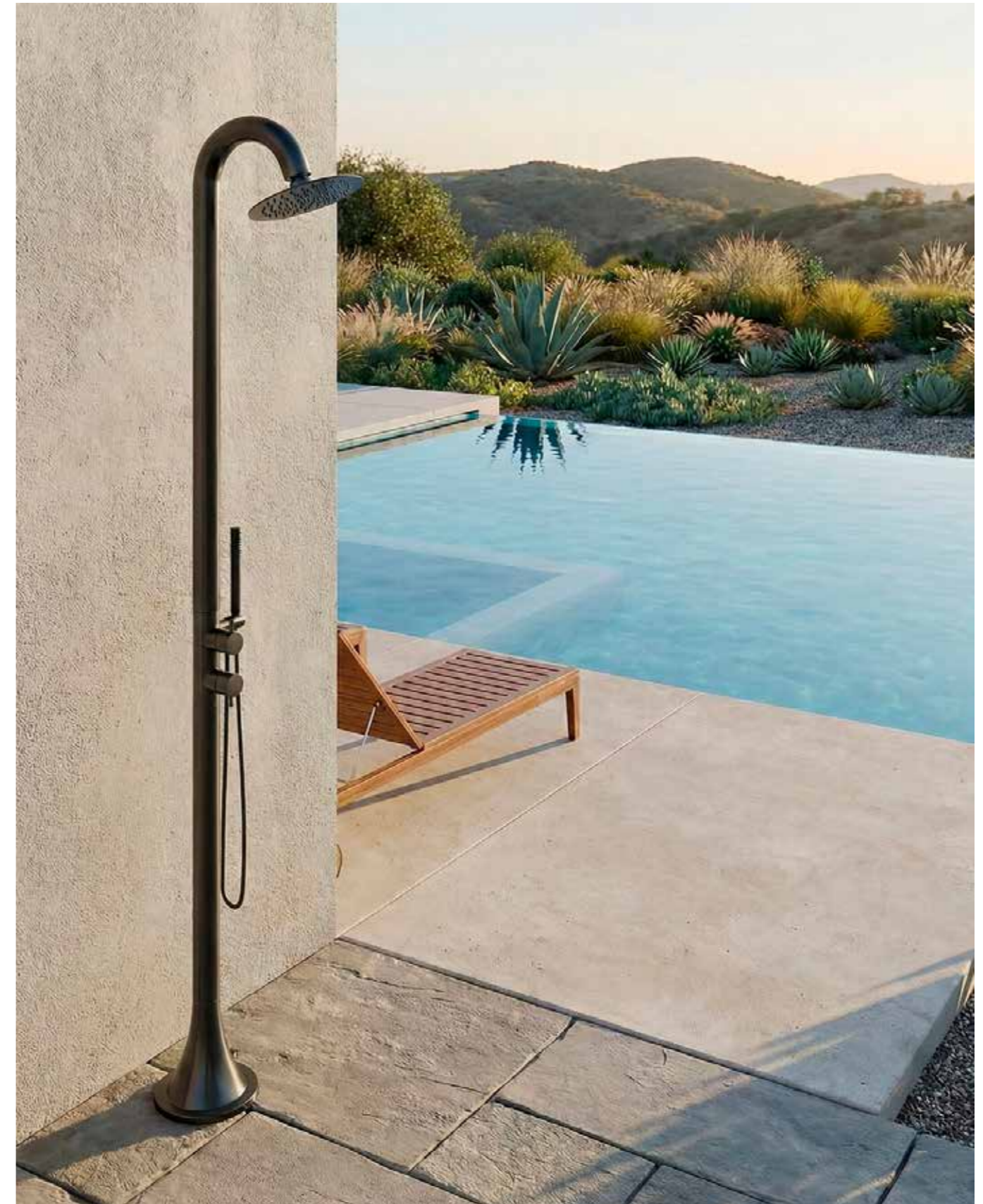
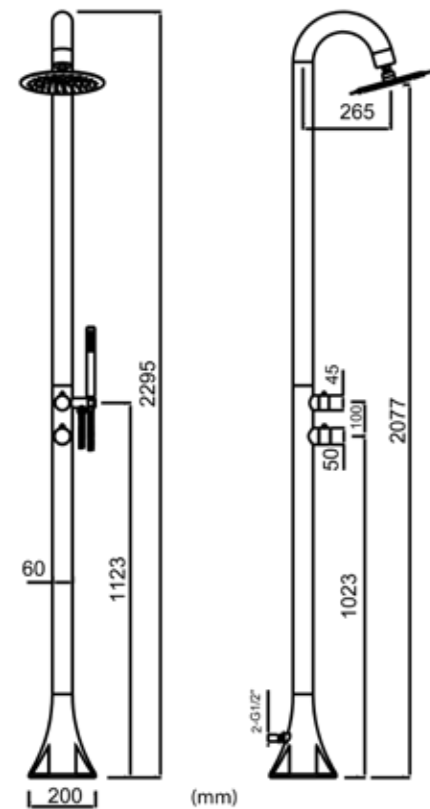
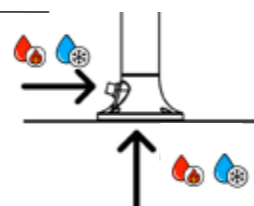

DOCCIA-INOX-LUNA-TMP

MADE IN ITALY

STOCK



 **INOX** 8025431153158

PVD  **ORO-ROSA** 8025431155497



CARATTERISTICHE

- **MATERIALE ACCIAIO INOX 316L / 316L STAINLESS STEEL**
- **UGELLI ANTICALCARE / ANTI LIMESCALE NOZZLES**
- **ACCESSORI IN ACCIAIO INOX 316L / STAINLESS STEEL 316L**
- **PESO/WEIGHT 13 KG**
- **PACKAGING 130X32X18 CM**
- **GETTO D'ACQUA / WATER JET VERTICALE**
- **INCLUDE SACCA DI PROTEZIONE/PROTECTION BAG**
- **ACQUA FREDDA O PREMISCELATA / WATER COLD OR PREMIXED**

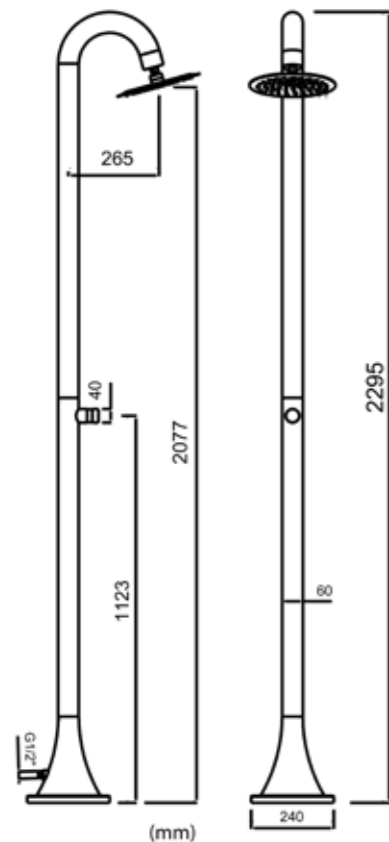

SISTEMA DI FISSAGGIO/FIXING SYSTEM
4 VITI IN ACCIAIO/4 STEEL SCREWS A2-70 15,5CM
INCLUDED



**WORLD WIDE SINED EXCLUSIVE!
ESCLUSIVA MONDIALE SINED!**

**DOUBLE WATER INLET SIDE OR
BOTTOM**

**PREDISPOSTA PER 2 TIPI DI
COLLEGAMENTO LATERALE O
INFERIORE**

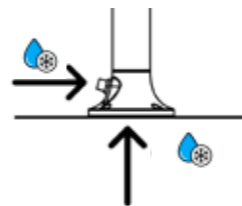

DOCCIA-INOX-LUNA-DOPPIO-TMP

MADE IN ITALY

STOCK



INOX 8025431157842

PVD CANNA-FUCILE 8025431159273

PVD ORO-ROSA 8025431157866

PVD NERA 8025431157859 *

PVD ORO 8025431159266 *

*DISPONIBILE SOLO SU ORDINAZIONE
*AVAILABLE ONLY UPON REQUEST

CARATTERISTICHE

- **MATERIALE** ACCIAIO INOX 316L / 316L STAINLESS STEEL
- **UGELLI ANTICALCARE / ANTI LIMESCALE NOZZLES**
- **ACCESSORI** IN ACCIAIO INOX 316L / STAINLESS STEEL 316L
- **PESO/WEIGHT** 13 KG
- **PACKAGING** 130X32X18 CM
- **GETTO D'ACQUA / WATER JET** VERTICALE
- **INCLUDE** SACCA DI PROTEZIONE/PROTECTION BAG
- **FUNZIONE/FUNCTION** TIMER
- **ACQUA FREDDA O PREMISCELATA / WATER COLD OR PREMIXED**

SISTEMA DI FISSAGGIO/FIXING SYSTEM
4 VITI IN ACCIAIO/4 STEEL SCREWS A2-70 15,5CM INCLUDED



**WORLD WIDE SINED EXCLUSIVE!
ESCLUSIVA MONDIALE SINED!**

**DOUBLE WATER INLET SIDE OR
BOTTOM**

**PREDISPOSTA PER 2 TIPI DI
COLLEGAMENTO** LATERALE O
INFERIORE

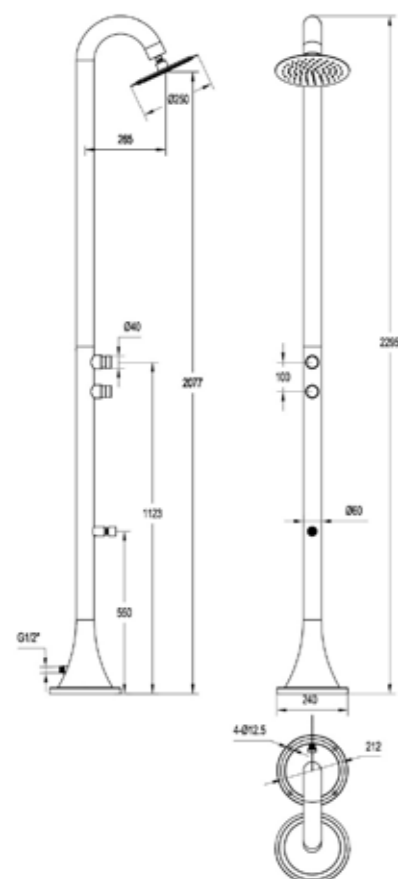
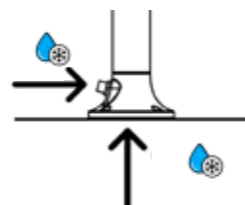

COLLEZIONE

LUNA-DUO

OPZIONI DI COLORE
COLOR OPTIONS

*I prodotti della linea duo possono essere personalizzati su richiesta
** The products in the duo line can be customised on request.*

MADE IN ITALY
BREVETTO ITALIANO



Bianco + Nero

Inox Spazzolato + Nero

Nero + Inox
PVD

Nero + Oro
PVD

Nero + Oro Rosa
PVD

DOCCIA-LUNA-DUO

MADE IN ITALY



STOCK

INOX-NERA 8025431157651

PVD NERA-ORO-ROSA 8025431157699

PVD NERA-INOX 8025431157668 *

PVD NERA-ORO 8025431157682 *

BIANCA-NERA 8025431157675 *

*DISPONIBILE SOLO SU ORDINAZIONE

*AVAILABLE ONLY UPON REQUEST

CARATTERISTICHE

- **MATERIALE ACCIAIO INOX 316L / 316L STAINLESS STEEL**
- **UGELLI ANTICALCARE / ANTI LIMESCALE NOZZLES**
- **ACCESSORI IN ACCIAIO INOX 316L / STAINLESS STEEL 316L**
- **PESO/WEIGHT 13 KG**
- **PACKAGING 130X32X18 CM**
- **GETTO D'ACQUA / WATER JET VERTICALE**
- **INCLUDE SACCA DI PROTEZIONE/PROTECTION BAG**
- **ACQUA CALDA E FREDDA / WATER HOT AND COLD**

SISTEMA DI FISSAGGIO/FIXING SYSTEM

4 VITI IN ACCIAIO/4 STEEL SCREWS A2-70 15,5CM INCLUDED



**WORLD WIDE SINED EXCLUSIVE!
ESCLUSIVA MONDIALE SINED!**

DOUBLE WATER INLET SIDE OR BOTTOM

PREDISPOSTA PER 2 TIPI DI COLLEGAMENTO LATERALE O INFERIORE

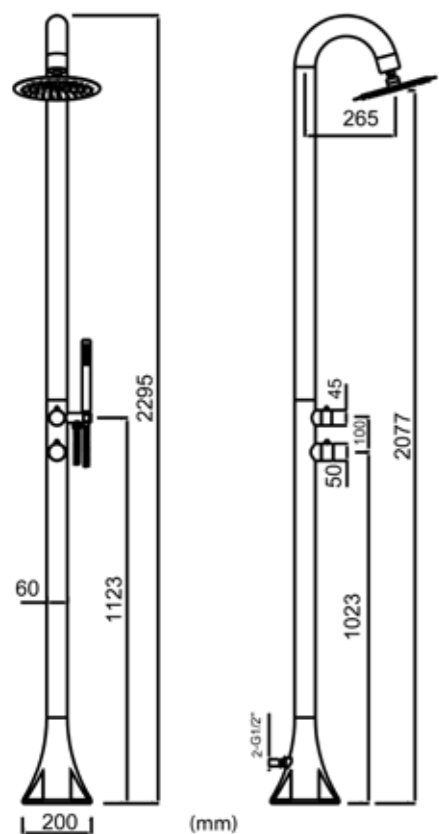
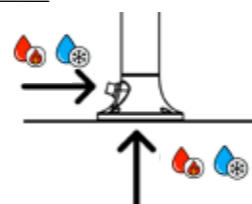

DOCCIA PULA

Eleganza funzionale in acciaio marino

Con una silhouette slanciata e linee essenziali, DOCCIA-PULA ridefinisce la doccia outdoor come oggetto di design puro. Realizzata in acciaio inox AISI 316L, assicura resistenza superiore in ambienti salini e umidi. La finitura satinata esalta la purezza formale, mentre l'integrazione di doccetta, doppio miscelatore e connessioni nascoste offre un'esperienza d'uso intuitiva e sofisticata. Un elemento che si armonizza con giardini, spa e spazi contract, apportando carattere e distinzione.

Functional elegance in marine-grade steel

With a slender silhouette and clean lines, DOCCIA-PULA redefines the outdoor shower as a pure design object. Crafted from AISI 316L stainless steel, it ensures superior resistance in saline and humid environments. The satin finish enhances its formal purity, while the integration of a hand shower, dual mixer, and concealed connections provides an intuitive and sophisticated user experience. A piece that harmonizes with gardens, spas, and contract spaces, bringing character and distinction.



COLLEZIONE

PULA + DUO

OPZIONI DI COLORE
COLOR OPTIONS

*I prodotti della linea duo possono essere personalizzati su richiesta
** The products in the duo line can be customised on request.*

MADE IN ITALY
BREVETTO ITALIANO



DOCCIA-PULA

MADE IN ITALY 

STOCK

 INOX 8025431016781

PVD  NERA 8025431016828

CARATTERISTICHE

- **MATERIALE ACCIAIO INOX 316L / 316L STAINLESS STEEL**
- **UGELLI ANTICALCARE / ANTI LIMESCALE NOZZLES**
- **ACCESSORI IN ACCIAIO INOX 316L / STAINLESS STEEL 316L**
- **PESO/WEIGHT 15,5**
- **PACKAGING 129X56X27 CM**
- **GETTO D'ACQUA / WATER JET VERTICALE**
- **INCLUDE SACCA DI PROTEZIONE/PROTECTION BAG**
- **DEVIATORE A DUE VIE PER SOFFIONE E DOCCETTA
TWO-WAY DIVERTER FOR HEAD AND HAND SHOWER**
- **ACQUA CALDA E FREDDA / WATER HOT AND COLD**



SISTEMA DI FISSAGGIO/FIXING SYSTEM C-BOX

*ULTERIORI INFORMAZIONI
*MORE INFORMATION PAG 283



SCANSIONA PER VEDERE IL VIDEO DEL
MONTAGGIO
SCAN TO VIEW THE **ASSEMBLY VIDEO**



DOCCIA-PULA-DUO

MADE IN ITALY 

STOCK

 **INOX-NERA** 8025431157705

 **NERA-INOX** 8025431157712

PVD  **NERA-ORO** 8025431157729 *

PVD  **NERA-ORO-ROSA** 8025431157736 *

*DISPONIBILE SOLO SU ORDINAZIONE

*AVAILABLE ONLY UPON REQUEST

CARATTERISTICHE

- **MATERIALE ACCIAIO INOX 316L / 316L STAINLESS STEEL**
- **UGELLI ANTICALCARE / ANTI LIMESCALE NOZZLES**
- **ACCESSORI IN ACCIAIO INOX 316L / STAINLESS STEEL 316L**
- **PESO/WEIGHT 15,5**
- **PACKAGING 129X56X27 CM**
- **GETTO D'ACQUA / WATER JET VERTICALE**
- **INCLUDE SACCA DI PROTEZIONE/PROTECTION BAG**
- **DEVIATORE A DUE VIE PER SOFFIONE E DOCGETTA
TWO-WAY DIVERTER FOR HEAD AND HAND SHOWER**
- **ACQUA CALDA E FREDDA / WATER HOT AND COLD**



SISTEMA DI FISSAGGIO/FIXING SYSTEM C-BOX

*ULTERIORI INFORMAZIONI

*MORE INFORMATION PAG 283



SCANSIONA PER VEDERE IL VIDEO DEL MONTAGGIO
SCAN TO VIEW THE ASSEMBLY VIDEO

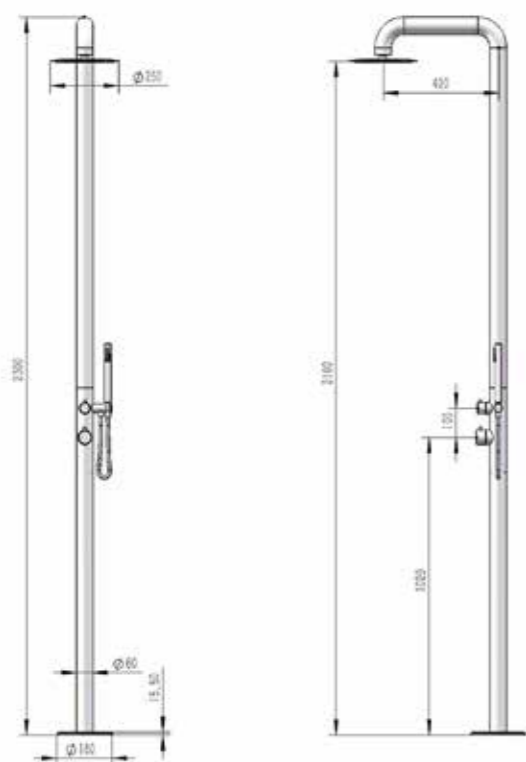

DOCCIA PALAU

Equilibrio tra eleganza e funzionalità

Con una silhouette curva e linee essenziali, DOCCIA-PALAU ridefinisce la doccia outdoor come oggetto di design puro. Realizzata in acciaio inox AISI 316L, assicura resistenza superiore in ambienti salini e umidi. La finitura satinata esalta la purezza formale, mentre l'integrazione di lavapiedi, doppio miscelatore e connessioni nascoste offre un'esperienza d'uso intuitiva e sofisticata. Un elemento che si armonizza con giardini, spa e spazi contract, apportando carattere e distinzione.

Balance between elegance and functionality

With a curved and refined silhouette, DOCCIA-PALAU redefines the outdoor shower as a pure design object. Crafted from AISI 316L stainless steel, it ensures superior resistance in saline and humid environments. The satin finish enhances its formal purity, while the integration of foot wash, dual mixer, and concealed connections provides an intuitive and sophisticated user experience. A piece that harmonizes with gardens, spas, and contract spaces, bringing character and distinction.



COLLEZIONE

PALAU + DUO

OPZIONI DI COLORE
COLOR OPTIONS

*I prodotti della linea duo possono essere personalizzati su richiesta
** The products in the duo line can be customised on request.*

MADE IN ITALY
BREVETTO ITALIANO

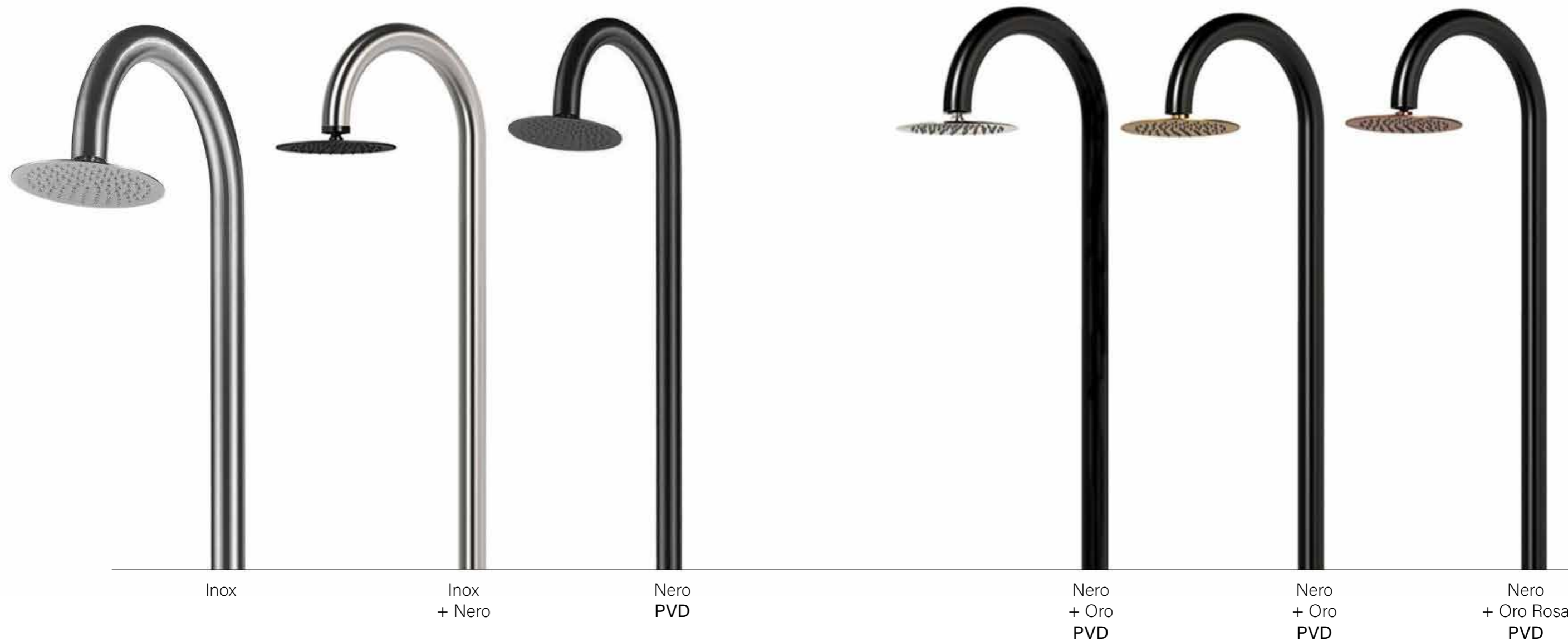

DOCCIA-PALAU-DUO

MADE IN ITALY 

STOCK

 **INOX-NERA** 8025431157774

 **NERA-INOX** 8025431157750

PVD  **NERA-ORO** 8025431157767 *

PVD  **NERA-ORO-ROSA** 8025431157774 *

*DISPONIBILE SOLO SU ORDINAZIONE

*AVAILABLE ONLY UPON REQUEST

CARATTERISTICHE

- **MATERIALE ACCIAIO INOX 316L / 316L STAINLESS STEEL**
- **UGELLI ANTICALCARE / ANTI LIMESCALE NOZZLES**
- **ACCESSORI IN ACCIAIO INOX 316L / STAINLESS STEEL 316L**
- **PESO/WEIGHT 16 KG**
- **PACKAGING 139X56X26 CM**
- **GETTO D'ACQUA / WATER JET VERTICALE**
- **INCLUDE SACCA DI PROTEZIONE/PROTECTION BAG**
- **ACQUA CALDA E FREDDA / WATER HOT AND COLD**



SISTEMA DI FISSAGGIO/FIXING SYSTEM C-BOX

*ULTERIORI INFORMAZIONI
*MORE INFORMATION PAG 283



SCANSIONA PER VEDERE IL VIDEO DEL MONTAGGIO
SCAN TO VIEW THE ASSEMBLY VIDEO

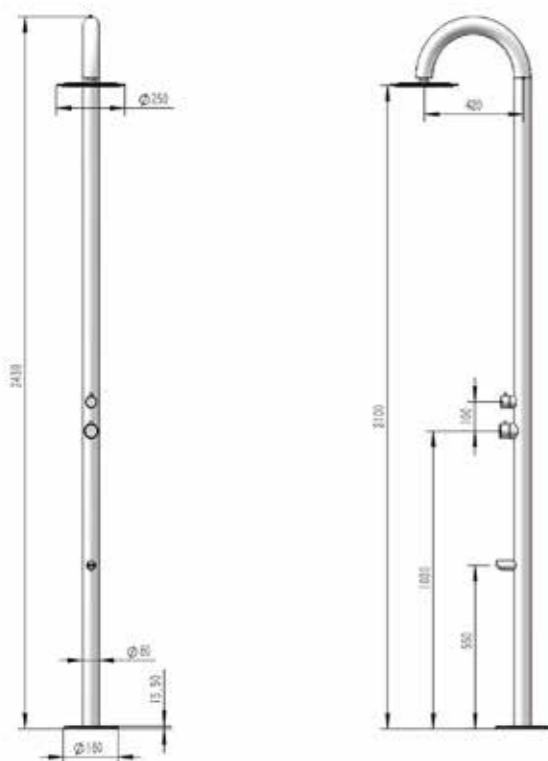
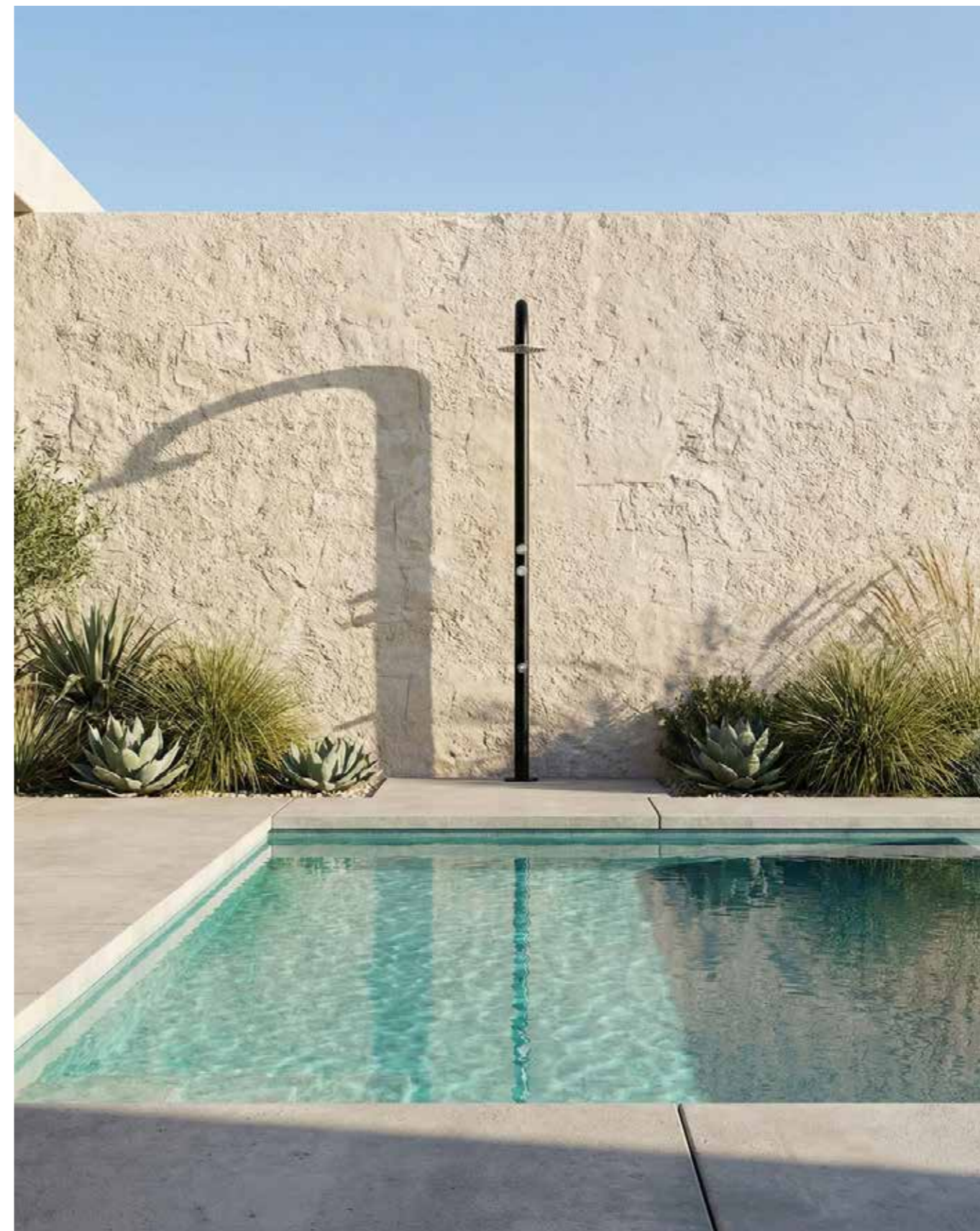

DOCCIA CHIA

Sofisticata scultura per ambienti outdoor

Con una forma essenziale e linee pulite, DOCCIA-CHIA unisce estetica contemporanea e ingegneria di precisione. Realizzata in acciaio inox AISI 316L, è ideale per ambienti marini e spazi esterni di pregio.

Le finiture in PVD oro, oro rosa e canna fucile aggiungono profondità materica e raffinatezza cromatica. Ogni elemento è pensato per durare e dialogare con l'architettura moderna. Più di una doccia: un segno di stile per l'outdoor.

Sculptural sophistication for outdoor environments

With a pure, linear form, DOCCIA-CHIA blends contemporary aesthetics with technical precision.

Crafted from marine-grade stainless steel AISI 316L, it is ideal for coastal environments and high-end outdoor spaces.

Finishes in PVD gold, rose gold, and gunmetal add material depth and chromatic elegance.

Every detail is designed to endure and harmonize with modern architecture.

More than a shower — a statement of outdoor design.



COLLEZIONE

CHIA

OPZIONI DI COLORE
COLOR OPTIONS

MADE IN ITALY
BREVETTO ITALIANO



White
Bianco

Brushed
Inox Spazzolato

Black
Nero
PVD

Gun Metal
Canna Fucile
PVD

Gold
Oro
PVD

Rose Gold
Oro Rosa
PVD

DOCCIA-CHIA

MADE IN ITALY 

STOCK

 INOX 8025431016712

PVD  CANNA-FUCILE 8025431153066

PVD  ORO-ROSA 8025431153073

PVD  NERA 8025431016729 *

PVD  ORO 8025431153042 *

 BIANCA 8025431153059 *

*DISPONIBILE SOLO SU ORDINAZIONE

*AVAILABLE ONLY UPON REQUEST

CARATTERISTICHE

- **MATERIALE ACCIAIO INOX 316L / 316L STAINLESS STEEL**
- **UGELLI ANTICALCARE / ANTI LIMESCALE NOZZLES**
- **ACCESSORI IN ACCIAIO INOX 316L / STAINLESS STEEL 316L**
- **PESO/WEIGHT 9,5 KG**
- **PACKAGING 139X56X26 CM**
- **GETTO D'ACQUA / WATER JET VERTICALE**
- **INCLUDE SACCA DI PROTEZIONE/PROTECTION BAG**
- **ACQUA CALDA E FREDDA / WATER HOT AND COLD**



SISTEMA DI FISSAGGIO/FIXING SYSTEM C-BOX

*ULTERIORI INFORMAZIONI
*MORE INFORMATION PAG 283



SCANSIONA PER VEDERE IL VIDEO DEL MONTAGGIO

SCAN TO VIEW THE ASSEMBLY VIDEO

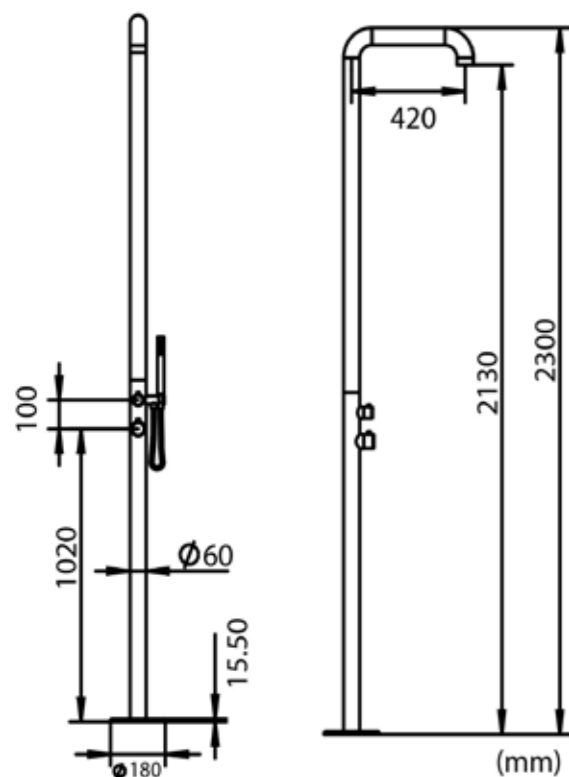

DOCCIA QUARTU

Design senza tempo, precisione funzionale

Con una geometria sobria e raffinata, DOCCIA-QUARTU ridefinisce l'esperienza della doccia outdoor con uno standard superiore di eleganza tecnica. La struttura in acciaio inox marino AISI 316L garantisce una durata impeccabile anche in contesti costieri difficili. Le finiture in PVD oro, oro rosa e canna fucile donano profondità materica e brillantezza sofisticata. Dotata di lavapiedi, doppio miscelatore e connessioni nascoste, rappresenta una soluzione completa ed esteticamente coerente. Un oggetto che si inserisce con naturalezza in giardini, spa o ambienti contract, donando carattere e distinzione.

Timeless design, functional precision

Defined by sober geometry and refined balance, DOCCIA-QUARTU reimagines the outdoor shower experience through the lens of technical elegance. Its body in marine-grade stainless steel AISI 316L ensures long-lasting performance, even in coastal or high-humidity environments.

PVD finishes in gold, rose gold and gunmetal enhance its surface with tactile depth and chromatic refinement. Equipped with foot wash, dual mixer, and concealed connections, it is a comprehensive solution of aesthetic and utility. An object that blends effortlessly into gardens, spas, and contract spaces, imparting identity and sophistication.



COLLEZIONE

QUARTU

OPZIONI DI COLORE
COLOR OPTIONS



White
Bianco

Brushed
Inox Spazzolato

Black
Nero
PVD

Gun Metal
Canna Fucile
PVD

Gold
Oro
PVD

Rose Gold
Oro Rosa
PVD

DOCCIA-QUARTU

STOCK

 **INOX** 8025431016835

PVD  **CANNA-FUCILE** 8025431019676

PVD  **ORO-ROSA** 8025431019690

PVD  **NERA** 8025431016743 *

PVD  **ORO** 8025431019683 *

 **BIANCA** 8025431152977 *

*DISPONIBILE SOLO SU ORDINAZIONE

*AVAILABLE ONLY UPON REQUEST

CARATTERISTICHE

- **MATERIALE ACCIAIO INOX 316L / 316L STAINLESS STEEL**
- **UGELLI ANTICALCARE / ANTI LIMESCALE NOZZLES**
- **ACCESSORI IN ACCIAIO INOX 316L / STAINLESS STEEL 316L**
- **PESO/WEIGHT 13,6 KG**
- **PACKAGING 129X56X26 CM**
- **GETTO D'ACQUA / WATER JET VERTICALE**
- **INCLUDE SACCA DI PROTEZIONE/PROTECTION BAG**
- **ACQUA CALDA E FREDDA / WATER HOT AND COLD**



FIXING SYSTEM C-BOX

*MORE INFORMATION PAG 283



SCANSIONA PER VEDERE IL VIDEO DEL
MONTAGGIO
SCAN TO VIEW THE **ASSEMBLY VIDEO**

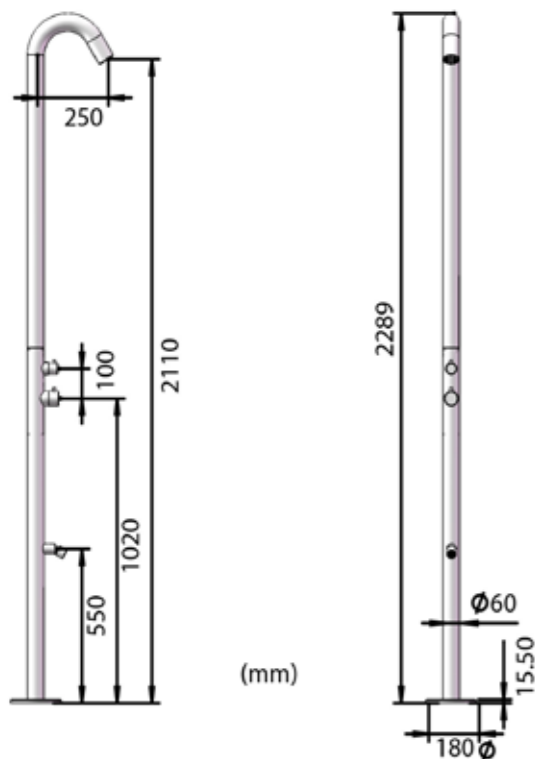

DOCCIA-QUARTU-DOPPIO-TMP

STOCK





 **INOX** 8025431157989

PVD  **CANNA-FUCILE** 8025431157972

PVD  **ORO-ROSA** 8025431158016



PVD  **NERA** 8025431157996 *

PVD  **ORO** 8025431158009 *

 **BIANCA** 8025431157965 *

*DISPONIBILE SOLO SU ORDINAZIONE
*AVAILABLE ONLY UPON REQUEST

CARATTERISTICHE

- **MATERIALE ACCIAIO INOX 316L / 316L STAINLESS STEEL**
- **UGELLI ANTICALCARE / ANTI LIMESCALE NOZZLES**
- **ACCESSORI IN ACCIAIO INOX 316L / STAINLESS STEEL 316L**
- **PESO/WEIGHT 13,6 KG**
- **PACKAGING 127X37X26 CM**
- **GETTO D'ACQUA / WATER JET VERTICALE**
- **INCLUDE SACCA DI PROTEZIONE/PROTECTION BAG**
- **PULSANTE TEMPORIZZATORE / TIMER FUNCTION** 
- **ACQUA FREDDA / WATER COLD** 

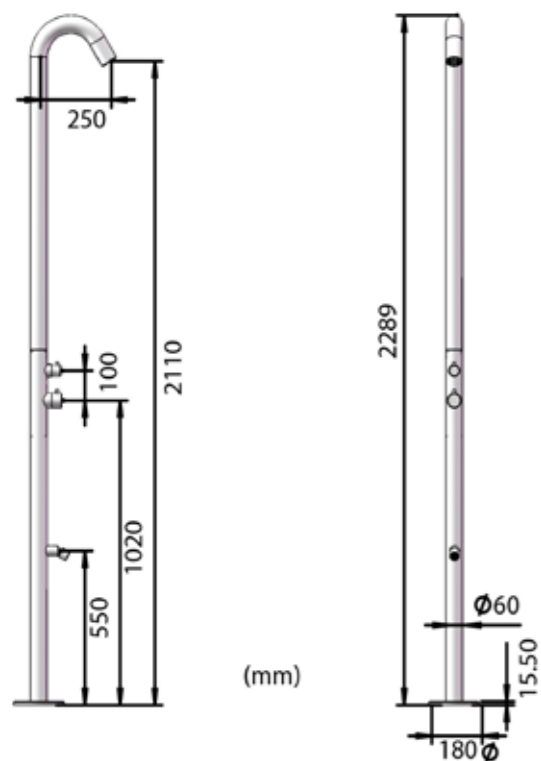

SISTEMA DI FISSAGGIO/FIXING SYSTEM C-BOX

*ULTERIORI INFORMAZIONI
*MORE INFORMATION PAG 283



SCANSIONA PER VEDERE IL VIDEO DEL
MONTAGGIO
SCAN TO VIEW THE **ASSEMBLY VIDEO**



DOCCIA OROSEI

Geometria essenziale, presenza architettonica

Un volume puro che definisce lo spazio con discrezione e carattere.

OROSEI nasce per integrarsi in contesti contemporanei, senza tempo.

Linee rigorose e proporzioni equilibrate danno forma a una doccia che è anche elemento d'arredo.

Una sintesi tra minimalismo formale e vocazione progettuale.

Perfetta per ambienti outdoor privati o professionali dove ogni dettaglio conta.

Essential geometry, architectural presence

A pure volume that defines space with both discretion and strength.

OROSEI is designed to blend into timeless, contemporary settings.

Its precise lines and balanced proportions shape a shower that becomes a true design feature.

A synthesis of formal minimalism and architectural intent.

Perfect for private or professional outdoor environments where every detail matters.



DOCCIA-OROSEI

STOCK





 **INOX** 8025431159228

PVD  **CANNA-FUCILE** 8025431159211

PVD  **ORO-ROSA** 8025431159259

PVD  **NERA** 8025431159235 *

PVD  **ORO** 8025431159242 *

 **BIANCA** 8025431159204 *

*DISPONIBILE SOLO SU ORDINAZIONE
*AVAILABLE ONLY UPON REQUEST

CARATTERISTICHE

- **MATERIALE ACCIAIO INOX 316L / 316L STAINLESS STEEL**
- **UGELLI ANTICALCARE / ANTI LIMESCALE NOZZLES**
- **ACCESSORI IN ACCIAIO INOX 316L / STAINLESS STEEL 316L**
- **PESO/WEIGHT** 13,6 KG
- **PACKAGING** 127X37X26 CM
- **GETTO D'ACQUA / WATER JET** VERTICALE
- **INCLUDE SACCA DI PROTEZIONE/PROTECTION BAG**
- **SPECIALE SOFFIONE CILINDRICO / SPECIAL CYLINDRICAL SHOWER HEAD**
- **ACQUA CALDA E FREDDA / WATER HOT AND COLD**

SISTEMA DI FISSAGGIO/FIXING SYSTEM C-BOX

*ULTERIORI INFORMAZIONI
*MORE INFORMATION PAG 283

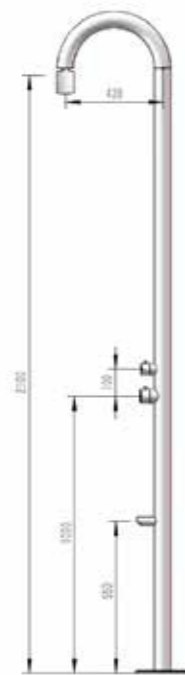

SCANSIONA PER VEDERE IL VIDEO DEL
MONTAGGIO
SCAN TO VIEW THE **ASSEMBLY VIDEO**



DOCCIA ALGHERO

Design essenziale, carattere duraturo

Con una silhouette curva e linee essenziali, DOCCIA-ALGHERO rappresenta la sintesi perfetta tra funzionalità ed estetica contemporanea. Realizzata in acciaio inox marino AISI 316L, offre una resistenza superiore in ambienti salini e umidi. La finitura satinata esalta la purezza delle sue linee, mentre l'integrazione di doccetta, doppio miscelatore e connessioni nascoste garantisce un'esperienza d'uso intuitiva e sofisticata. Un elemento che si inserisce armoniosamente in giardini, spa e spazi contract, apportando carattere e distinzione.

Essential design, enduring character

With a curved and refined silhouette, DOCCIA-ALGHERO embodies the perfect synthesis of functionality and contemporary aesthetics. Crafted from marine-grade stainless steel AISI 316L, it offers superior resistance in saline and humid environments. Its satin finish enhances the purity of its lines, while the integration of a hand shower, dual mixer, and concealed connections ensures an intuitive and sophisticated user experience. A piece that harmoniously integrates into gardens, spas, and contract spaces, bringing character and distinction.



DOCCIA-ALGHERO

STOCK

 INOX 8025431016668

PVD  NERA 8025431016675



CARATTERISTICHE

- **MATERIALE ACCIAIO INOX 316L / 316L STAINLESS STEEL**
- **UGELLI ANTICALCARE / ANTI LIMESCALE NOZZLES**
- **ACCESSORI IN ACCIAIO INOX 316L / STAINLESS STEEL 316L**
- **PESO/WEIGHT 12,6 KG**
- **PACKAGING 127X37X26 CM**
- **GETTO D'ACQUA / WATER JET DIAGONAL**
- **INCLUDE SACCA DI PROTEZIONE/PROTECTION BAG**
- **ACQUA CALDA E FREDDA / WATER HOT AND COLD**



SISTEMA DI FISSAGGIO/FIXING SYSTEM C-BOX

*ULTERIORI INFORMAZIONI
*MORE INFORMATION PAG 283



SCANSIONA PER VEDERE IL VIDEO DEL
MONTAGGIO
SCAN TO VIEW THE **ASSEMBLY VIDEO**

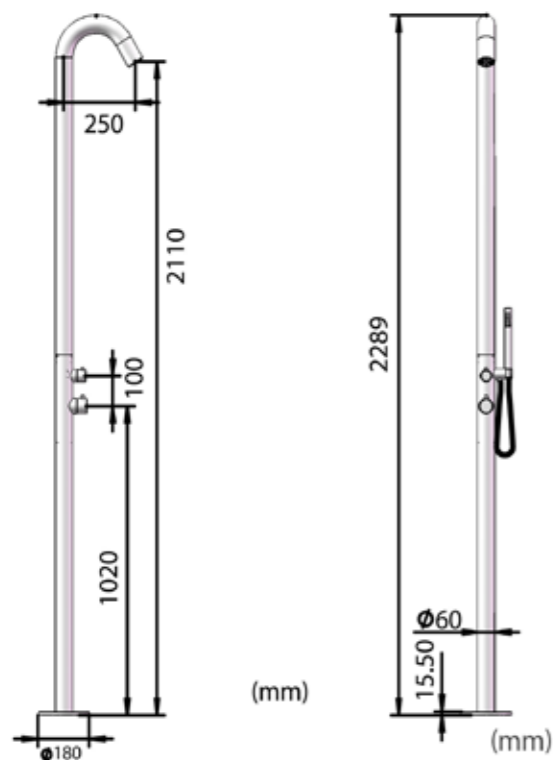

DOCCIA BOSA

Essenzialità e presenza per l'outdoor contemporaneo

Realizzata in acciaio inox AISI 316L, combina resistenza e durabilità con un'estetica pulita e senza tempo.

Progettata per ambienti esterni come giardini, terrazze e aree piscina, si integra con discrezione in ogni contesto architettonico.

La sua sagoma lineare enfatizza lo spazio, trasformando un elemento funzionale in un dettaglio di design.

Una soluzione outdoor che unisce performance e stile, pensata per durare nel tempo.

Essentiality and presence for contemporary outdoor spaces

Made of AISI 316L stainless steel, it combines strength and durability with a clean, timeless aesthetic.

Designed for outdoor environments such as gardens, terraces and pool areas, it blends discreetly into any architectural context.

Its linear shape emphasises the space, transforming a functional element into a design detail.

An outdoor solution that combines performance and style, designed to last over time.



DOCCIA-BOSA



STOCK

 **INOX** 8025431016682

PVD  **NERA** 8025431016699

CARATTERISTICHE

- **MATERIALE ACCIAIO INOX 316L / 316L STAINLESS STEEL**
- **UGELLI ANTICALCARE / ANTI LIMESCALE NOZZLES**
- **ACCESSORI IN ACCIAIO INOX 316L / STAINLESS STEEL 316L**
- **PESO/WEIGHT 14 KG**
- **PACKAGING 127X37X26 CM**
- **GETTO D'ACQUA / WATER JET DIAGONAL**
- **INCLUDE SACCA DI PROTEZIONE/PROTECTION BAG**
- **DOCCINO FLESSIBILE E LAVAPIEDI/FLEXIBLE SHOWER HEAD AND FOOT WASH**
- **ACQUA CALDA E FREDDA / WATER HOT AND COLD**

SISTEMA DI FISSAGGIO/FIXING SYSTEM C-BOX

*ULTERIORI INFORMAZIONI
*MORE INFORMATION PAG 283



SCANSIONA PER VEDERE IL VIDEO DEL
MONTAGGIO
SCAN TO VIEW THE **ASSEMBLY VIDEO**

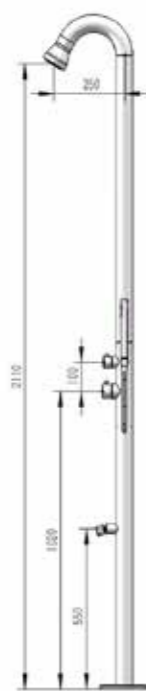
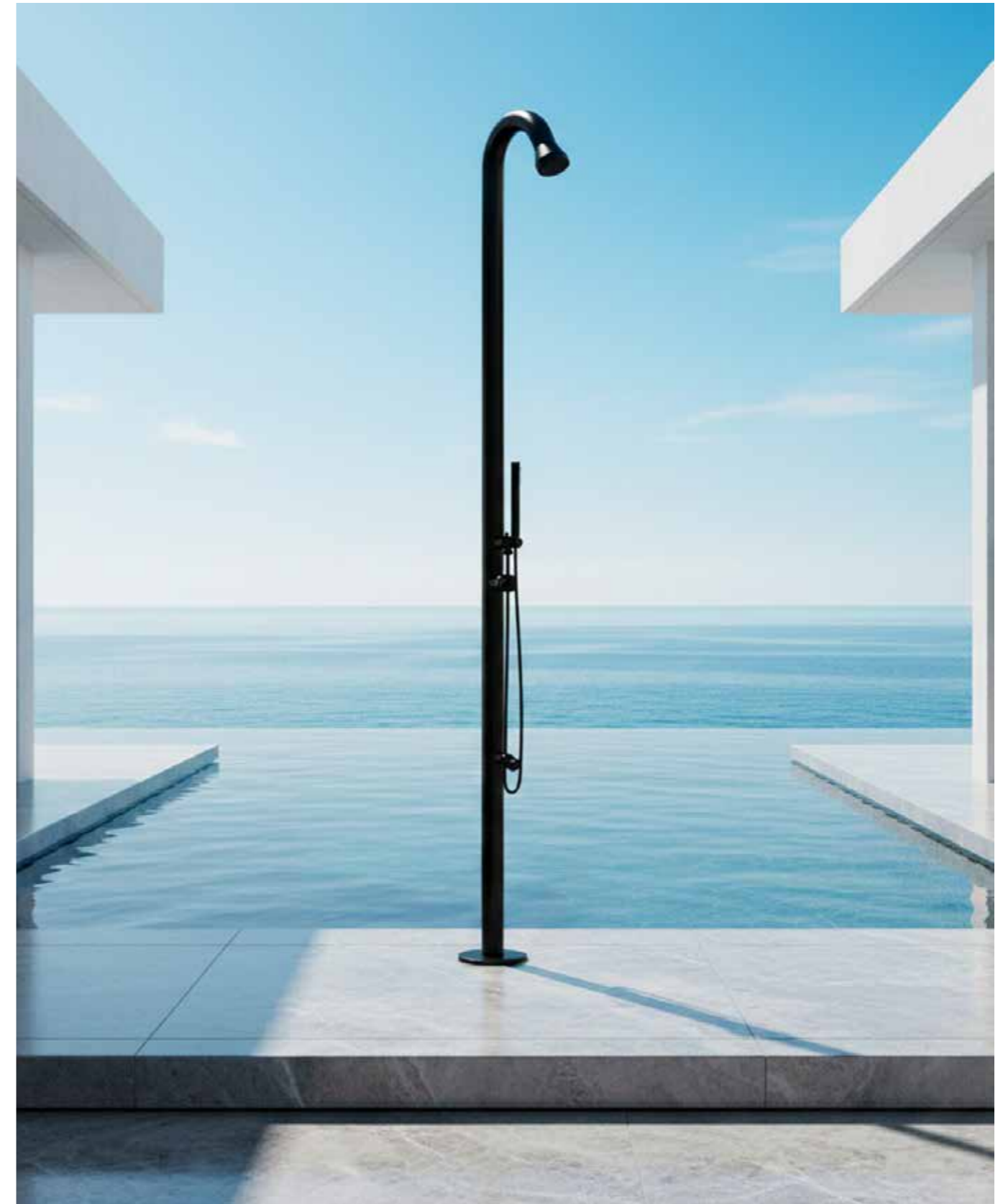

DOCCIA OLBIA

Design imponente, resistenza senza compromessi

DOCCIA-OLBIA si presenta come una scultura funzionale dalle linee pulite e presenza architettonica. Il suo corpo in acciaio inox AISI 316L con finitura satinata garantisce una resistenza eccezionale in ambienti marini e urbani. Dotata di miscelatore integrato, lavapiedi e sistema di fissaggio C-BOX, offre un'installazione sicura e un'estetica impeccabile. Ideale per giardini, piscine e spazi contract che cercano un pezzo di design duraturo e sofisticato.

Imposing design, uncompromising durability

DOCCIA-OLBIA stands as a functional sculpture with clean lines and architectural presence. Its body in AISI 316L stainless steel with a satin finish ensures exceptional resistance in marine and urban environments. Equipped with integrated mixer, foot wash, and C-BOX fixing system, it offers secure installation and impeccable aesthetics. Ideal for gardens, pools, and contract spaces seeking a durable and sophisticated design piece.



DOCCIA-OLBIA



STOCK

 INOX 8025431152984

PVD  NERA 8025431152991

CARATTERISTICHE

- **MATERIALE ACCIAIO INOX 316L / 316L STAINLESS STEEL**
- **UGELLI ANTICALCARE / ANTI LIMESCALE NOZZLES**
- **ACCESSORI IN ACCIAIO INOX 316L / STAINLESS STEEL 316L**
- **PESO/WEIGHT 16 KG**
- **PACKAGING 127X37X26 CM**
- **GETTO D'ACQUA / WATER JET VERTICALE**
- **INCLUDE SACCA DI PROTEZIONE/PROTECTION BAG**
- **ACQUA CALDA E FREDDA / WATER HOT AND COLD**

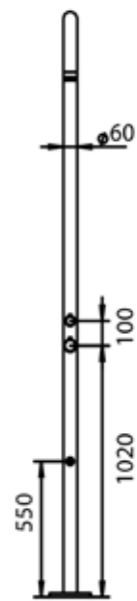
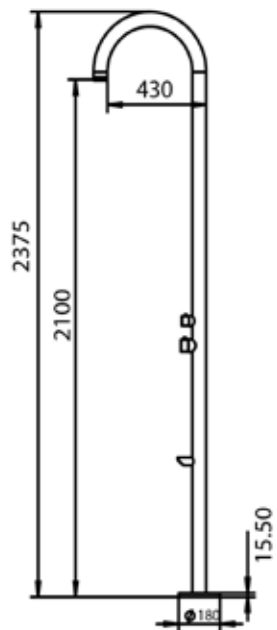

(mm)

SISTEMA DI FISSAGGIO/FIXING SYSTEM C-BOX

*ULTERIORI INFORMAZIONI
*MORE INFORMATION PAG 283



SCANSIONA PER VEDERE IL VIDEO DEL MONTAGGIO
SCAN TO VIEW THE **ASSEMBLY VIDEO**



DOCCIA BUDONI

Versatilità contemporanea, precisione tecnica

DOCCIA-BUDONI fonde funzionalità e design con un'estetica sobria e raffinata. Realizzata in acciaio inox AISI 316L, offre resistenza superiore in ambienti salini e umidi. La finitura satinata esalta la purezza formale, mentre l'integrazione di doccetta, doppio miscelatore e connessioni nascoste fornisce un'esperienza d'uso intuitiva e sofisticata. Un elemento che si adatta armoniosamente a giardini, spa e spazi contract, apportando carattere e distinzione.

Contemporary versatility, technical precision

DOCCIA-BUDONI merges functionality and design with a sober and refined aesthetic. Crafted from AISI 316L stainless steel, it offers superior resistance in saline and humid environments. The satin finish enhances its formal purity, while the integration of hand shower, dual mixer, and concealed connections provides an intuitive and sophisticated user experience. A piece that adapts seamlessly to gardens, spas, and contract spaces, adding character and distinction.



DOCCIA-BUDONI



STOCK

 INOX 8025431016705

PVD  NERA 8025431016798

CARATTERISTICHE

- **MATERIALE ACCIAIO INOX 316L / 316L STAINLESS STEEL**
- **UGELLI ANTICALCARE / ANTI LIMESCALE NOZZLES**
- **ACCESSORI IN ACCIAIO INOX 316L / STAINLESS STEEL 316L**
- **PESO/WEIGHT 10,3 KG**
- **PACKAGING 135X62X26 CM**
- **GETTO D'ACQUA / WATER JET VERTICALE**
- **DOPPIO PULSANTE PER SCEGLIERE FRA SOFFIONE E DOCGETTA**
DUAL DOUBLE BUTTON TO CHOOSE BETWEEN SHOWER HEAD AND DUAL HAND SHOWER
- **INCLUDE SACCA DI PROTEZIONE/PROTECTION BAG**
- **ACQUA CALDA E FREDDA / WATER HOT AND COLD**

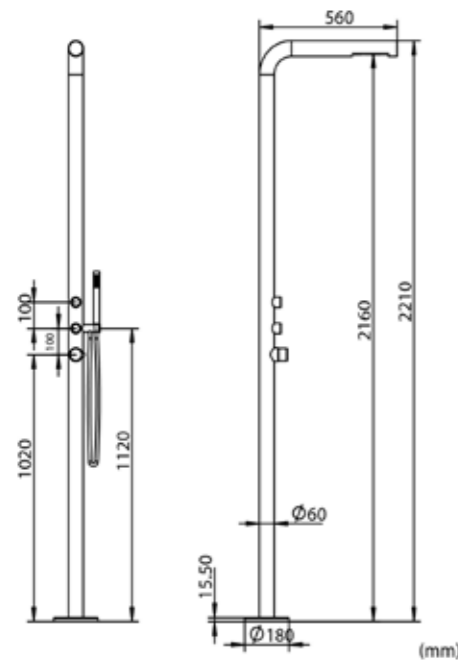

SISTEMA DI FISSAGGIO/FIXING SYSTEM C-BOX

*ULTERIORI INFORMAZIONI
*MORE INFORMATION PAG 283



SCANSIONA PER VEDERE IL VIDEO DEL MONTAGGIO
SCAN TO VIEW THE ASSEMBLY VIDEO



DOCCIA STINTINO

Eleganza all'aperto, resistenza all'infinito

Linee pure per ambienti esterni, con sguardo deciso verso l'orizzonte.
STINTINO reinterpreta la doccia da giardino con rigore tecnico e presenza essenziale.
In acciaio inox marino AISI 316L, garantisce durabilità anche in condizioni estreme.
Include soffione orientabile, lavapiedi e doccino, con attacchi a scomparsa.
Una soluzione elegante per piscine, giardini, spa e architetture outdoor.

Outdoor elegance, unlimited resilience

Pure lines for exterior settings, with a bold gaze toward the horizon.
STINTINO reimagines the garden shower with technical precision and essential presence.
Crafted in marine-grade AISI 316L stainless steel, it delivers lasting durability even in harsh environments.
Features an adjustable shower head, foot rinse and hand shower, with hidden connections.
An elegant solution for pools, gardens, spas and architectural landscapes outdoors.



DOCCIA-STINTINO

STOCK

 **INOX** 8025431016774

PVD  **NERA** 8025431016842

CARATTERISTICHE

- **MATERIALE ACCIAIO INOX 316L / 316L STAINLESS STEEL**
- **UGELLI ANTICALCARE / ANTI LIMESCALE NOZZLES**
- **ACCESSORI IN ACCIAIO INOX 316L / STAINLESS STEEL 316L**
- **PESO/WEIGHT 13,6 KG**
- **PACKAGING 127X37X26 CM**
- **GETTO D'ACQUA / WATER JET VERTICALE**
- **SOFFIONE DIREZIONALE / DIRECTIONAL SHOWER HEAD**
- **MODELLO SPECIALE CON DOCCIA FLESSIBILE E LAVAPIEDI**
MODEL WITH SHOWER HEAD AND FOOT WASH
- **INCLUDE SACCA DI PROTEZIONE/PROTECTION BAG**
- **ACQUA CALDA E FREDDA / WATER HOT AND COLD**



SISTEMA DI FISSAGGIO/FIXING SYSTEM C-BOX

*ULTERIORI INFORMAZIONI
*MORE INFORMATION PAG 283



SCANSIONA PER VEDERE IL VIDEO DEL
MONTAGGIO
SCAN TO VIEW THE **ASSEMBLY VIDEO**



DOCCIA SASSARI

Eleganza marina incontrata alla funzione esterna

Linee pure pensate per esterni, raffinate nel contesto di piscine e giardini.
SASSARI reinterpreta il concetto di doccia da esterno con rigore tecnico ed essenzialità.
Costruita in acciaio inox marino AISI 316L, resiste al tempo e all'ambiente salino.
Incorpora miscelatore, soffione orientabile e doccetta con attacchi nascosti.
Una presenza architettonica che arricchisce spazi wellness e design outdoor.

Marine elegance tailored for the outdoors

Pure lines conceived for outdoor spaces, ideal for gardens and pools.
SASSARI redefines the outdoor shower with technical precision and minimal essence.
Crafted in marine-grade AISI 316L stainless steel, it endures time and saline exposure gracefully.
Equipped with a mixer, adjustable showerhead and hand shower with concealed connections.
An architectural presence that enriches wellness areas and outdoor design settings.



DOCCIA-SASSARI

STOCK

INOX 8025431016750

CARATTERISTICHE

- **MATERIALE ACCIAIO INOX 316L / 316L STAINLESS STEEL**
- **UGELLI ANTICALCARE / ANTI LIMESCALE NOZZLES**
- **ACCESSORI IN ACCIAIO INOX 316L / STAINLESS STEEL 316L**
- **PESO/WEIGHT 9,3 KG**
- **PACKAGING 129X56X27 CM**
- **GETTO D'ACQUA / WATER JET VERTICALE**
- **INCLUDE SACCA DI PROTEZIONE/PROTECTION BAG**
- **LAMINARE CON AERATORE ANTISCHIZZO LAMINATE WITH SPLASH GUARD AERATOR**
- **ACQUA CALDA E FREDDA / WATER HOT AND COLD**



SISTEMA DI FISSAGGIO/FIXING SYSTEM C-BOX

*ULTERIORI INFORMAZIONI
*MORE INFORMATION PAG 283



SCANSIONA PER VEDERE IL VIDEO DEL MONTAGGIO
SCAN TO VIEW THE ASSEMBLY VIDEO

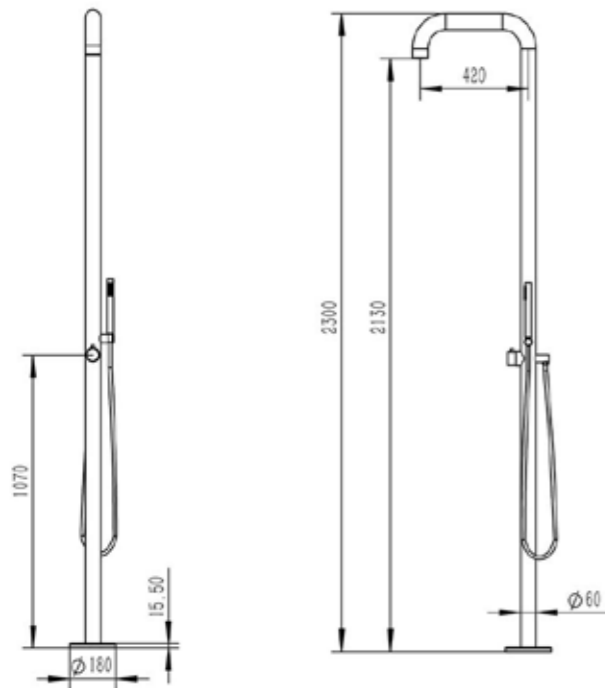

DOCCE IN ACCIAIO INOX NAUTICO 316L ACQUA FREDDA O PREMISCELATA

316L MARINE GRADE STAINLESS STEEL SHOWERS SPECIALLY DESIGNED FOR COLD OR PRE-MIXED WATER



Docce in Acciaio Inox 316L – Solo Acqua Fredda o Premiscelata

La gamma di docce SINED in acciaio inox marino AISI 316L, dedicate all'uso con acqua fredda o premiscelata, rappresenta la linea più essenziale e accessibile dell'offerta outdoor.

Una collezione pensata per chi cerca funzionalità e resistenza, senza rinunciare allo stile e alla qualità che da sempre contraddistinguono il marchio.

Rispetto alle gamme dotate di miscelatori termostatici o funzioni avanzate, questa linea si distingue per una configurazione tecnica più semplice, ideale per contesti residenziali, giardini privati, terrazze o impianti con uso continuo.

Realizzate in acciaio inox AISI 316L – lo stesso impiegato in ambienti marini – queste docce garantiscono una lunga durata e una straordinaria resistenza alla corrosione e agli agenti atmosferici.

L'estetica è pulita, essenziale, con superfici satiniate che valorizzano ambienti contemporanei e architetture all'aperto.

Tra i modelli principali, Nora e Teulada rispondono perfettamente alle esigenze di installazione rapida e uso quotidiano in ambienti privati o pubblici.

Il modello Santadi introduce una caratteristica in più: è predisposto per sistema a gettone, rendendolo la scelta ideale per spiagge, campeggi, piscine pubbliche e impianti sportivi.

In Italia, dove l'utilizzo delle docce a pagamento è una consuetudine diffusa, Santadi diventa un alleato efficiente e affidabile.

Questa gamma incarna lo spirito SINED: materiali nobili, funzionalità concrete, estetica minimale e un prezzo competitivo. Perfetta per chi desidera qualità e durata senza eccessi.

316L Stainless Steel Showers – Cold or Pre-Mixed Water

The SINED range of cold or pre-mixed water showers in marine-grade AISI 316L stainless steel represents the brand's most accessible and streamlined outdoor collection.

Designed for those who value simplicity, durability and clean aesthetics, these models offer the essentials – without compromising on material excellence or visual elegance.

Unlike more advanced product lines that feature thermostatic mixers or multiple functions, this range takes a more minimal, functional approach. It is ideal for residential gardens, private terraces, or high-traffic facilities where ease of use and reliability are key.

Built entirely from 316L stainless steel – known for its corrosion resistance and marine durability – these showers are designed to last in demanding environments, including coastal or sun-exposed locations. Their satin finish and minimalist silhouette integrate easily into contemporary architecture.

Among the highlights, Nora and Teulada provide simple, refined solutions for everyday outdoor use.

The Santadi model offers an added benefit: it is coin-system ready, making it ideal for beaches, campsites, public pools and sports centres.

In countries like Italy, where paid outdoor showers are commonly used, Santadi offers an efficient, durable response to public-use demands.

This collection is the perfect entry point to the SINED universe – premium materials, elegant form and practical performance at a more accessible price. For those who want smart design without unnecessary complexity.

DOCCIA NORA

Solo Acqua fredda o premiscelata con rubinetto doppia possibilità di collegamento inferiore o laterale 1/2"

Una presenza di design, pensata per l'esterno

Doccia da esterno in acciaio inox 316L, perfetta per acqua fredda o premiscelata. Rubinetto a leva semplice e intuitivo, con doppia opzione di collegamento: laterale o inferiore 1/2". Ideale per giardini, spiagge, piscine e spazi condivisi dove funzionalità e resistenza fanno la differenza. Funzionale e duratura, mantiene il suo carattere elegante nel tempo.

A design presence crafted for the outdoors

Outdoor shower in 316L stainless steel, perfect for cold or premixed water. Simple and intuitive lever tap with two connection options: side or bottom 1/2". Ideal for gardens, beaches, swimming pools and shared spaces where functionality and durability make the difference. Functional and durable, it retains its elegant character over time.

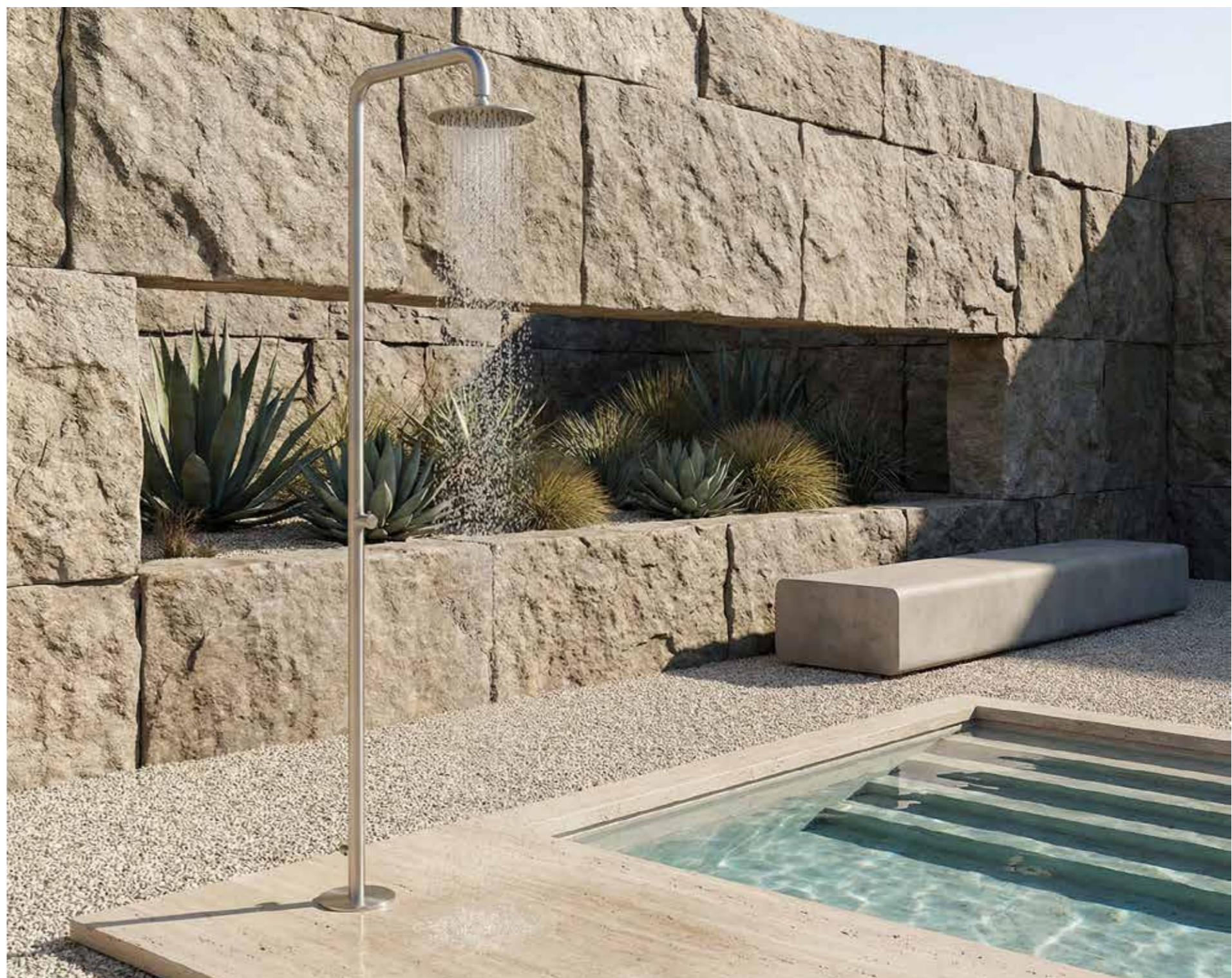

DOCCIA-NORA

STOCK



 **INOX** 8025431158474

PVD  **CANNA-FUCILE** 8025431158573

PVD  **ORO-ROSA** 8025431158566

PVD  **ORO** 8025431158559 *

*DISPONIBILE SOLO SU ORDINAZIONE

*AVAILABLE ONLY UPON REQUEST

CARATTERISTICHE

- **MATERIALE ACCIAIO INOX 316L / 316L STAINLESS STEEL**
- **UGELLI ANTICALCARE / ANTI LIMESCALE NOZZLES**
- **ACCESSORI IN ACCIAIO INOX 316L / STAINLESS STEEL 316L**
- **PESO/WEIGHT 14 KG**
- **PACKAGING 127X37X26 CM**
- **GETTO D'ACQUA / WATER JET VERTICALE**
- **INCLUDE SACCA DI PROTEZIONE/PROTECTION BAG**
- **SOFFIONE IN ACCIAIO/STEEL SHOWER HEAD Ø25CM**
- **MANIGLIA APRI E CHIUDI / TURN HANDLE**
- **LATO CONNESSIONI E SOTTO L'INGRESSO DELL'ACQUA / CONNECTIONS SIDE AND BELOW WATER INLET 1/2**
- **ACQUA FREDDA OR PREMISCELATA / WATER COLD OR PREMIXED**

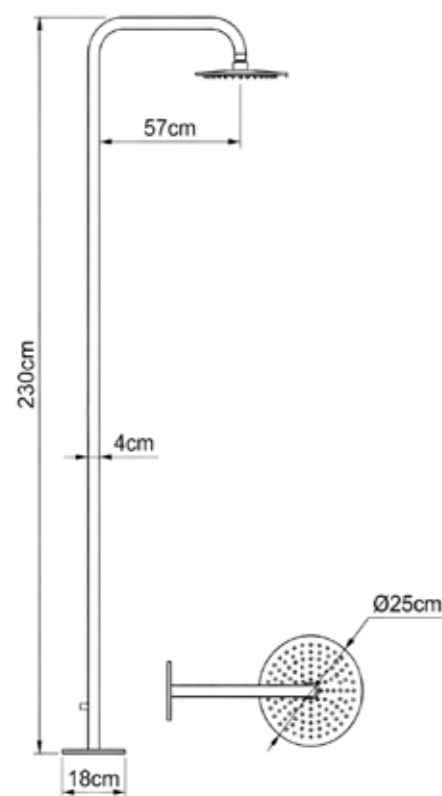

SISTEMA DI FISSAGGIO / FIXING SYSTEM
DOPPIO COLLEGAMENTO / DOUBLE CONNECTION

4 VITI / SCREWS

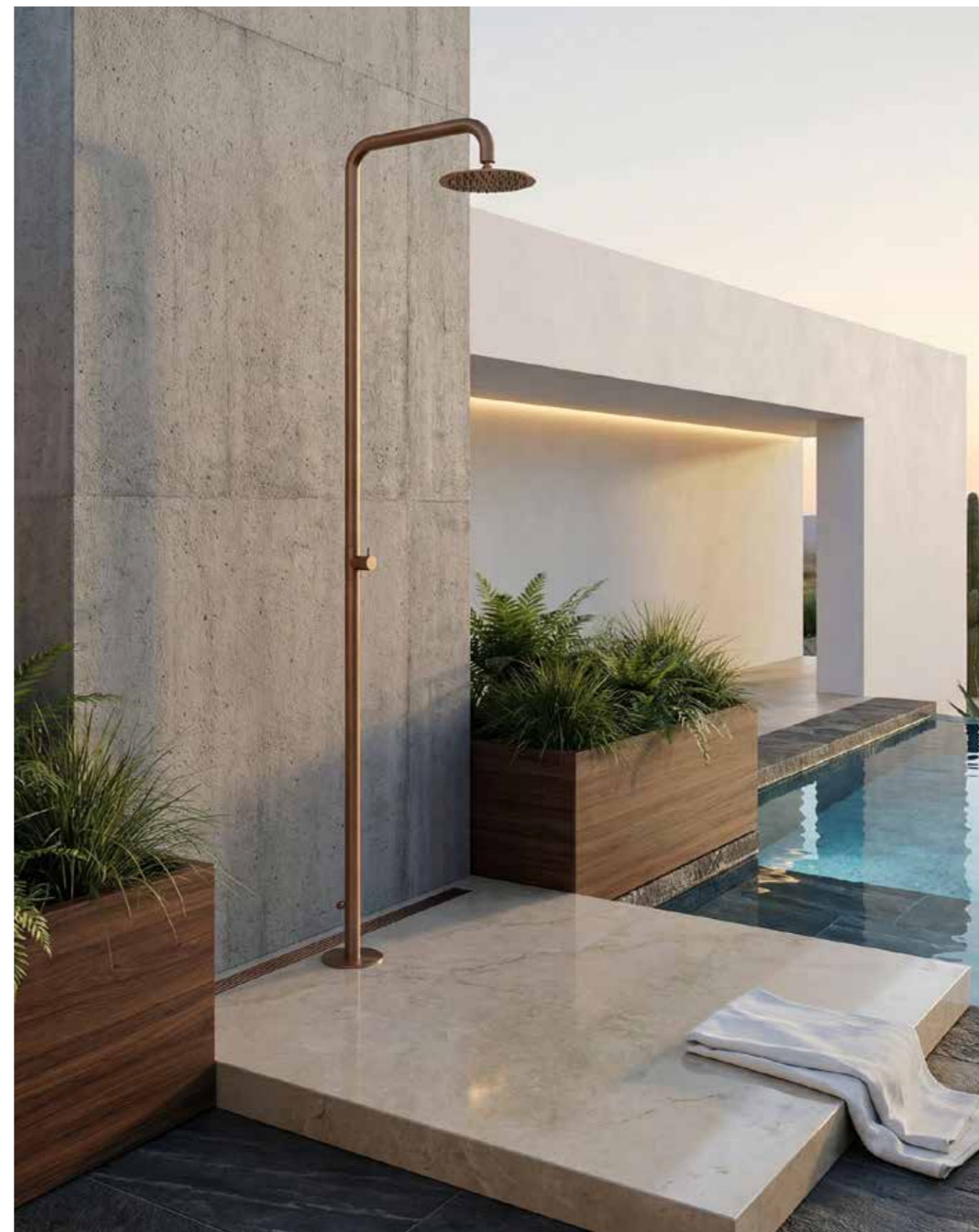

DOCCIA TEULADA

Solo Acqua fredda o premiscelata con lavapiedi, 2 pulsanti temporizzati: uno per il soffione e uno per il lavapiedi e doppia possibilità di collegamento inferiore o laterale ½ "

Equilibrio tra materia, funzione e paesaggio

Doccia da esterno in acciaio inox 316L per sola acqua fredda o premiscelata, dotata di lavapiedi integrato.

I due pulsanti temporizzati garantiscono un utilizzo controllato e responsabile dell'acqua. Doppia possibilità di collegamento, inferiore o laterale ½", per un'installazione flessibile in ogni contesto.

Ideale per giardini, piscine e spazi comuni dove comfort e praticità si incontrano.

Balance between material, function and landscape

Outdoor shower in 316L stainless steel for cold or premixed water only, equipped with integrated foot wash.

The two timed buttons ensure controlled and responsible use of water.

Dual connection option, bottom or side ½", for flexible installation in any context.

Ideal for gardens, swimming pools and common areas where comfort and practicality meet.



DOCCIA-TEULADA

STOCK



 **INOX** 8025431158580

PVD  **CANNA-FUCILE** 8025431158610

PVD  **ORO-ROSA** 8025431158603

PVD  **ORO** 8025431158597*

*DISPONIBILE SOLO SU ORDINAZIONE

*AVAILABLE ONLY UPON REQUEST

CARATTERISTICHE

- **MATERIALE ACCIAIO INOX 316L / 316L STAINLESS STEEL**
- **UGELLI ANTICALCARE / ANTI LIMESCALE NOZZLES**
- **ACCESSORI IN ACCIAIO INOX 316L / STAINLESS STEEL 316L**
- **PESO/WEIGHT 14 KG**
- **PACKAGING 127X37X26 CM**
- **GETTO D'ACQUA / WATER JET VERTICALE**
- **INCLUDE SACCA DI PROTEZIONE/PROTECTION BAG**
- **SOFFIONE IN ACCIAIO / STEEL SHOWER HEAD Ø25CM**
- **DOPPIO PULSANTE TEMPORIZZATORE SEPARATO PER SOFFIONE E LAVAPIEDI
SEPARATE DUAL-BUTTON TIMER FOR SHOWER HEAD AND FOOT WASH**
- **LATO CONNESSIONI E SOTTO L'INGRESSO DELL'ACQUA / CONNECTIONS SIDE AND BELOW WATER INLET 1/2**
- **ACQUA FREDDA OR PREMISCELATA / WATER COLD OR PREMIXED**

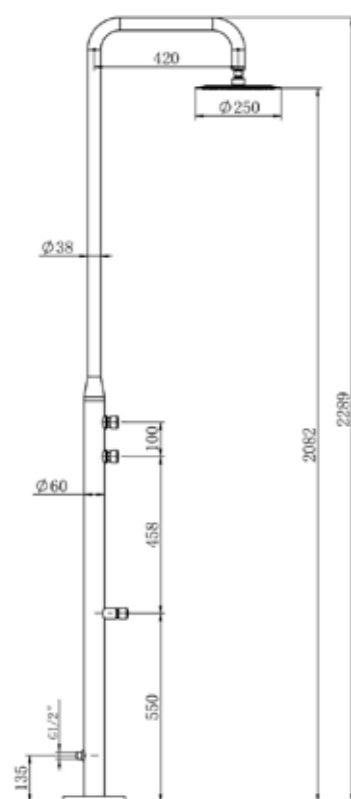

SISTEMA DI FISSAGGIO / FIXING SYSTEM
DOPPIO COLLEGAMENTO / DOUBLE CONNECTION

4 VITI / SCREWS

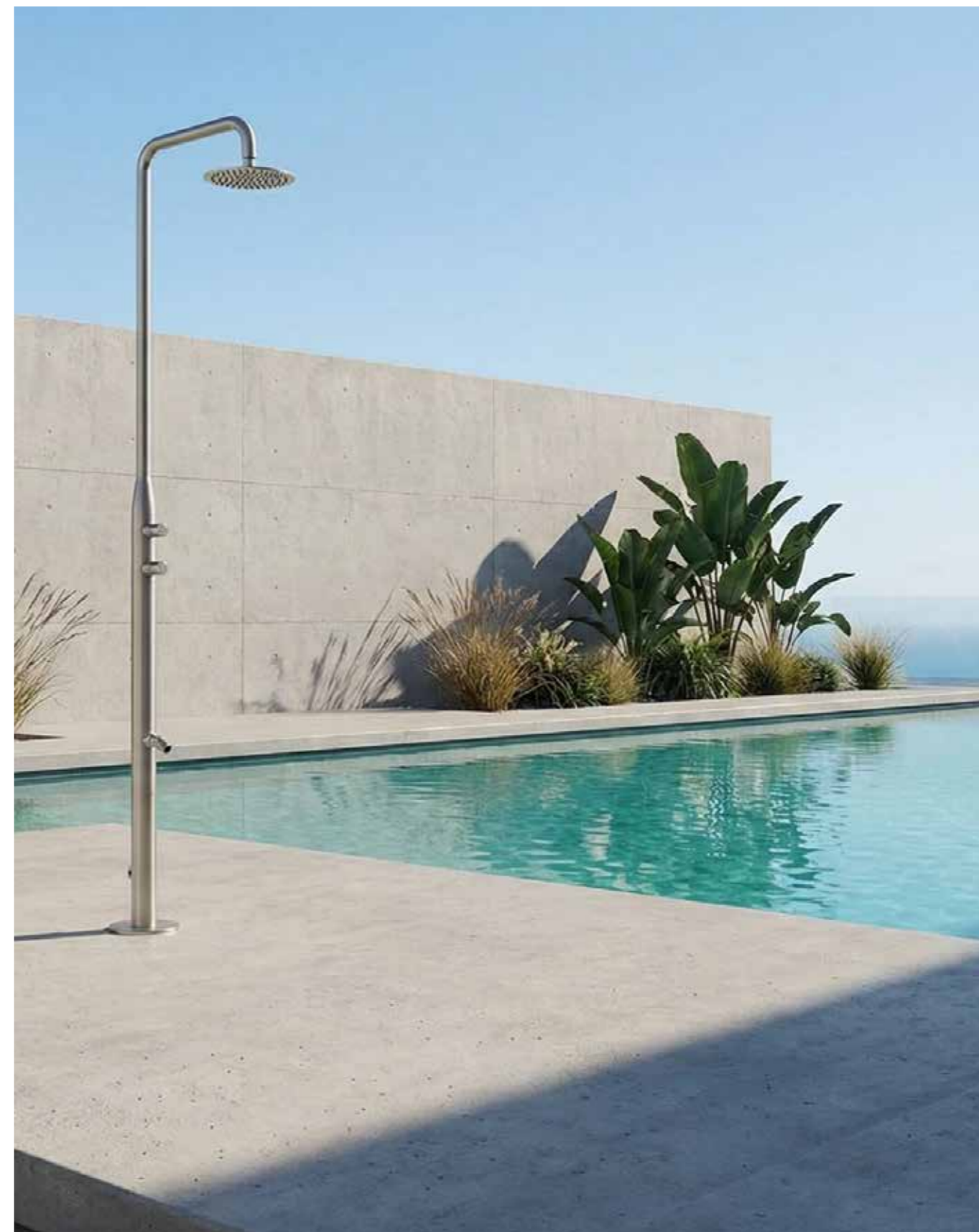

DOCCIA SANTADI

**Solo Acqua fredda o premiscelata senza rubinetti per installazione con gettoniere ed elettrovalvole.
Doppia possibilità di collegamento inferiore o laterale 1/2 "**

Progettata per l'uso pubblico e ad alta frequenza.

Doccia da esterno in acciaio inox 316L per sola acqua fredda o premiscelata, predisposta per installazione con gettoniera ed elettrovalvole, senza rubinetti.

Ideale per spiagge, stabilimenti balneari e aree pubbliche dove il controllo dei consumi è essenziale.

Doppia possibilità di collegamento, inferiore o laterale 1/2", per una massima flessibilità di installazione.

Una soluzione robusta, affidabile e pensata per durare nel tempo anche in ambienti marini.

Designed for public and high-frequency use.

Outdoor shower in 316L stainless steel for cold or premixed water only, designed for installation with coin mechanism and solenoid valves, without taps.

Ideal for beaches, bathing establishments and public areas where consumption control is essential.

Dual connection option, bottom or side 1/2", for maximum installation flexibility.

A robust, reliable solution designed to last over time, even in marine environments.



DOCCIA-SANTADI

STOCK

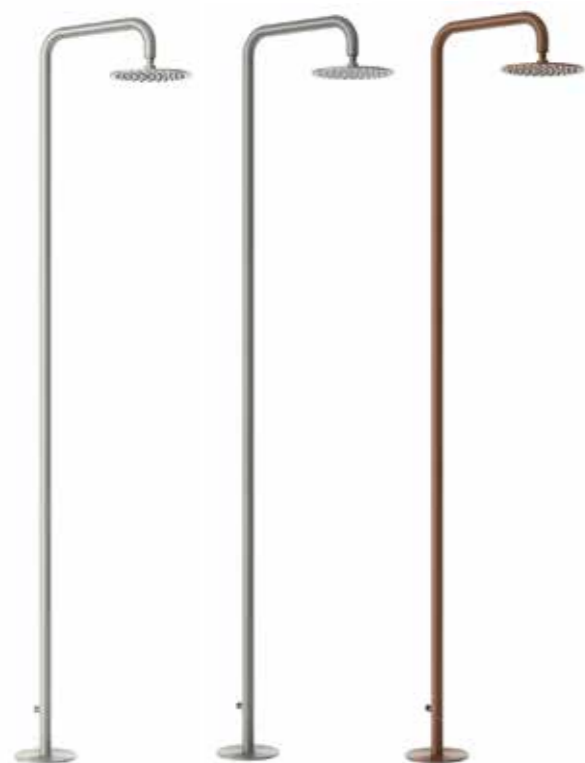

 **INOX** 8025431158627

PVD  **CANNA-FUCILE** 8025431158658

PVD  **ORO-ROSA** 8025431158641

PVD  **ORO** 8025431158634 *

*DISPONIBILE SOLO SU ORDINAZIONE

*AVAILABLE ONLY UPON REQUEST

CARATTERISTICHE

- **MATERIALE ACCIAIO INOX 316L / 316L STAINLESS STEEL**
- **UGELLI ANTICALCARE / ANTI LIMESCALE NOZZLES**
- **ACCESSORI IN ACCIAIO INOX 316L / STAINLESS STEEL 316L**
- **PESO/WEIGHT 14 KG**
- **PACKAGING 127X37X26 CM**
- **GETTO D'ACQUA / WATER JET VERTICALE**
- **INCLUDE SACCA DI PROTEZIONE/PROTECTION BAG**
- **SOFFIONE IN ACCIAIO/STEEL SHOWER HEAD Ø25CM**
- **SPECIFICA PER GETTONIERE O ELETTROVALVOLE SPECIFIC FOR COIN MECHANISMS OR SOLENOID VALVES**
- **NESSUN RUBINETTO O MISCELATORE / NO TAP OR MIXER**
- **LATO CONNESSIONI E SOTTO L'INGRESSO DELL'ACQUA / CONNECTIONS SIDE AND BELOW WATER INLET 1/2**
- **ACQUA FREDDA OR PREMISCELATA / WATER COLD OR PREMIXED** 

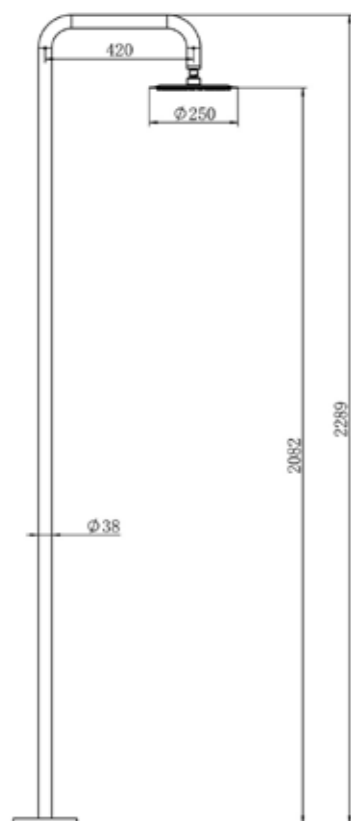

SISTEMA DI FISSAGGIO / FIXING SYSTEM
DOPPIO COLLEGAMENTO / DOUBLE CONNECTION

4 VITI / SCREWS



DOCCIA SIMIUS

Solo Acqua fredda, trasportabile con piantana antiribaltamento e collegamento laterale ½ "

Semplicità formale, essenza contemporanea

DOCCIA-SIMIUS si distingue per la sua forma minimalista e la sua base versatile, pensata per progetti che valorizzano il design essenziale. Realizzata in acciaio inossidabile AISI 316L, SIMIUS combina solidità strutturale con un'estetica pulita ed elegante. È una doccia solo acqua fredda o premiscelata dotata di rubinetto di apertura e chiusura. La finitura satinata e i raccordi nascosti consentono un'installazione discreta e raffinata. È perfetta per giardini, terrazze e spazi esterni con piscina.

Formal simplicity, contemporary essence

DOCCIA-SIMIUS stands out for its minimalist shape and versatile base, designed for projects that value essential design. Made of AISI 316L stainless steel, SIMIUS combines structural strength with a clean and elegant aesthetic. It is a cold water or premixed shower with an open/close tap. The satin finish and concealed fittings allow for discreet and refined installation. It is perfect for gardens, terraces and outdoor spaces with swimming pools.



DOCCIA-SIMIUS

STOCK

INOX 8025431016767



CARATTERISTICHE

- **MATERIALE ACCIAIO INOX 316L / 316L STAINLESS STEEL**
- **UGELLI ANTICALCARE / ANTI LIMESCALE NOZZLES**
- **ACCESSORI IN ACCIAIO INOX 316L / STAINLESS STEEL 316L**
- **PESO/WEIGHT 18,9 KG**
- **PACKAGING 129X56X27 CM**
- **GETTO D'ACQUA / WATER JET VERTICALE**
- **INCLUDE SACCA DI PROTEZIONE/PROTECTION BAG**
- **TRASPORTABILE CON SUPPORTO ANTIRIBALTAMENTO / TRANSPORTABLE WITH ANTI-TIP STAND**
- **SOFFIONE IN ACCIAIO/ STEEL SHOWER HEAD Ø20CM**
- **MANIGLIA APRI E CHIUDI / TURN HANDLE**
- **ACQUA FREDDA OR PREMISCELATA / WATER COLD OR PREMIXED**

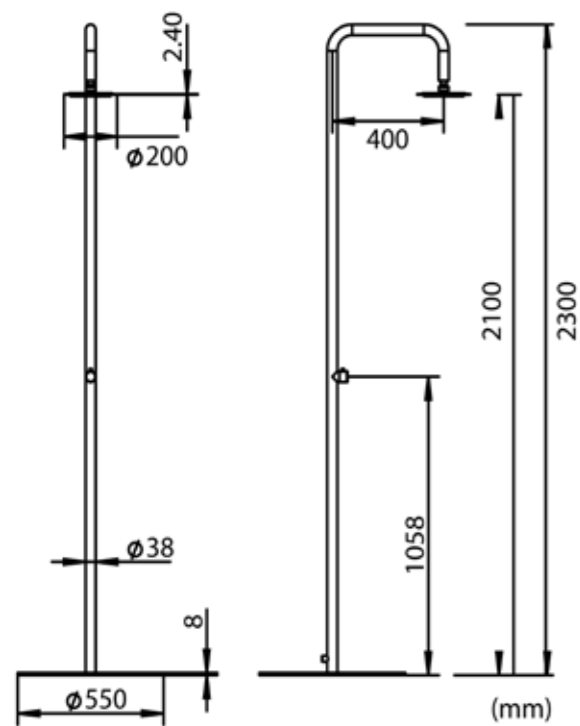

SISTEMA DI FISSAGGIO / FIXING SYSTEM
SOLO INGRESSO LATERALE 1/2 POLLICE
ONLY SIDE WATER 1/2 INCH

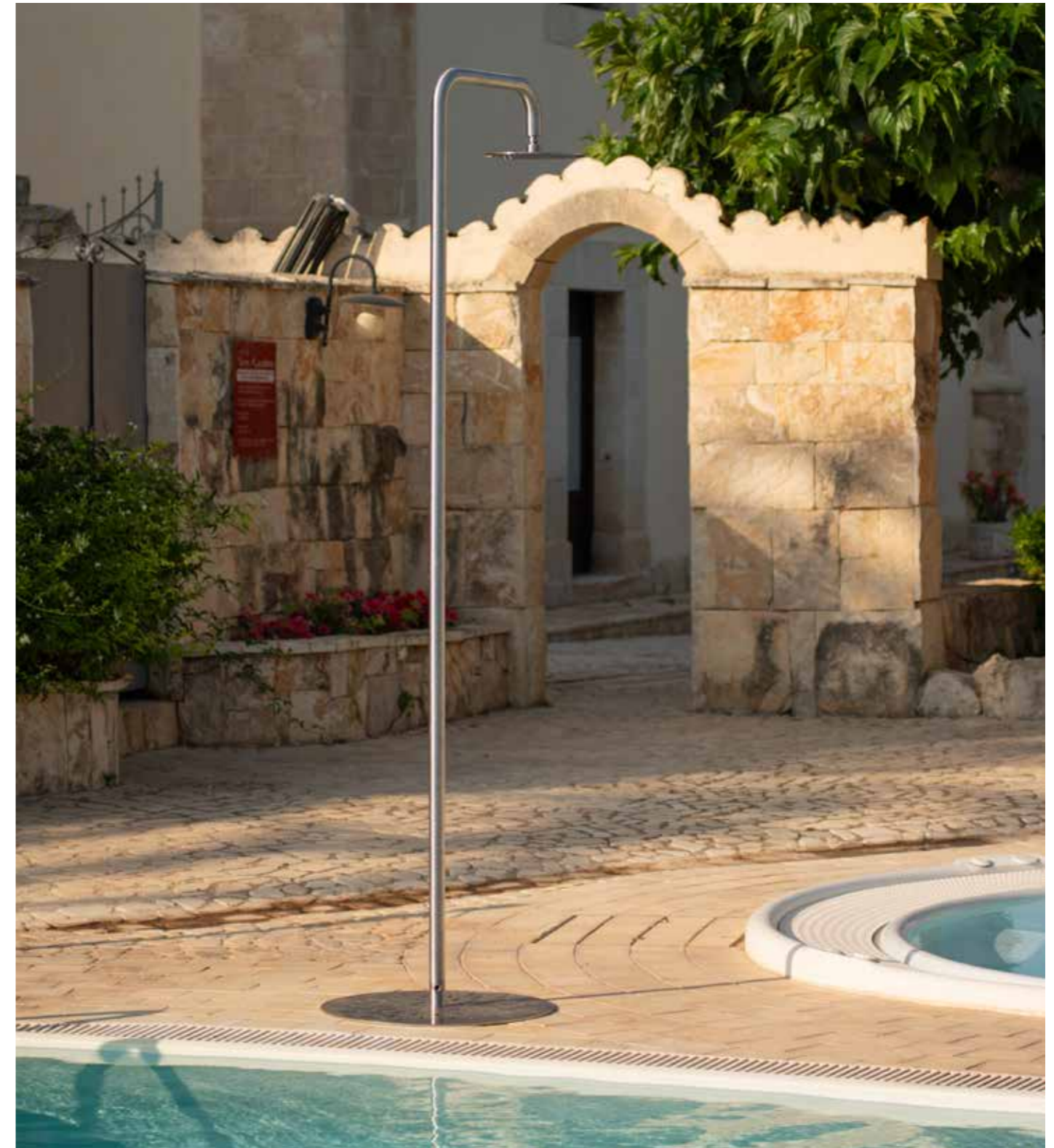

DOCCIA PALAU FREDDA

Solo Acqua fredda o premiscelata con installazione c-box

Essenzialità verticale per spazi outdoor raffinati

Realizzata in acciaio inox marino AISI 316L con finitura satinata, PALAU FREDDA è concepita esclusivamente per acqua fredda, ideale per giardini, piscine, terrazze e spiagge.

La sua silhouette slanciata e minimalista si integra con eleganza in qualsiasi ambiente esterno, offrendo un'esperienza di benessere semplice ma di impatto.

Facile da installare e resistente agli agenti atmosferici e alla corrosione, rappresenta una scelta duratura e di carattere per progettazioni outdoor contemporanee.

Vertical simplicity for refined outdoor spaces

Made of AISI 316L marine stainless steel with a satin finish, PALAU FREDDA is designed exclusively for cold water, ideal for gardens, swimming pools, terraces and beaches.

Its slender, minimalist silhouette blends elegantly into any outdoor environment, offering a simple yet striking wellness experience.

Easy to install and resistant to atmospheric agents and corrosion, it is a durable and characterful choice for contemporary outdoor designs.



DOCCIA-PALAU-FREDDA



STOCK

INOX 8025431150959

CARATTERISTICHE

- **MATERIALE ACCIAIO INOX 316L / 316L STAINLESS STEEL**
- **UGELLI ANTICALCARE / ANTI LIMESCALE NOZZLES**
- **ACCESSORI IN ACCIAIO INOX 316L / STAINLESS STEEL 316L**
- **PESO/WEIGHT 18,9 KG**
- **PACKAGING 129X56X27 CM**
- **GETTO D'ACQUA / WATER JET VERTICALE**
- **INCLUDE SACCA DI PROTEZIONE/PROTECTION BAG**
- **SOFFIONE IN ACCIAIO/ STEEL SHOWER HEAD Ø25CM**
- **MANIGLIA APRI E CHIUDI / TURN HANDLE**
- **ACQUA FREDDA O PREMISCELATA / WATER COLD OR PREMIXED**

SISTEMA DI FISSAGGIO/FIXING SYSTEM C-BOX

*ULTERIORI INFORMAZIONI
*MORE INFORMATION PAG 283



SCANSIONA PER VEDERE IL VIDEO DEL MONTAGGIO
SCAN TO VIEW THE ASSEMBLY VIDEO

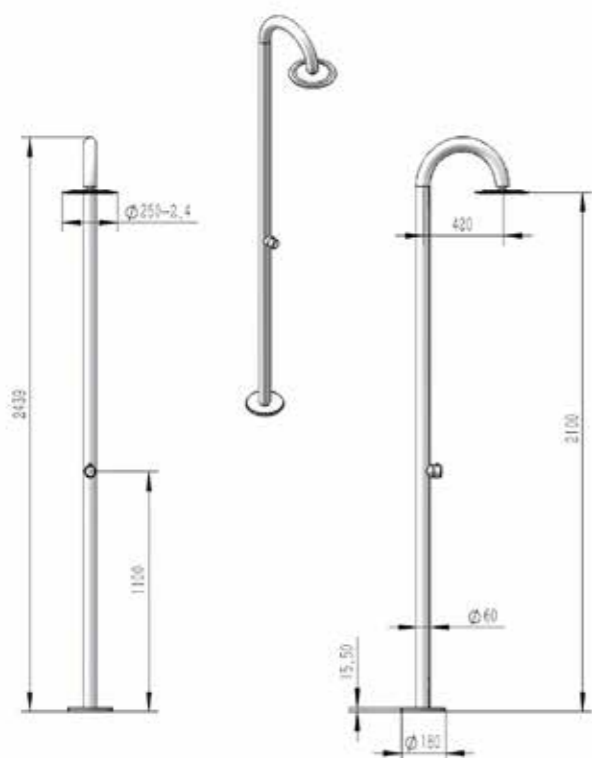

RUBINETTI ALTI DA APPOGGIO PER VASCHE FREESTANDING HIGH FREE STANDING FAUCETS

I rubinetti alti da appoggio per vasche freestanding di SINED interpretano l'elemento dell'acqua con una forte identità estetica e una presenza architettonica definita.

Realizzati in acciaio inox marino AISI 316L, questi elementi uniscono proporzioni eleganti e materiali di alta qualità per resistere duramente all'uso quotidiano e alle condizioni esterne più impegnative.

La loro silhouette slanciata e il design accurato trasformano il punto di erogazione in un vero e proprio elemento di arredo, capace di definire e completare l'installazione della vasca da esterno.

Pensati per un'estetica coerente con i linguaggi formali contemporanei, questi rubinetti offrono un equilibrio perfetto tra funzionalità e rigore progettuale.

Ideali per progetti residenziali e hospitality di alto profilo, rappresentano una scelta di stile per chi non rinuncia alla qualità e all'eleganza.

SINED's high free-standing faucets for freestanding tubs express water delivery with a strong aesthetic identity and architectural presence.

Crafted from marine-grade AISI 316L stainless steel, these pieces combine elegant proportions with premium materials designed to withstand daily use and demanding outdoor conditions.

Their refined, vertical silhouette transforms the faucet into an integral design element that enhances and completes the outdoor tub installation.

With a minimalist language and contemporary formal balance, these faucets offer the perfect interplay of performance and design intent.

Ideal for high-end residential projects and hospitality environments, they stand as a stylistic choice for those who value quality and enduring elegance.



DOCCIA-ORISTANO



STOCK

 **INOX** 8025431018617

PVD  **NERA** 8025431150942

CARATTERISTICHE

- **MATERIALE ACCIAIO INOX 316L / 316L STAINLESS STEEL**
- **UGELLI ANTICALCARE / ANTI LIMESCALE NOZZLES**
- **ACCESSORI IN ACCIAIO INOX 316L / STAINLESS STEEL 316L**
- **PESO/WEIGHT 8,5 KG**
- **PACKAGING 110X42X26 CM**
- **HASSEM CARTUCCIA/CARTRIDGE**
- **INCLUDE SACCA DI PROTEZIONE/PROTECTION BAG**
- **AERATORE NEOPERL / NEOPERL ADJUSTEMENT AERATOR**
- **MISCELATORE/MIXER UNICO CON CARTUCCIA PROGRESSIVA A 3 VIE/WAY CHE REGOLA:**
 - INTENSITÀ DEL GETTO / JET INTENSITY
 - TEMPERATURA CALDA-FREDDA / HOT-COLD
 - DIREZIONE DELL'ACQUA/DIRECTION OF WATER
- **ACQUA CALDA E FREDDA / WATER HOT AND COLD**

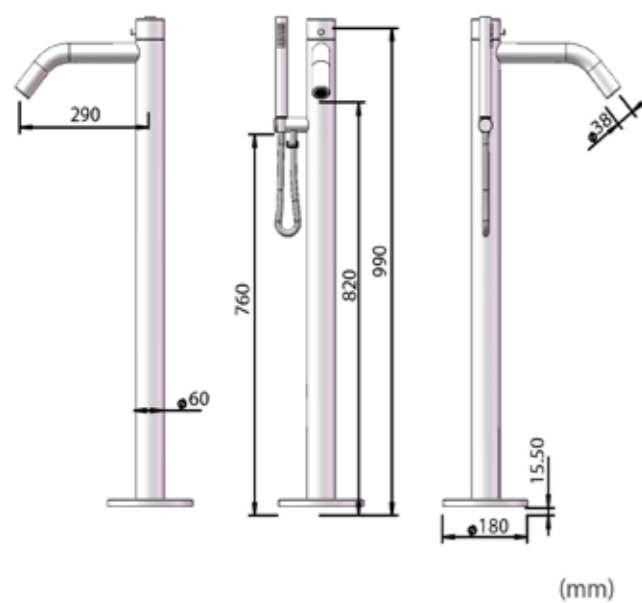

SISTEMA DI FISSAGGIO/FIXING SYSTEM C-BOX

*ULTERIORI INFORMAZIONI
*MORE INFORMATION PAG 283



SCANSIONA PER VEDERE IL VIDEO DEL MONTAGGIO

SCAN TO VIEW THE ASSEMBLY VIDEO



DOCCIA-CALASETTA



STOCK

 INOX 8025431155701

PVD  ORO-ROSA 8025431156210

CARATTERISTICHE

- **MATERIALE ACCIAIO INOX 316L / 316L STAINLESS STEEL**
- **UGELLI ANTICALCARE / ANTI LIMESCALE NOZZLES**
- **ACCESSORI IN ACCIAIO INOX 316L / STAINLESS STEEL 316L**
- **PESO/WEIGHT 8,5 KG**
- **PACKAGING 110X42X26 CM**
- **WANHAI CARTUCCIA/CARTRIDGE**
- **INCLUDE SACCA DI PROTEZIONE/PROTECTION BAG**
- **NEOPERL ADJUSTMENT AERATOR**
- **ACQUA CALDA E FREDDA / WATER HOT AND COLD**



SISTEMA DI FISSAGGIO/FIXING SYSTEM MINI C-BOX

*ULTERIORI INFORMAZIONI
*MORE INFORMATION PAG 285

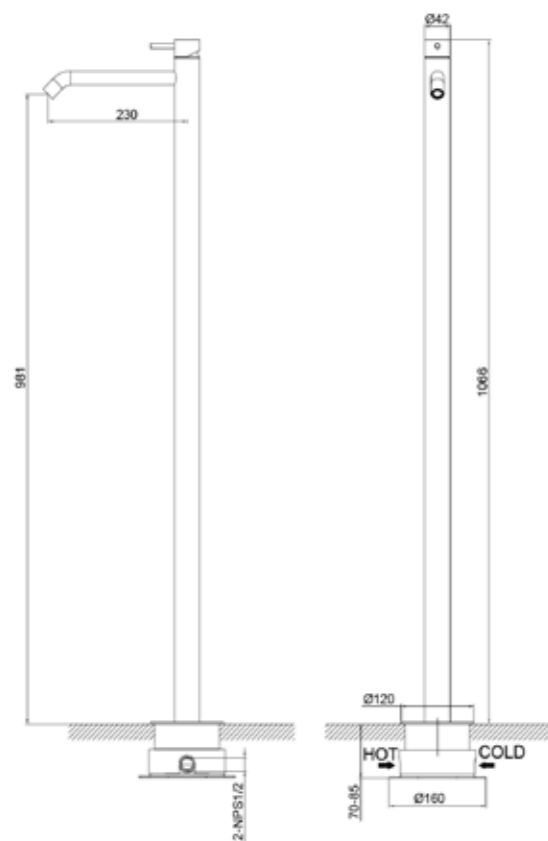

DOCCIA-CARLOFORTE



STOCK

 INOX 8025431155695

PVD  ORO-ROSA 8025431156227

CARATTERISTICHE

- **MATERIALE ACCIAIO INOX 316L / 316L STAINLESS STEEL**
- **UGELLI ANTICALCARE / ANTI LIMESCALE NOZZLES**
- **ACCESSORI IN ACCIAIO INOX 316L / STAINLESS STEEL 316L**
- **PESO/WEIGHT 8,5 KG**
- **PACKAGING 110X42X26 CM**
- **WANHAI CARTUCCIA/CARTRIDGE**
- **INCLUDE SACCA DI PROTEZIONE/PROTECTION BAG**
- **MISCELATORE/MIXER UNICO CON CARTUCCIA PROGRESSIVA A 3 VIE/WAY CHE REGOLA:**
 - INTENSITÀ DEL GETTO / JET INTENSITY
 - TEMPERATURA CALDA-FREDDA / HOT-COLD
 - DIREZIONE DELL'ACQUA/DIRECTION OF WATER
- **NEOPERL ADJUSTMENT AERATOR**
- **ACQUA CALDA E FREDDA / WATER HOT AND COLD**

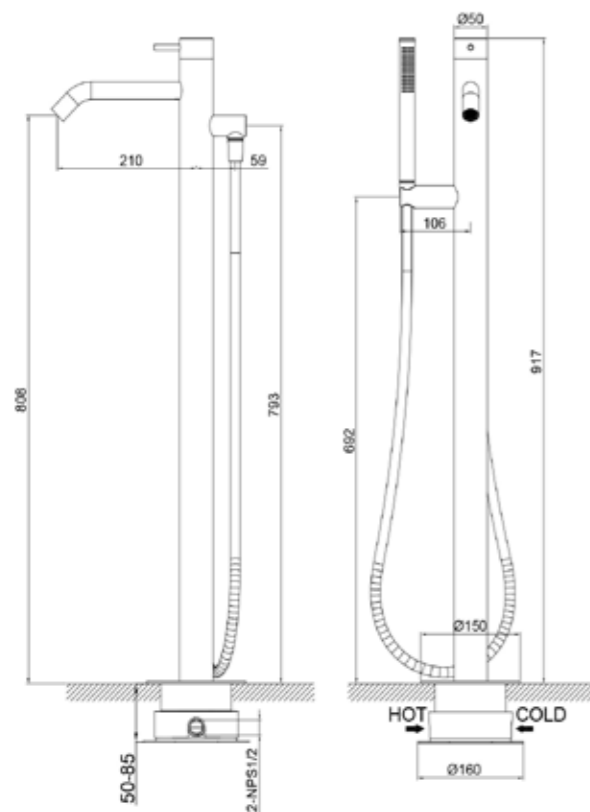

SISTEMA DI FISSAGGIO/FIXING SYSTEM MINI C-BOX

*ULTERIORI INFORMAZIONI
*MORE INFORMATION PAG 285



DOCCE DA PARETE ACCIAIO INOX 316L PER ESTERNO E INTERNO

WALL-MOUNTED STAINLESS 316L SHOWERS FOR OUTDOOR AND INDOOR USE

La collezione di docce da parete SINED in acciaio inox marino AISI 316L nasce dall'incontro tra rigore formale e funzionalità quotidiana.

Progettate per integrarsi con naturalezza in contesti sia interni che esterni, queste soluzioni esprimono un linguaggio progettuale contemporaneo, fatto di linee pure, proporzioni equilibrate e dettagli discreti.

La qualità dei materiali garantisce una resistenza superiore alla corrosione e agli agenti atmosferici, assicurando durabilità nel tempo senza compromessi.

Le finiture curate e la presenza sottile rendono queste docce perfette tanto per bagni residenziali di design quanto per ambienti hospitality di alto profilo.

Versatili, eleganti e affidabili, incarnano l'approccio SINED alla doccia da parete: performante nelle prestazioni, essenziale nell'estetica.

SINED's collection of wall-mounted showers in marine-grade AISI 316L stainless steel embodies the union of formal rigor and everyday functionality.

Designed to integrate seamlessly in both interior and exterior environments, these solutions speak a contemporary design language of pure lines, balanced proportions and discreet detailing.

The premium material ensures superior resistance to corrosion and atmospheric exposure, delivering long-lasting performance without compromise.

With refined finishes and a subtle presence, these showers are ideal for both bespoke residential bathrooms and high-end hospitality settings.

Versatile, elegant and reliable, they reflect SINED's approach to wall-mounted showers: high performance in use, essential in design.



DOCCE DA PARETE LEVANTE

Design a parete, essenza modulare

Doccia da parete in acciaio inox 316L con design contemporaneo e presenza sottile. La versione termostatica offre comfort immediato e controllo semplice della temperatura. Linee pulite e proporzioni equilibrate si integrano con eleganza in contesti indoor e outdoor. Una soluzione raffinata e funzionale per ambienti residenziali e professionali.

Wall-mounted design, modular essence

Wall-mounted shower in 316L stainless steel with a contemporary design and subtle presence. The thermostatic version offers immediate comfort and simple temperature control. Clean lines and balanced proportions integrate elegantly into indoor and outdoor settings. A refined and functional solution for residential and professional environments.



DOCCIA-PARETE-LEVANTE



STOCK

INOX 8025431155909

PVD ORO-ROSA 8025431156234

CARATTERISTICHE

- **MATERIALE ACCIAIO INOX 316L / 316L STAINLESS STEEL**
- **UGELLI ANTICALCARE / ANTI LIMESCALE NOZZLES**
- **ACCESSORI IN ACCIAIO INOX 316L / STAINLESS STEEL 316L**
- **PESO/WEIGHT 8 KG**
- **PACKAGING 102X62X18 CM**
- **INSTALLATION WITH 3 FIXING POINTS**
- **CERTIFICATED FOR INDOOR AND OUTDOOR**
- **CONNESSIONE ACQUA CALDA IN ENTRATA LATO SINISTRO / HOT WATER CONNECTION ON THE LEFT SIDE**
- **IL DEVIATORE CONTROLLA LA DIREZIONE DELL'ACQUA E CONSENTE DI CHIUDERE IL FLUSSO / THE DIVERTER CONTROLS THE DIRECTION OF THE WATER AND ALLOWS THE FLOW TO BE SHUT OFF.**
- **IL MISCELATORE REGOLA LA TEMPERATURA DELL'ACQUA / THE MIXER REGULATES THE WATER TEMPERATURE**
- **ACQUA CALDA E FREDDA / WATER HOT AND COLD**

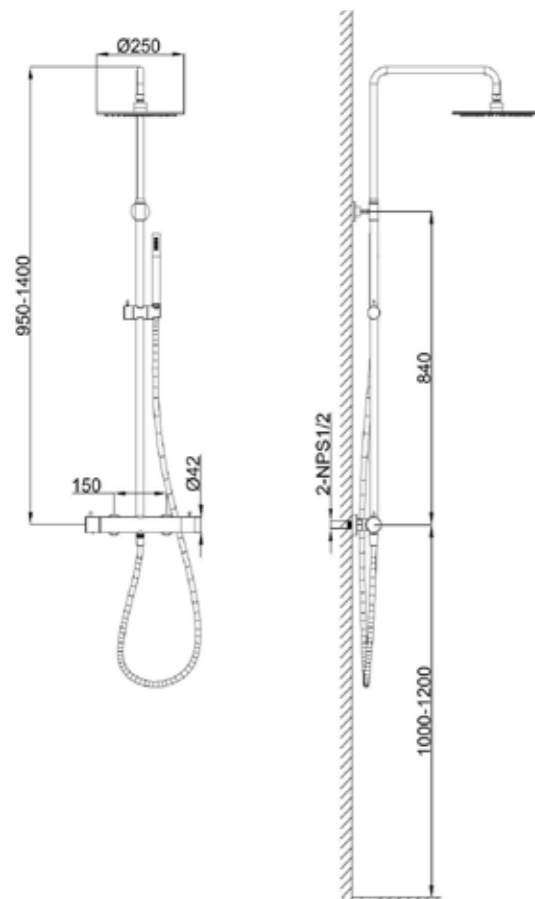

DOCCIA-PARETE-LEVANTE-TERMOSTATICA



STOCK

INOX 8025431155916

PVD CANNA-FUCILE 8025431157903

PVD ORO-ROSA 8025431156241

PVD NERA 8025431157927 *

PVD ORO 8025431157910 *

*DISPONIBILE SOLO SU ORDINAZIONE

*AVAILABLE ONLY UPON REQUEST

CARATTERISTICHE

- **MATERIALE ACCIAIO INOX 316L / 316L STAINLESS STEEL**
- **UGELLI ANTICALCARE / ANTI LIMESCALE NOZZLES**
- **ACCESSORI IN ACCIAIO INOX 316L / STAINLESS STEEL 316L**
- **PESO/WEIGHT 8 KG**
- **PACKAGING 102X62X18 CM**
- **CERTIFICATED FOR INDOOR AND OUTDOOR**
- **IL DEVIATORE CONTROLLA LA DIREZIONE DELL'ACQUA E CONSENTE DI CHIUDERE IL FLUSSO / THE DIVERTER CONTROLS THE DIRECTION OF THE WATER AND ALLOWS THE FLOW TO BE SHUT OFF.**
- **IL MISCELATORE REGOLA LA TEMPERATURA DELL'ACQUA / THE MIXER REGULATES THE WATER TEMPERATURE**
- **CONNESSIONE ACQUA CALDA IN ENTRATA LATO SINISTRO / HOT WATER CONNECTION ON THE LEFT SIDE**
- **GETTO D'ACQUA / WATER JET VERTICAL**
- **CARTUCCIA TERMOSTATICA VERNET SPECIFICA PER IL MODELLO LEVANTE-TERMOSTATICA**
- **ACQUA CALDA E FREDDA / WATER HOT AND COLD**

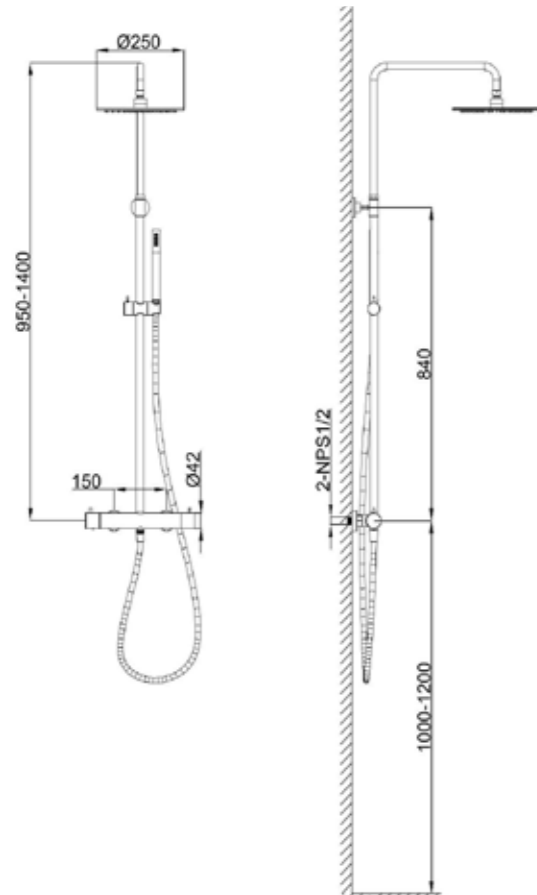

DOCCE DA PARETE ARBOREA & CABRAS

Design a parete, essenza modulare

Interpretazione murale del design funzionale, queste docce in acciaio inox AISI 316L coniugano sobrietà formale e resistenza architettonica.

ARBOREA, con soffione superiore e doccetta; CABRAS, con sola doccetta, esprimono due visioni della stessa essenza: una più scultorea, l'altra più discreta.

Entrambe dotate di sistema di fissaggio C-BOX e connessioni invisibili, permettono un'installazione pulita e armoniosa.

Pensate per ambienti outdoor dove purezza formale e durata tecnica diventano protagonisti.

Wall-mounted design, modular essence

A wall-mounted interpretation of functional design, these AISI 316L stainless steel showers combine formal restraint with architectural endurance.

ARBOREA, with overhead and hand shower; CABRAS, with only hand shower, offer two takes on the same essence—one more sculptural, the other more discreet.

Both include C-BOX fixing and concealed connections, enabling seamless and refined installation.

Conceived for outdoor spaces where purity of form and technical longevity take center stage.



DOCCIA-ARBOREA

STOCK

 INOX 8025431018600

PVD  NERA 8025431150935

CARATTERISTICHE

- **MATERIALE ACCIAIO INOX 316L / 316L STAINLESS STEEL**
- **UGELLI ANTICALCARE / ANTI LIMESCALE NOZZLES**
- **ACCESSORI IN ACCIAIO INOX 316L / STAINLESS STEEL 316L**
- **PESO/WEIGHT 8 KG**
- **PACKAGING 102X62X18 CM**
- **CERTIFICATED FOR INDOOR AND OUTDOOR**
- **INCLUDES SACCA PROTEZIONE/ PROTECTION BAG**
- **MISCELATORE/MIXER UNICO CON CARTUCCIA PROGRESSIVA A 3 VIE/WAY CHE REGOLA:**
 - INTENSITÀ DEL GETTO / JET INTENSITY
 - TEMPERATURA CALDA-FREDDA / HOT-COLD
 - DIREZIONE DELL'ACQUA/DIRECTION OF WATER
- **GETTO D'ACQUA / WATER JET VERTICAL**
- **PARTE ORIZZONTALE NON REVERSIBILE, MONTAGGIO SOLO A DESTRA / NON-REVERSIBLE HORIZONTAL SECTION, RIGHT-SIDE MOUNTING ONLY**
- **CONNESSIONE ACQUA CALDA IN ENTRATA LATO SINISTRO / HOT WATER CONNECTION ON THE LEFT SIDE**
- **ACQUA CALDA E FREDDA / WATER HOT AND COLD**

FIXING SYSTEM WITH 3 POINTS

*WATCH VIDEO OF THE ASSEMBLY

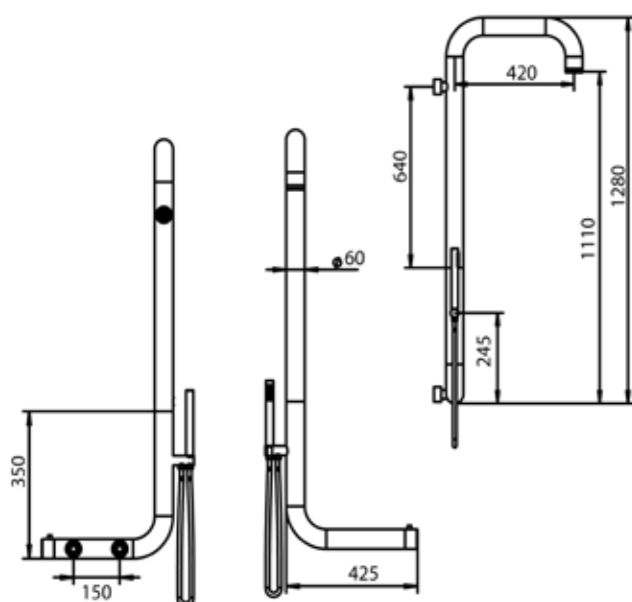

DOCCIA-CABRAS

STOCK

INOX 8025431153080

PVD NERA 8025431153097

CARATTERISTICHE

- **MATERIALE ACCIAIO INOX 316L / 316L STAINLESS STEEL**
- **UGELLI ANTICALCARE / ANTI LIMESCALE NOZZLES**
- **ACCESSORI IN ACCIAIO INOX 316L / STAINLESS STEEL 316L**
- **PESO/WEIGHT 8 KG**
- **PACKAGING 102X62X18 CM**
- **CERTIFICATED FOR INDOOR AND OUTDOOR**
- **INCLUDES SACCA PROTEZIONE/ PROTECTION BAG**
- **MISCELATORE/MIXER UNICO CON CARTUCCIA PROGRESSIVA A 3 VIE/WAY CHE REGOLA:**
 - INTENSITÀ DEL GETTO / JET INTENSITY
 - TEMPERATURA CALDA-FREDDA / HOT-COLD
 - DIREZIONE DELL'ACQUA/DIRECTION OF WATER
- **GETTO D'ACQUA / WATER JET VERTICAL**
- **PARTE ORIZZONTALE NON REVERSIBILE, MONTAGGIO SOLO A DESTRA / NON-REVERSIBLE HORIZONTAL SECTION, RIGHT-SIDE MOUNTING ONLY**
- **CONNESSIONE ACQUA CALDA IN ENTRATA LATO SINISTRO / HOT WATER CONNECTION ON THE LEFT SIDE**
- **ACQUA CALDA E FREDDA / WATER HOT AND COLD**



FIXING SYSTEM WITH 3 POINTS

*WATCH VIDEO OF THE ASSEMBLY

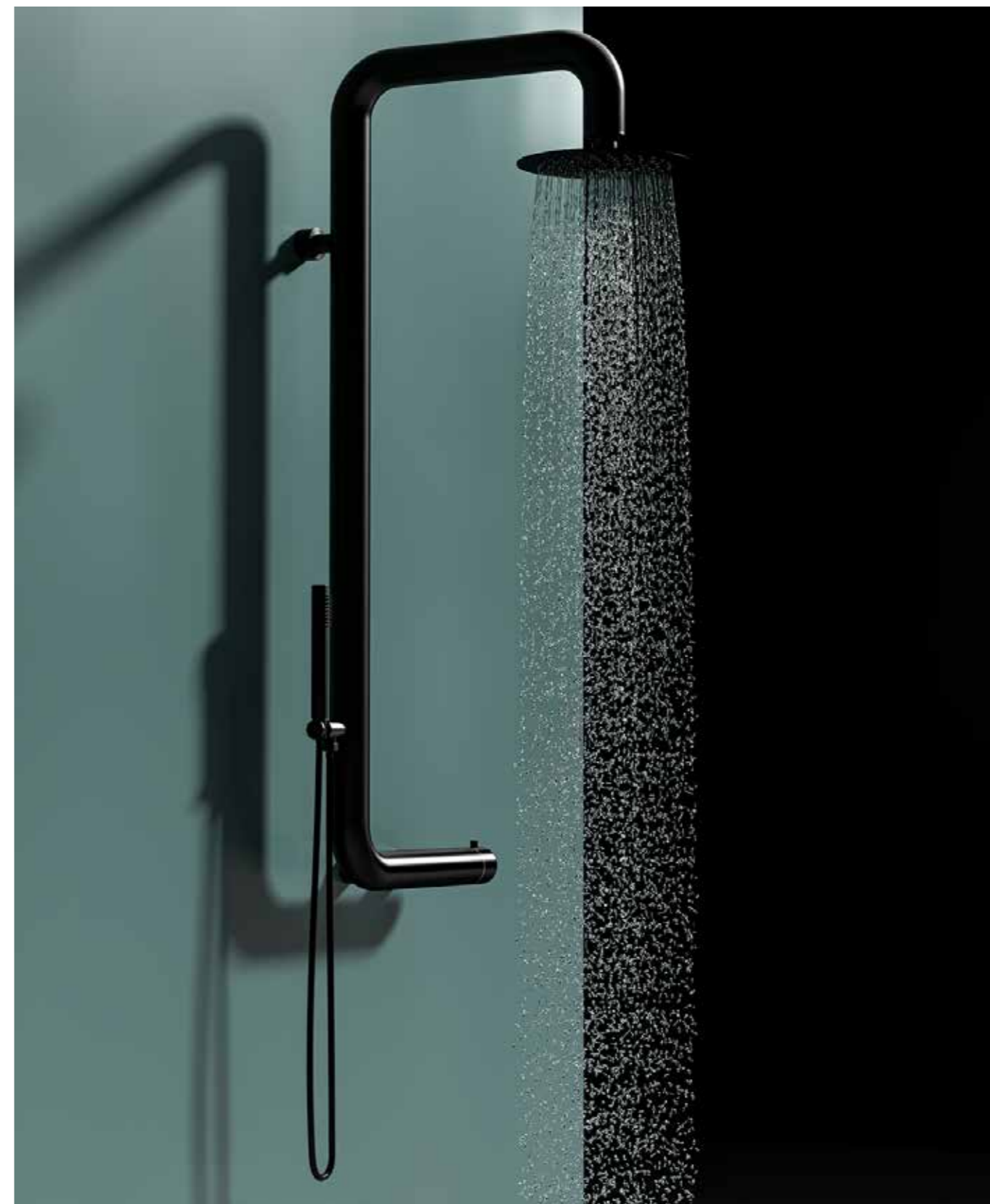
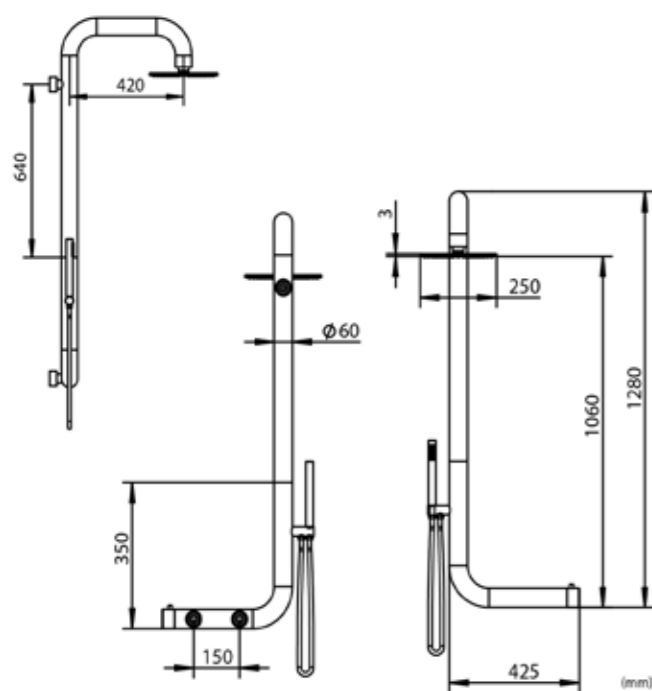

DOCCE DA PARETE CHIA & PULA

Linee pure per l'architettura indoor e outdoor

Progettate per integrarsi con eleganza a parete o su pannelli strutturali, CHIA-PARETE e PULA-PARETE reinterpretano il concetto di doccia murale con uno sguardo tecnico e minimale.

Entrambe in acciaio inox marino AISI 316L, condividono geometrie precise, finiture satiniate e connessioni invisibili.

CHIA-PARETE include soffione e doccetta; PULA-PARETE, solo doccetta, perfetta per contesti più contenuti.

Un sistema versatile, funzionale e dall'impronta architettonica.
Perfetto anche per i bagni interni di ville e hotel in riva la mare.

Pure lines for architectural indoor and outdoor design

Designed to integrate elegantly onto walls or structural panels, CHIA-PARETE and PULA-PARETE reinterpret the wall-mounted shower through a technical, minimalist lens.

Both made of marine-grade stainless steel AISI 316L, they share precise geometry, satin finishes, and hidden connections.

CHIA-PARETE features both overhead and hand shower; PULA-PARETE, hand shower only—ideal for more compact spaces.

A versatile, functional system with architectural presence.
Also perfect for indoor bathrooms in villas and hotels by the sea.



DOCCIA-CHIA-PARETE

STOCK

 INOX 8025431153028

PVD  NERA 8025431153035

CARATTERISTICHE

- **MATERIALE ACCIAIO INOX 316L / 316L STAINLESS STEEL**
- **UGELLI ANTICALCARE / ANTI LIMESCALE NOZZLES**
- **ACCESSORI IN ACCIAIO INOX 316L / STAINLESS STEEL 316L**
- **PESO/WEIGHT 10 KG**
- **PACKAGING 120X582X20 CM**
- **CERTIFICATED FOR INDOOR AND OUTDOOR**
- **INCLUDES SACCA PROTEZIONE/ PROTECTION BAG**
- **IL DEVIATORE CONTROLLA LA DIREZIONE DELL'ACQUA E CONSENTE DI CHIUDERE IL FLUSSO / THE DIVERTER CONTROLS THE DIRECTION OF THE WATER AND ALLOWS THE FLOW TO BE SHUT OFF.**
- **IL MISCELATORE REGOLA LA TEMPERATURA DELL'ACQUA / THE MIXER REGULATES THE WATER TEMPERATURE**
- **CONNESSIONE ACQUA CALDA IN ENTRATA LATO SUPERIORE / HOT WATER CONNECTION ON THE TOP SIDE**
- **GETTO D'ACQUA / WATER JET VERTICAL**
- **CONNESSIONI IN INGRESSO VERTICALI DISTANZA 15CM VERTICAL INPUT CONNECTIONS, DISTANCE 15 CM**
- **ACQUA CALDA E FREDDA / WATER HOT AND COLD**



FIXING SYSTEM WITH 3 POINTS

*WATCH VIDEO OF THE ASSEMBLY

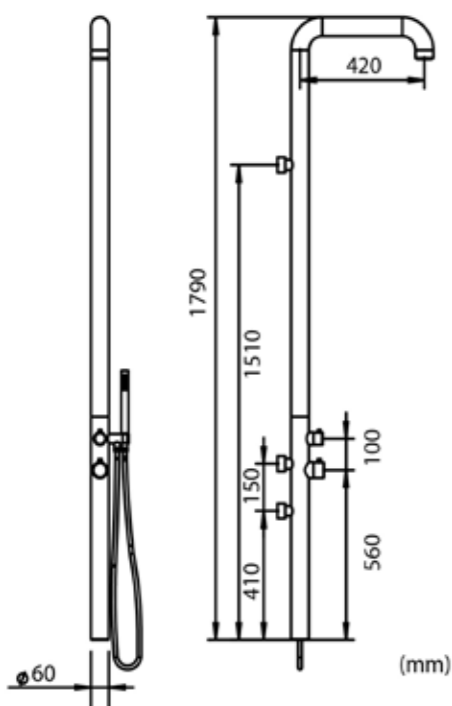

DOCCIA-PULA-PARETE

STOCK

 INOX 8025431153004

PVD  NERA 8025431153011

CARATTERISTICHE

- **MATERIALE ACCIAIO INOX 316L / 316L STAINLESS STEEL**
- **UGELLI ANTICALCARE / ANTI LIMESCALE NOZZLES**
- **ACCESSORI IN ACCIAIO INOX 316L / STAINLESS STEEL 316L**
- **PESO/WEIGHT 10 KG**
- **PACKAGING 125X58X20 CM**
- **CERTIFICATED FOR INDOOR AND OUTDOOR**
- **INCLUDES SACCA PROTEZIONE/ PROTECTION BAG**
- **IL DEVIATORE CONTROLLA LA DIREZIONE DELL'ACQUA E CONSENTE DI CHIUDERE IL FLUSSO / THE DIVERTER CONTROLS THE DIRECTION OF THE WATER AND ALLOWS THE FLOW TO BE SHUT OFF.**
- **IL MISCELATORE REGOLA LA TEMPERATURA DELL'ACQUA / THE MIXER REGULATES THE WATER TEMPERATURE**
- **CONNESSIONE ACQUA CALDA IN ENTRATA LATO SUPERIORE / HOT WATER CONNECTION ON THE TOP SIDE**
- **GETTO D'ACQUA / WATER JET VERTICAL**
- **CONNESSIONI IN INGRESSO VERTICALI DISTANZA 15CM VERTICAL INPUT CONNECTIONS, DISTANCE 15 CM**
- **ACQUA CALDA E FREDDA / WATER HOT AND COLD**



FIXING SYSTEM WITH 3 POINTS

*WATCH VIDEO OF THE ASSEMBLY

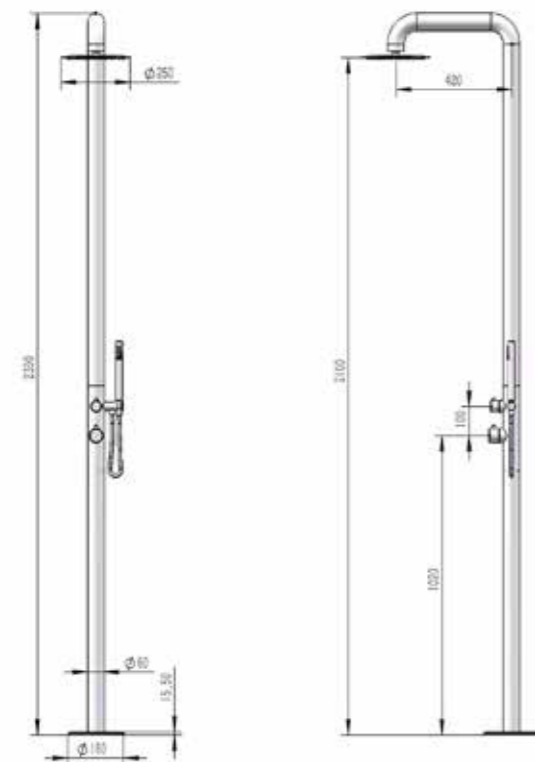
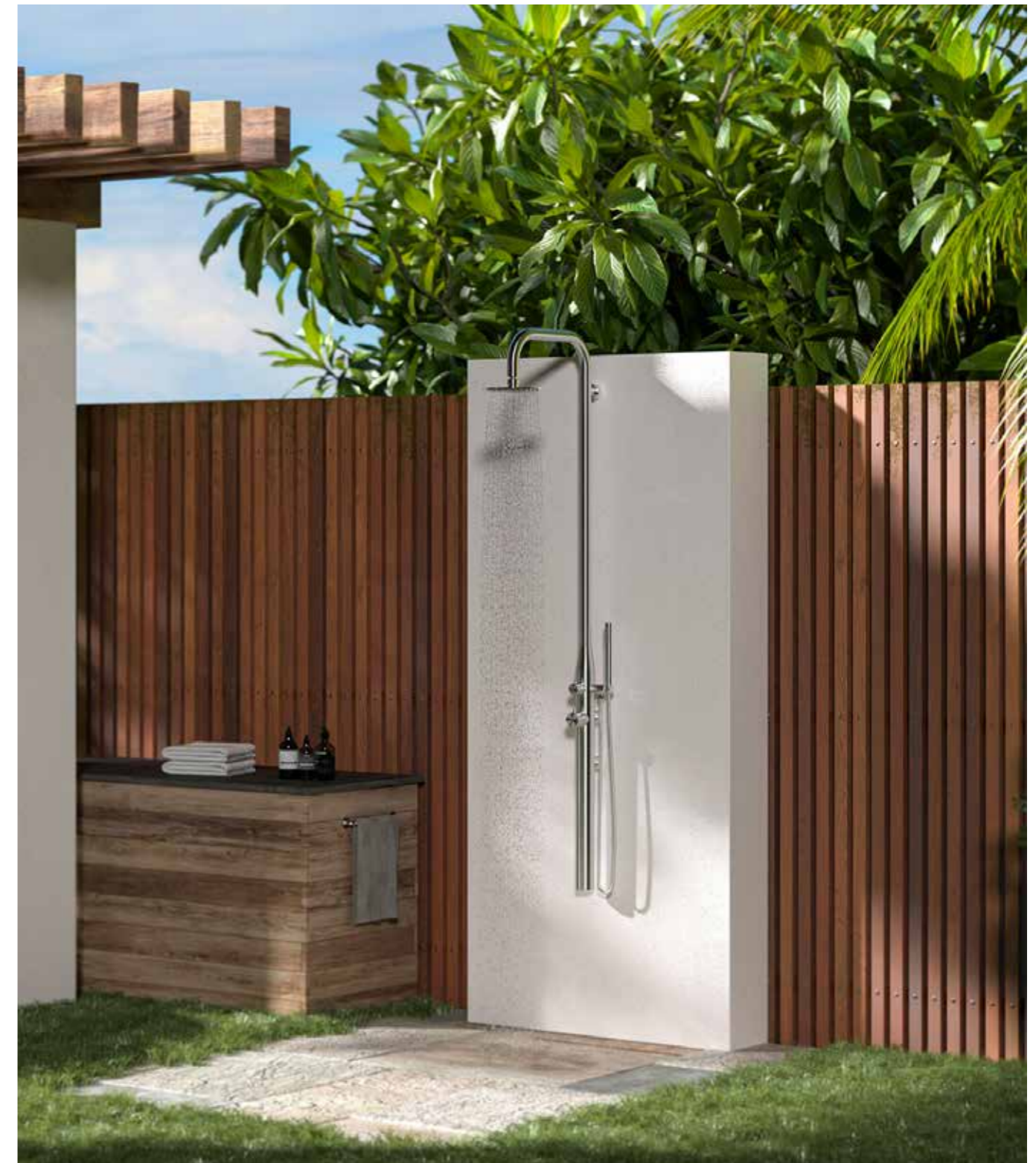

DOCCE PROFESSIONALI IN ACCIAIO INOX 316L PROFESSIONAL 316L STAINLESS STEEL SHOWERS

Le docce temporizzate SINED in acciaio inox 316L rappresentano la fusione perfetta tra estetica contemporanea, funzionalità avanzata e robustezza. Progettate per ambienti professionali e ad alta frequentazione come impianti sportivi, spa, hotel o centri benessere, queste docce garantiscono efficienza idrica, igiene impeccabile e design senza tempo.

SINED punta all'eccellenza: docce che non solo funzionano perfettamente, ma che elevano il livello di design di qualsiasi spazio.

SINED's 316L stainless steel timer showers represent the perfect fusion of contemporary aesthetics, advanced functionality and uncompromising durability. Designed for professional and high-traffic environments such as sports facilities, spas, hotels or wellness centres, these showers guarantee water efficiency, impeccable hygiene and timeless design.

SINED is committed to excellence: showers that not only work perfectly, but also raise the design level of any space.



Soluzioni innovative per stabilimenti balneari, lidi e spiagge pubbliche

Le nostre docce professionali sono progettate per resistere alle condizioni più estreme, garantendo durata, sicurezza e risparmio idrico.

Completamente realizzate in acciaio inox marino 316L, il materiale più resistente alla salsedine e alla **corrosione**. Ideali per ambienti ad alta umidità e prossimità del mare: **inattaccabili dal tempo e dall'ambiente salino**.

Monogetto: ideale per aree con spazio limitato o uso individuale.

Multitesta: per servire più persone contemporaneamente.

Tutti i modelli sono dotati di **temporizzatori automatici** per l'erogazione dell'acqua.

Contribuiscono a un utilizzo intelligente delle risorse e a una **riduzione significativa dei consumi idrici**.

Le docce SINED sono certificate per garantire il rispetto dei **più alti standard di sostenibilità**.

Scelte ideali per enti pubblici, comuni e strutture attente all'ambiente.

Consigliate in:

- Stabilimenti balneari
- Spiagge pubbliche
- Campeggi
- Hotel e resort con accesso al mare
- Marine e porti turistici

Durabilità estrema grazie all'acciaio inox 316L

Design elegante e funzionale

Rispetto per l'ambiente con dispositivi per il risparmio d'acqua

Assistenza tecnica e supporto post-vendita

Innovative solutions for beach establishments, lidos and public beaches

Our professional showers are designed to withstand the most extreme conditions, ensuring durability, safety and water savings.

Completely made of marine grade 316L stainless steel, the most salt and **corrosion resistant material**.

Ideal for high humidity environments and proximity to the sea: **inattaccabili dal tempo e dall'ambiente salino**.

Single-head: ideal for areas with limited space or individual use.

Multi-head: for serving several people at once

All models are equipped with automatic **timers for water** delivery.

They contribute to intelligent use of resources and a significant **reduction in water consumption**.

SINED showers are **certified** to ensure compliance with the **highest standards of sustainability**.

Ideal choices for public agencies, municipalities and environmentally conscious facilities.

Recommended at

- Bathing establishments
- Public beaches
- Campgrounds
- Hotels and resorts with sea access
- Marinas and marinas

Extreme durability thanks to 316L stainless steel

Elegant and functional design

Respect for the environment with water-saving devices

Technical assistance and after-sales support

DOCCE PROFESSIONALI TEMPORIZZATE

Docce professionali SINED in acciaio inox 316L – Massima resistenza per ambienti marini

Le docce professionali SINED sono realizzate interamente in acciaio inox AISI 316L, materiale di altissima qualità noto per la sua eccezionale resistenza alla corrosione da salsedine e agenti atmosferici. Ideale per ambienti pubblici marini, come stabilimenti balneari, porti turistici, spiagge attrezzate e piscine esterne, garantisce durabilità, igiene e design professionale anche nelle condizioni più estreme.

Disponibile in versione monogetto o multigetto, può essere configurata con una o più teste doccia per rispondere alle esigenze di flussi elevati di utenti. La struttura solida e il design anti-vandalico la rendono perfetta per l'uso intensivo e continuativo in spazi pubblici.

SINED professional shower in 316L stainless steel - Maximum resistance for marine environments

The SINED professional shower is made entirely of AISI 316L stainless steel, a top quality material known for its exceptional resistance to corrosion by salt spray and atmospheric agents. Ideal for public marine environments, such as bathing establishments, marinas, equipped beaches and outdoor swimming pools, it guarantees durability, hygiene and professional design even in the most extreme conditions.

Available in single or multi-jet versions, it can be configured with one or more showerheads to meet the needs of high user flows. Its solid construction and vandal-resistant design make it perfect for intensive and continuous use in public spaces.



DOCCIA-INOX-POLIFEMO



STOCK

INOX 8025431153103

CARATTERISTICHE

- **MATERIALE ACCIAIO INOX 316L / 316L STAINLESS STEEL**
- **UGELLI ANTICALCARE / ANTI LIMESCALE NOZZLES**
- **ACCESSORI IN ACCIAIO INOX 316L / STAINLESS STEEL 316L**
- **PESO/WEIGHT 17,5 KG**
- **PACKAGING 130X58X28 CM**
- **INCLUDES SACCA PROTEZIONE/ PROTECTION BAG**
- **GETTO D'ACQUA / WATER JET VERTICAL**
- **ACQUA FREDDA O PREMISCELATA / WATER COLD OR PREMIXED** ❄️
- **PULSANTE TEMPORIZZATORE RINFORZATO / REINFORCED TIMER BUTTON FUNCTION CHILD PROOF** ⌚

FIXING SYSTEM SUPER-BOX

*MORE INFORMATION PAG 284

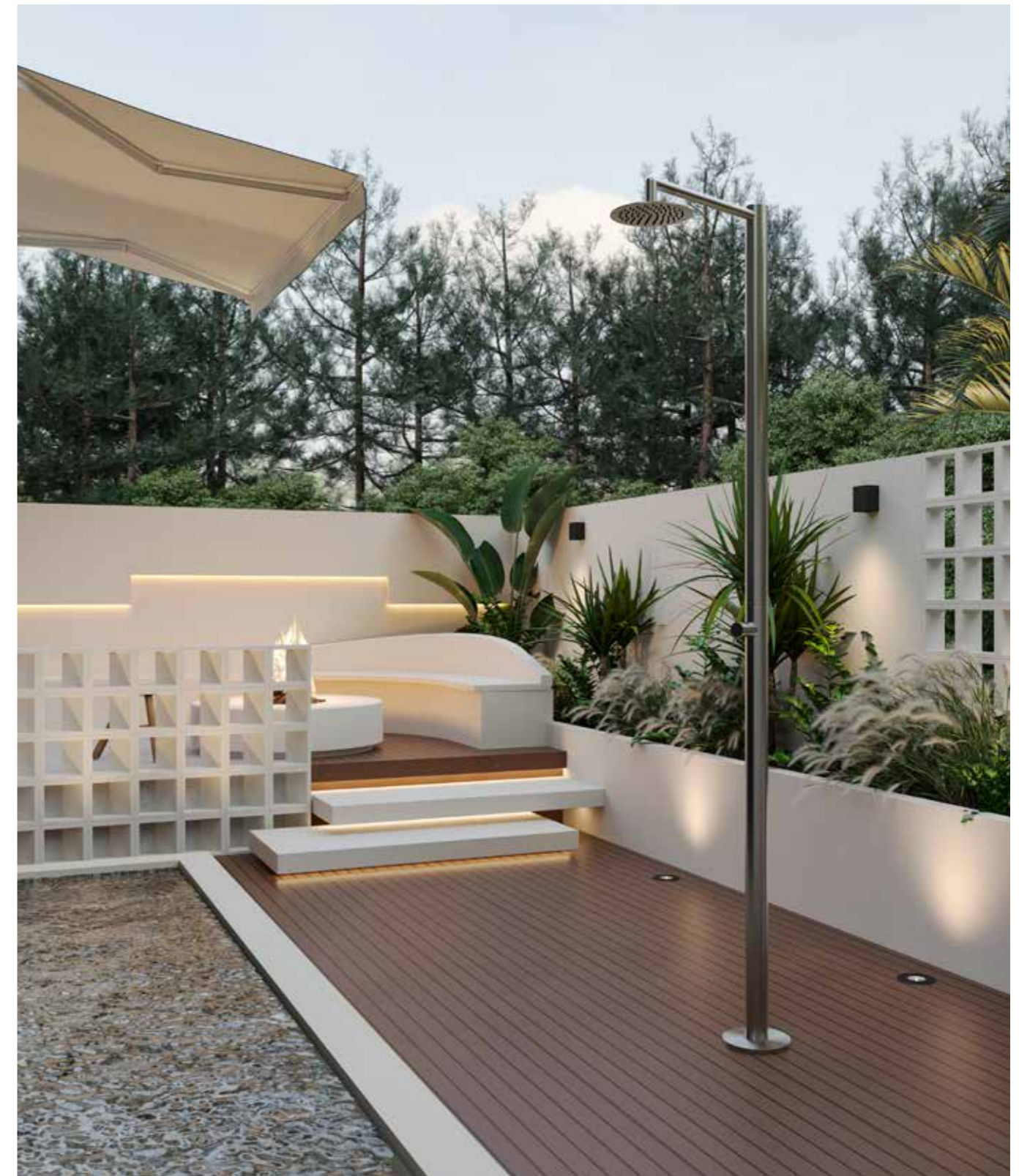
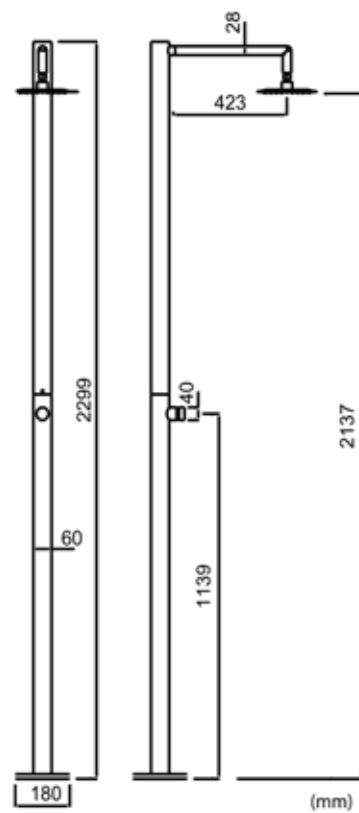

DOCCIA-INOX-ORTRO-2T



STOCK

INOX 8025431153110

CARATTERISTICHE

- **MATERIALE ACCIAIO INOX 316L / 316L STAINLESS STEEL**
- **UGELLI ANTICALCARE / ANTI LIMESCALE NOZZLES**
- **ACCESSORI IN ACCIAIO INOX 316L / STAINLESS STEEL 316L**
- **PESO/WEIGHT 17,5 KG**
- **PACKAGING 130X58X28 CM**
- **INCLUDES SACCA PROTEZIONE/ PROTECTION BAG**
- **GETTO D'ACQUA / WATER JET VERTICAL**
- **ACQUA FREDDA O PREMISCELATA / WATER COLD OR PREMIXED**
- **PULSANTE TEMPORIZZATORE RINFORZATO / REINFORCED TIMER BUTTON FUNCTION CHILD PROOF**

FIXING SYSTEM SUPER-BOX

*MORE INFORMATION PAG 284

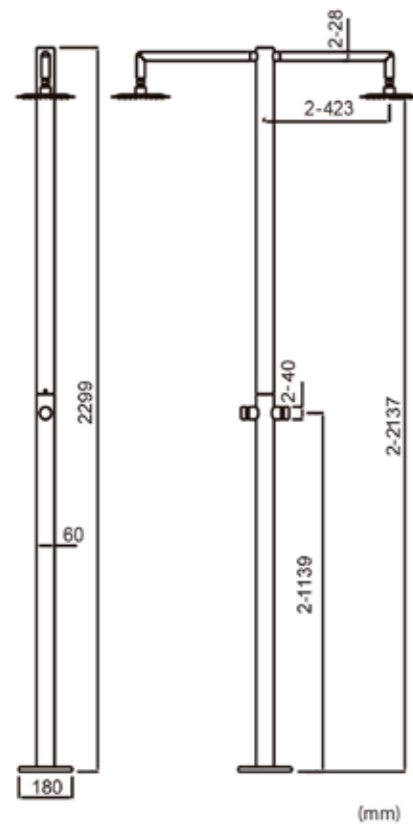

DOCCIA-INOX-CERBERO-3T



STOCK

INOX 8025431153127

CARATTERISTICHE

- **MATERIALE ACCIAIO INOX 316L / 316L STAINLESS STEEL**
- **UGELLI ANTICALCARE / ANTI LIMESCALE NOZZLES**
- **ACCESSORI IN ACCIAIO INOX 316L / STAINLESS STEEL 316L**
- **PESO/WEIGHT 17,5 KG**
- **PACKAGING 130X58X28 CM**
- **INCLUDES SACCA PROTEZIONE/ PROTECTION BAG**
- **GETTO D'ACQUA / WATER JET VERTICAL**
- **ACQUA FREDDA O PREMISCELATA / WATER COLD OR PREMIXED**
- **PULSANTE TEMPORIZZATORE RINFORZATO / REINFORCED TIMER BUTTON FUNCTION CHILD PROOF**

FIXING SYSTEM SUPER-BOX

*MORE INFORMATION PAG 284

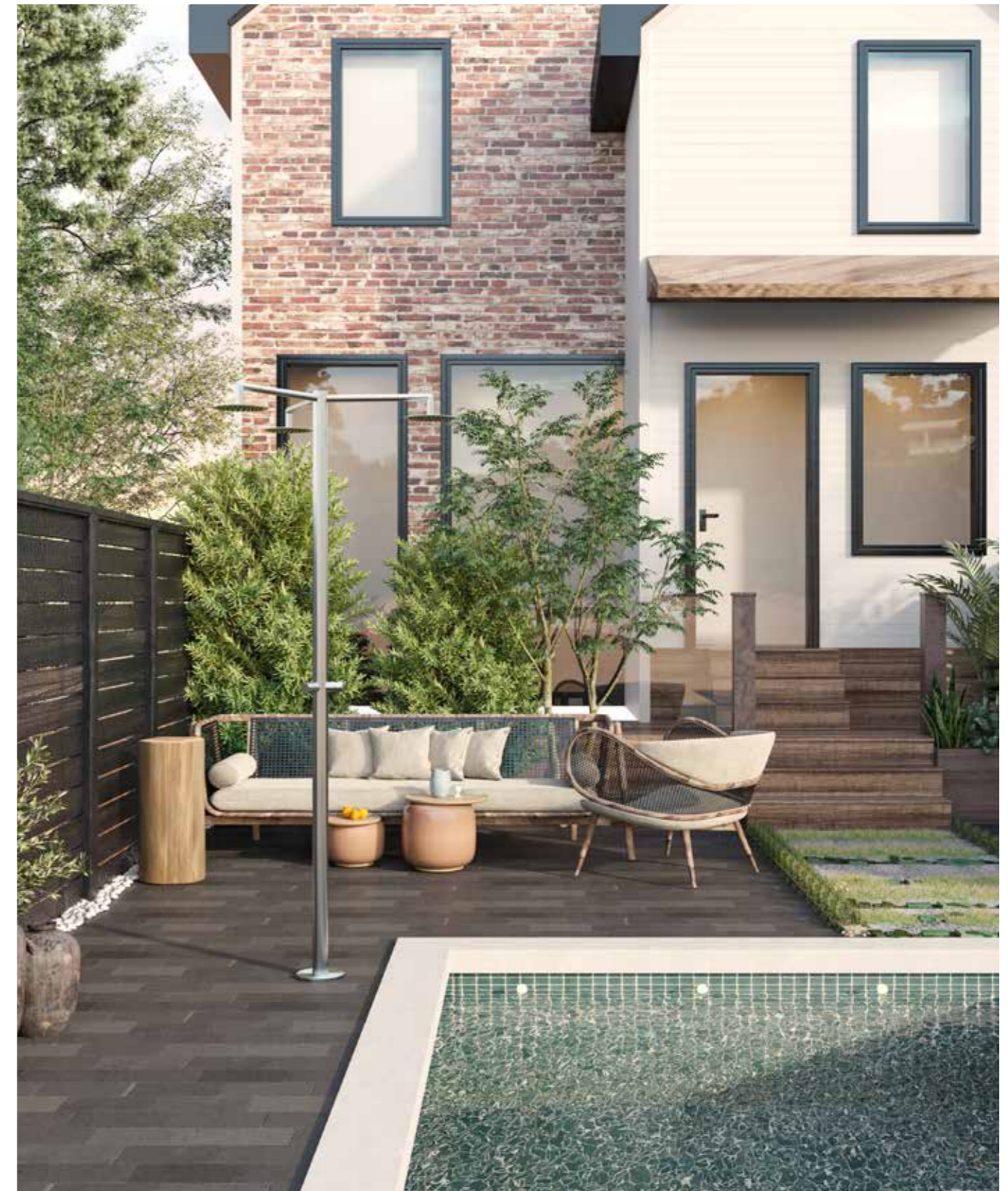
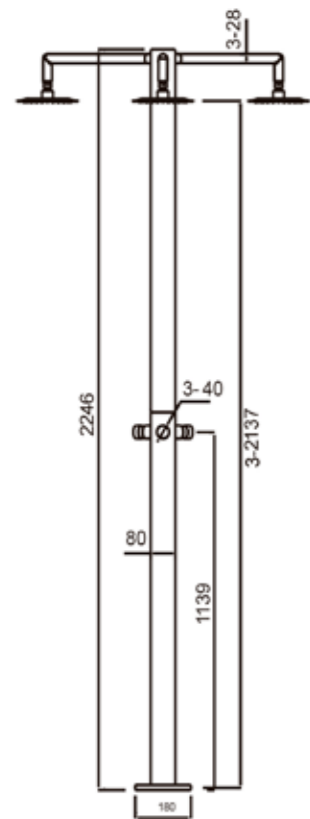

DOCCIA-INOX-IDRA-4T



STOCK

INOX 8025431153134

CARATTERISTICHE

- **MATERIALE ACCIAIO INOX 316L / 316L STAINLESS STEEL**
- **UGELLI ANTICALCARE / ANTI LIMESCALE NOZZLES**
- **ACCESSORI IN ACCIAIO INOX 316L / STAINLESS STEEL 316L**
- **PESO/WEIGHT 17,5 KG**
- **PACKAGING 130X58X28 CM**
- **INCLUDES SACCA PROTEZIONE/ PROTECTION BAG**
- **GETTO D'ACQUA / WATER JET VERTICAL**
- **ACQUA FREDDA O PREMISCELATA / WATER COLD OR PREMIXED** 
- **PULSANTE TEMPORIZZATORE RINFORZATO / REINFORCED TIMER BUTTON FUNCTION CHILD PROOF** 

FIXING SYSTEM SUPER-BOX

*MORE INFORMATION PAG 284

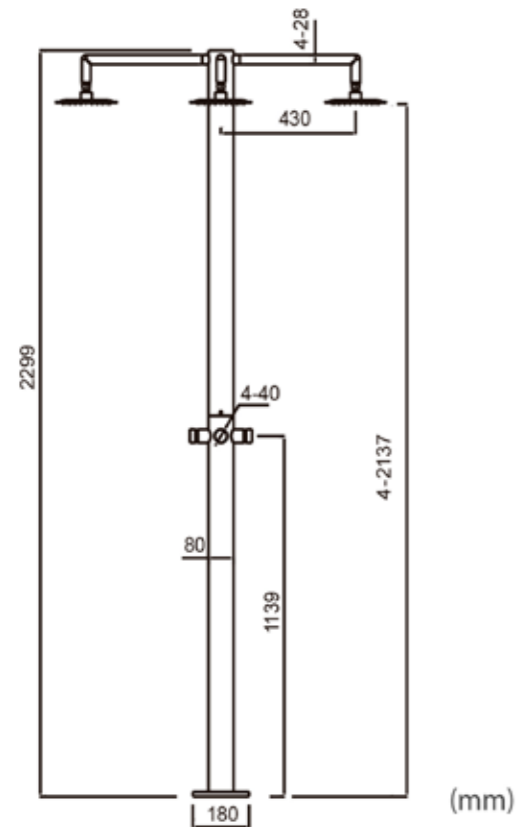



DOCCIA-INOX-MONOCOLO



STOCK

INOX 8025431154841

CARATTERISTICHE

- **MATERIALE ACCIAIO INOX 316L / 316L STAINLESS STEEL**
- **UGELLI ANTICALCARE / ANTI LIMESCALE NOZZLES**
- **ACCESSORI IN ACCIAIO INOX 316L / STAINLESS STEEL 316L**
- **PESO/WEIGHT 17,5 KG**
- **PACKAGING 130X58X28 CM**
- **INCLUDES SACCA PROTEZIONE/ PROTECTION BAG**
- **GETTO D'ACQUA / WATER JET VERTICAL**
- **ACQUA FREDDA O PREMISCELATA / WATER COLD OR PREMIXED** 
- **PULSANTE TEMPORIZZATORE RINFORZATO / REINFORCED TIMER BUTTON FUNCTION CHILD PROOF** 

FIXING SYSTEM SUPER-BOX

*MORE INFORMATION PAG 284

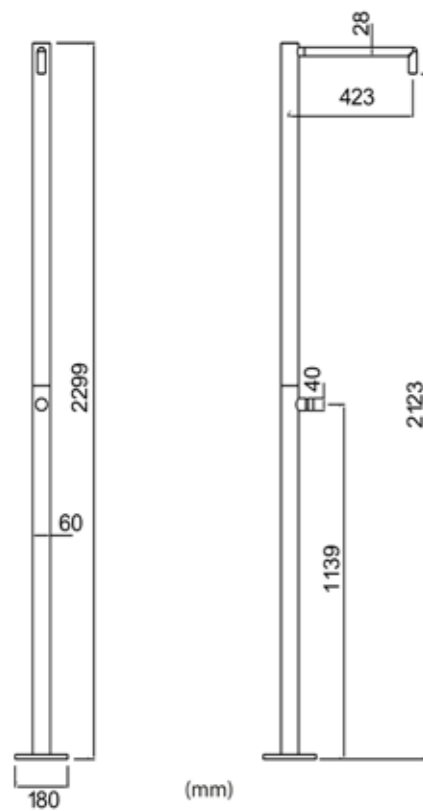

(mm)

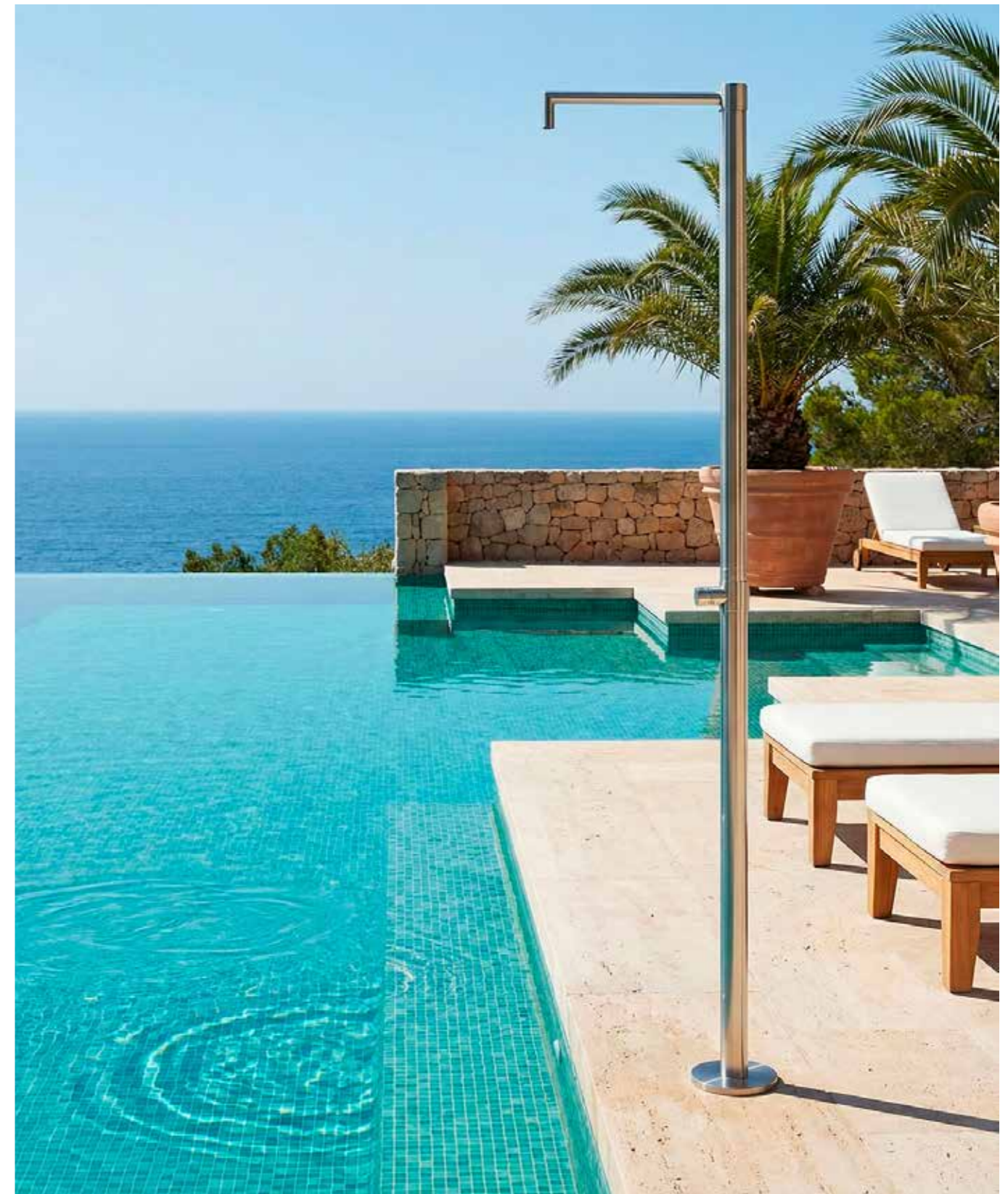



DOCCIA-INOX-BICEFALO



STOCK

INOX 8025431154858

CARATTERISTICHE

- **MATERIALE ACCIAIO INOX 316L / 316L STAINLESS STEEL**
- **UGELLI ANTICALCARE / ANTI LIMESCALE NOZZLES**
- **ACCESSORI IN ACCIAIO INOX 316L / STAINLESS STEEL 316L**
- **PESO/WEIGHT 17,5 KG**
- **PACKAGING 130X58X28 CM**
- **INCLUDES SACCA PROTEZIONE/ PROTECTION BAG**
- **GETTO D'ACQUA / WATER JET VERTICAL**
- **ACQUA FREDDA O PREMISCELATA / WATER COLD OR PREMIXED** 
- **PULSANTE TEMPORIZZATORE RINFORZATO / REINFORCED TIMER BUTTON FUNCTION CHILD PROOF** 

FIXING SYSTEM SUPER-BOX

*MORE INFORMATION PAG 284

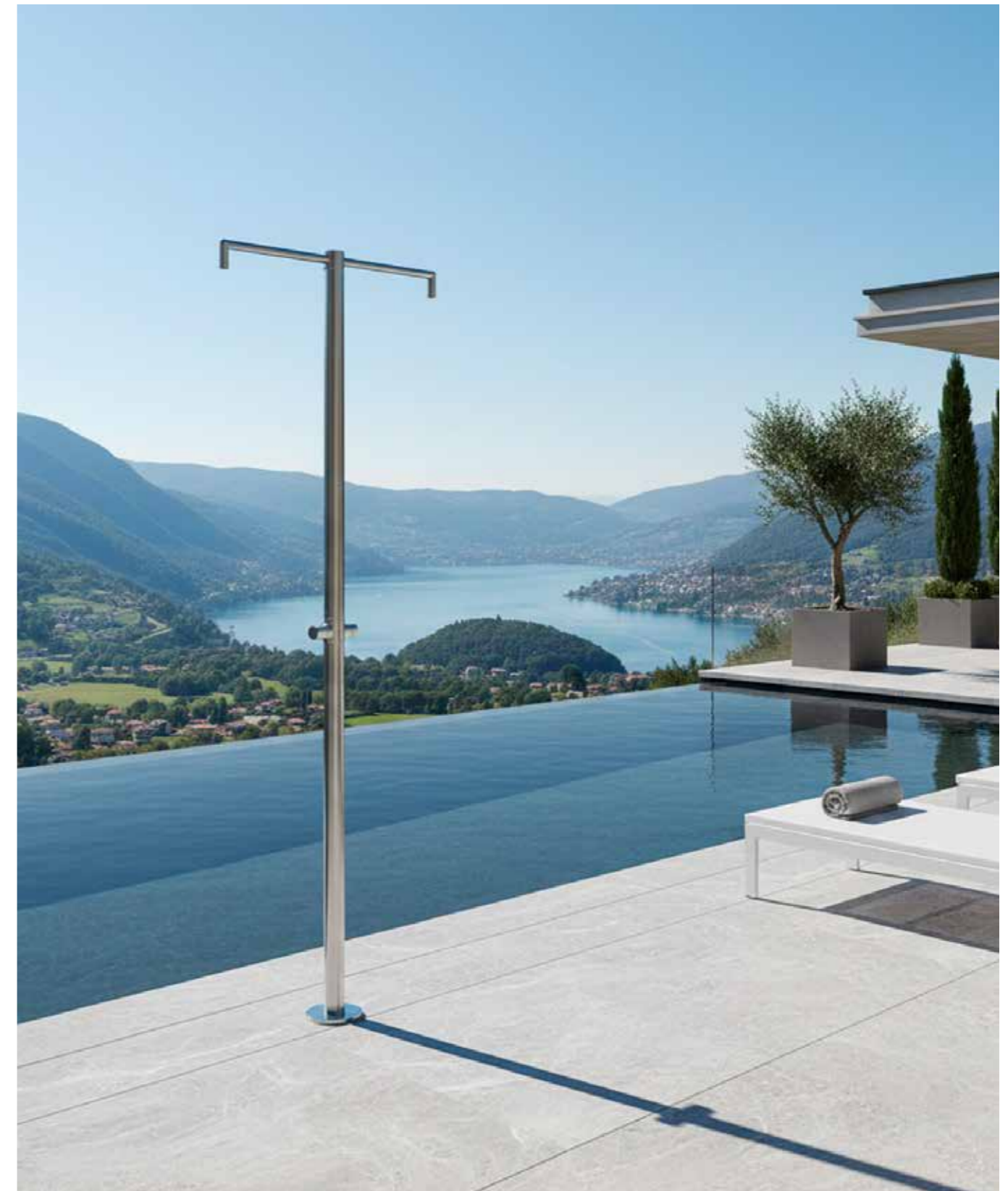
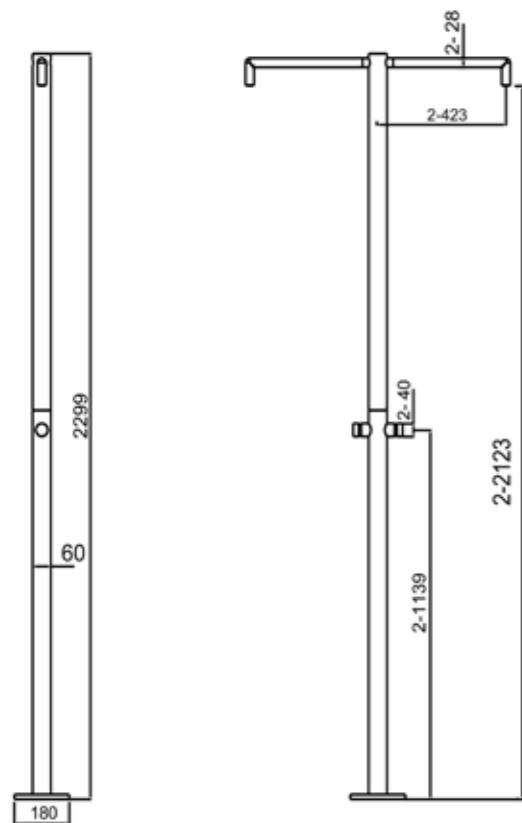

RUBINETTI ACCIAIO INOX 316L TAPS AND FAUCETS 316L STAINLESS STEEL

Presentiamo la nostra nuova linea di rubinetteria di design per bagni e cucine, realizzata interamente in acciaio inox. Ogni pezzo riflette un perfetto equilibrio tra estetica contemporanea, innovazione tecnica e massima durata. Una proposta esclusiva per chi ricerca funzionalità, eleganza e qualità superiore in ogni dettaglio dei propri ambienti.

We are proud to introduce our new line of designer faucets for bathrooms and kitchens, crafted entirely from stainless steel. Each piece embodies the perfect balance of contemporary aesthetics, technical innovation, and exceptional durability. An exclusive offering for those who seek functionality, elegance, and superior quality in every detail of their spaces.



RUBINETTO LAVABO LEVANTE

Design contemporaneo, essenza senza tempo

Linee pure, proporzioni armoniose e finiture impeccabili: il miscelatore per lavabo Levante in acciaio inox è pensato per chi cerca l'eccellenza.

Realizzato in acciaio inox, unisce forza e raffinatezza in un unico gesto quotidiano.

La sua estetica elegante e moderna valorizza gli spazi bagno contemporanei, sia privati che professionali.

Ogni dettaglio è stato curato per offrire comfort, durata e bellezza nel tempo.

Contemporary design, timeless essence

Pure lines, harmonious proportions and impeccable finishes: the Levante stainless steel basin mixer tap is designed for those who seek excellence.

Made of stainless steel, it combines strength and sophistication in a single everyday gesture.

Its sleek, modern aesthetic enhances contemporary bathroom spaces, both private and professional.

Every detail has been taken care of to offer comfort, durability and beauty over time.



RUBINETTO-LAVABO-LEVANTE-ALTO





STOCK

 **INOX** 8025431155671

PVD  **CANNA-FUCILE** 8025431158856

PVD  **ORO-ROSA** 8025431155671

PVD  **NERO** 8025431158863 *

PVD  **ORO** 8025431158870 *

*DISPONIBILE SOLO SU ORDINAZIONE

*AVAILABLE ONLY UPON REQUEST

CARATTERISTICHE

- **MATERIALE ACCIAIO INOX 316L / 316L STAINLESS STEEL**
- **MISCELATORE ALTO / TALL MIXER**
- **BECCUCCIO/SPOUT DA 19 CM, IDEAL FOR LAVELLI GRANDI/LARGER SINKS**
- **FLESSIBILI COLLEGAMENTO/STEELCONNECTION HOSES ACCIAIO INOX/STAINLESS STEEL ST/ST 304 DA 50CM**
- **AERATORE NEOPERL PER UN GETTO D'ACQUA DELICATO SENZA SPRUZZI / NEOPERL AERATOR FOR A GENTLE WATER JET WITHOUT SPLASHING**
- **CARTUCCIA/CARTRIDGE IN CERAMICA CERTIFICATA WANHAI**
CHIUSURA PERFETTA/ PERFECT CLOSE
NESSUNA PERDITA / NO LEAKING
RISPARMIO IDRICO / WATER SAVING
- **CHIAVI A BRUGOLA INCLUSE/ ALLEN KEYS INCLUDED**
- **ACQUA CALDA E FREDDA / WATER COLD AND HOT**
- **COMPLETAMENTE PRIVO DI PIOMBO/ LEAD-FREE**

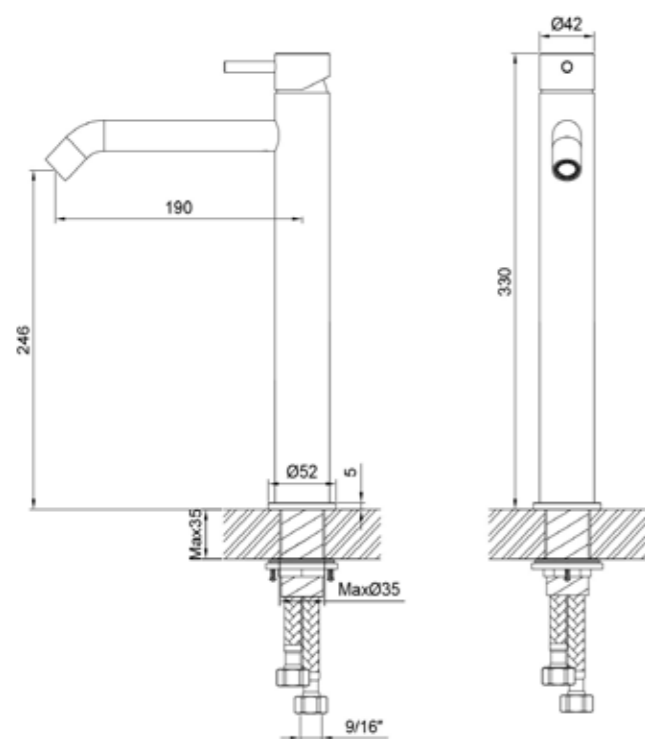

RUBINETTO-LAVABO-LEVANTE-BASSO



- STOCK
-  **INOX** 8025431155633
 - PVD  **CANNA-FUCILE** 8025431158887
 - PVD  **ORO-ROSA** 8025431156326
 - PVD  **NERA** 8025431158894 *
 - PVD  **ORO** 8025431158900 *

*DISPONIBILE SOLO SU ORDINAZIONE
*AVAILABLE ONLY UPON REQUEST



CARATTERISTICHE

- **MATERIALE ACCIAIO INOX 316L / 316L STAINLESS STEEL**
- **MISCELATORE BASSO / MIXER**
- **BECCUCCIO/SPOUT DA 12 CM, IDEAL FOR LAVELLI GRANDI/LARGER SINKS**
- **FLESSIBILI COLLEGAMENTO/STEELCONNECTION HOSES ACCIAIO INOX/STAINLESS STEEL ST/ST 304 DA 50CM**
- **AERATORE NEOPERL PER UN GETTO D'ACQUA DELICATO SENZA SPRUZZI / NEOPERL AERATOR FOR A GENTLE WATER JET WITHOUT SPLASHING**
- **CARTUCCIA/CARTRIDGE IN CERAMICA CERTIFICATA WANHAI**
CHIUSURA PERFETTA/ PERFECT CLOSE
NESSUNA PERDITA / NO LEAKING
RISPARMIO IDRICO / WATER SAVING
- **CHIAVI A BRUGOLA INCLUSE/ ALLEN KEYS INCLUDED**
- **ACQUA CALDA E FREDDA / WATER COLD AND HOT**
- **COMPLETAMENTE PRIVO DI PIOMBO/ LEAD-FREE**

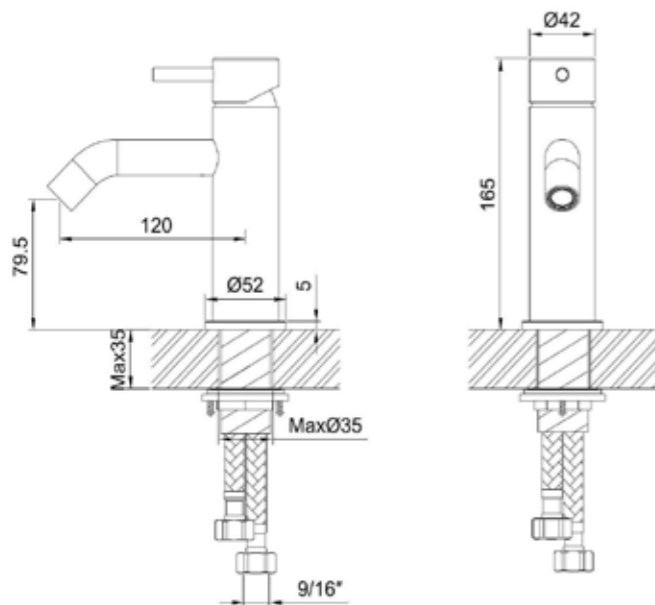

RUBINETTO-BIDET-LEVANTE

STOCK



 **INOX** 8025431155640

PVD  **CANNA-FUCILE** 8025431158825

PVD  **ORO-ROSA** 8025431156333

PVD  **NERO** 8025431158832 *

PVD  **ORO** 8025431158849 *

*DISPONIBILE SOLO SU ORDINAZIONE
*AVAILABLE ONLY UPON REQUEST



CARATTERISTICHE

- **MATERIALE ACCIAIO INOX 316L / 316L STAINLESS STEEL**
- **MISCELATORE BIDET / BIDET MIXER**
- **BECCUCCIO/SPOUT ROTABLE**
- **FLESSIBILI COLLEGAMENTO/STEELCONNECTION HOSES ACCIAIO INOX/STAINLESS STEEL ST/ST 304 DA 50CM**
- **AERATORE NEOPERL PER UN GETTO D'ACQUA DELICATO SENZA SPRUZZI / NEOPERL AERATOR FOR A GENTLE WATER JET WITHOUT SPLASHING**
- **GETTO D'ACQUA A GETTO/RAIN JET SPRAY**
- **CARTUCCIA/CARTRIDGE IN CERAMICA CERTIFICATA WANHAI**
CHIUSURA PERFETTA/ PERFECT CLOSE
NESSUNA PERDITA / NO LEAKING
RISPARMIO IDRICO / WATER SAVING
- **CHIAVI A BRUGOLA INCLUSE/ ALLEN KEYS INCLUDED**
- **ACQUA CALDA E FREDDA / WATER COLD AND HOT**
- **COMPLETAMENTE PRIVO DI PIOMBO/ LEAD-FREE**

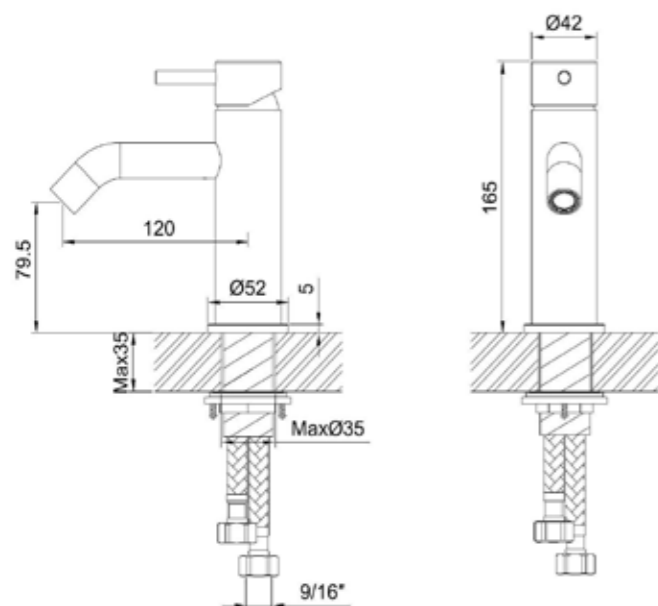

RUBINETTO LAVELLO LEVANTE

Eleganza funzionale per cucine di classe

La collezione Levante, nelle varianti alta e bassa, rappresenta l'equilibrio perfetto tra estetica e praticità.

Con un design moderno e linee essenziali, i Rubinetti Miscelatori Lavandino Inox Levante sono pensati per ambienti contemporanei, privati e professionali.

Realizzati in acciaio inox di alta qualità, garantiscono resistenza, igiene e lunga durata.

La versione alta offre una presenza slanciata e scenografica, mentre quella bassa si distingue per discrezione ed efficienza.

Due soluzioni, un'unica firma: SINED. Per chi sceglie un investimento durevole e di stile.

Functional elegance for refined kitchen spaces

The Levante collection, available in both tall and low versions, embodies the perfect balance of aesthetics and functionality.

With a modern design and clean lines, the Levante Stainless Steel Sink Mixers are crafted for contemporary spaces, both residential and professional.

Made from high-quality stainless steel, they ensure durability, hygiene, and lasting performance.

The tall version makes a bold, sculptural statement, while the low one offers subtlety and efficiency.

Two solutions, one signature: SINED. For those who value a stylish and lasting investment.



RUBINETTO-LAVELLO-LEVANTE-ALTO





STOCK

 **INOX** 8025431155657

PVD  **CANNA-FUCILE** 8025431158917

PVD  **ORO-ROSA** 8025431156357

PVD  **NERA** 8025431158924 *

PVD  **ORO** 8025431158931 *

*DISPONIBILE SOLO SU ORDINAZIONE

*AVAILABLE ONLY UPON REQUEST

CARATTERISTICHE

- **MATERIALE ACCIAIO INOX 316L / 316L STAINLESS STEEL**
- **BOCCA GIREVOLE 360° / SWIVEL SPOUT 360°**
- **CARTUCCIA IN CERAMICA CERTIFICATA WANHAI CERTIFIED WANHAI CERAMIC CARTRIDGE**
CONTROLLO FLUIDO - NESSUNA PERDITA
SMOOTH CONTROL - NO LEAKING
- **AERATORE NEOPERL PER UN GETTO D'ACQUA DELICATO SENZA SPRUZZI / NEOPERL AERATOR FOR A GENTLE WATER JET WITHOUT SPLASHING**
- **ACQUA CALDA E FREDDA / COLD AND HOT WATER** 
- **FLESSIBILI DA 50 CM IN ACCIAIO INOX INCLUSI / 50CM FLEXIBLE STAINLESS STEEL HOSES INCLUDED**
- **CHIAVI A BRUGOLA INCLUSE/ ALLEN KEYS INCLUDED**
- **CHIAVE DI SERVIZIO PER AERATORE INCLUSA / AERATOR SERVICE KEY INCLUDED**
- **COMPLETAMENTE PRIVO DI PIOMBO/ LEAD-FREE**

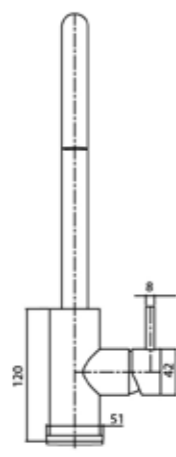
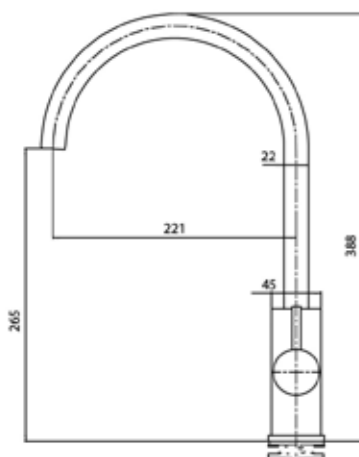

RUBINETTO-LAVELLO-LEVANTE-BASSO





STOCK

 **INOX** 8025431155664

PVD  **CANNA-FUCILE** 8025431158948

PVD  **ORO-ROSA** 8025431156364

PVD  **NERO** 8025431158955 *

PVD  **ORO** 8025431158962 *

*DISPONIBILE SOLO SU ORDINAZIONE
*AVAILABLE ONLY UPON REQUEST

CARATTERISTICHE

- **MATERIALE ACCIAIO INOX 316L / 316L STAINLESS STEEL**
- **BOCCA GIREVOLE 360° / SWIVEL SPOUT 360°**
- **CARTUCCIA IN CERAMICA CERTIFICATA WANHAI / CERTIFIED WANHAI CERAMIC CARTRIDGE**
CONTROLLO FLUIDO - NESSUNA PERDITA
SMOOTH CONTROL - NO LEAKING
- **AERATORE NEOPERL PER UN GETTO D'ACQUA DELICATO SENZA SPRUZZI / NEOPERL AERATOR FOR A GENTLE WATER JET WITHOUT SPLASHING**
- **ACQUA CALDA E FREDDA / COLD AND HOT WATER** 
- **FLESSIBILI DA 50 CM IN ACCIAIO INOX INCLUSI / 50CM FLEXIBLE STAINLESS STEEL HOSES INCLUDED**
- **CHIAVI A BRUGOLA INCLUSE / ALLEN KEYS INCLUDED**
- **CHIAVE DI SERVIZIO PER AERATORE INCLUSA / AERATOR SERVICE KEY INCLUDED**
- **COMPLETAMENTE PRIVO DI PIOMBO / LEAD-FREE**

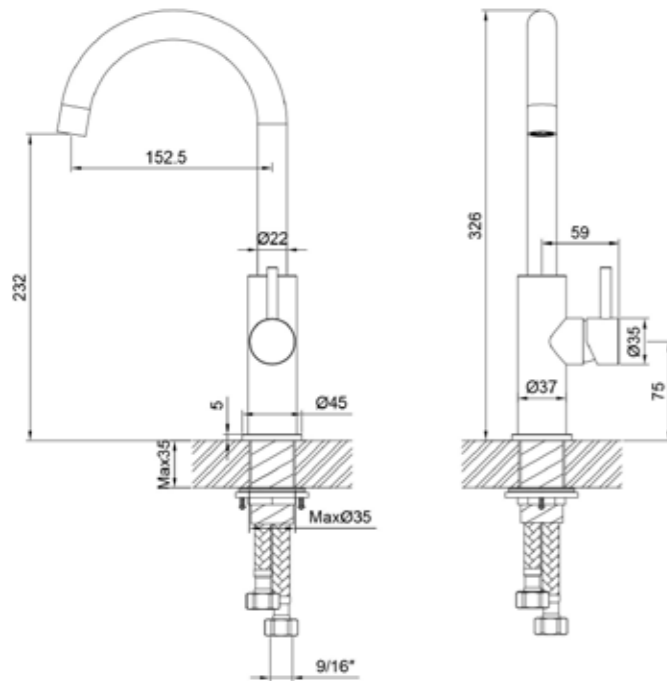

RUBINETTO-LAVELLO-LEVANTE-QUADRO

STOCK



 **INOX** 8025431159112

PVD  **CANNA-FUCILE** 8025431159105

PVD  **ORO-ROSA** 8025431159143

PVD  **NERO** 8025431159129 *

PVD  **ORO** 8025431159136 *

*DISPONIBILE SOLO SU ORDINAZIONE
*AVAILABLE ONLY UPON REQUEST



CARATTERISTICHE

- **MATERIALE ACCIAIO INOX 316L / 316L STAINLESS STEEL**
- **BOCCA GIREVOLE 360° / SWIVEL SPOUT 360°**
- **CARTUCCIA IN CERAMICA CERTIFICATA WANHAI / CERTIFIED WANHAI CERAMIC CARTRIDGE**
CONTROLLO FLUIDO - NESSUNA PERDITA
SMOOTH CONTROL - NO LEAKING
- **AERATORE NEOPERL PER UN GETTO D'ACQUA DELICATO SENZA SPRUZZI / NEOPERL AERATOR FOR A GENTLE WATER JET WITHOUT SPLASHING**
- **ACQUA CALDA E FREDDA / COLD AND HOT WATER** 
- **FLESSIBILI DA 45 CM IN ACCIAIO INOX INCLUSI / 45CM FLEXIBLE STAINLESS STEEL HOSES INCLUDED**
- **CHIAVI A BRUGOLA INCLUSE / ALLEN KEYS INCLUDED**
- **CHIAVE DI SERVIZIO PER AERATORE INCLUSA / AERATOR SERVICE KEY INCLUDED**
- **COMPLETAMENTE PRIVO DI PIOMBO / LEAD-FREE**

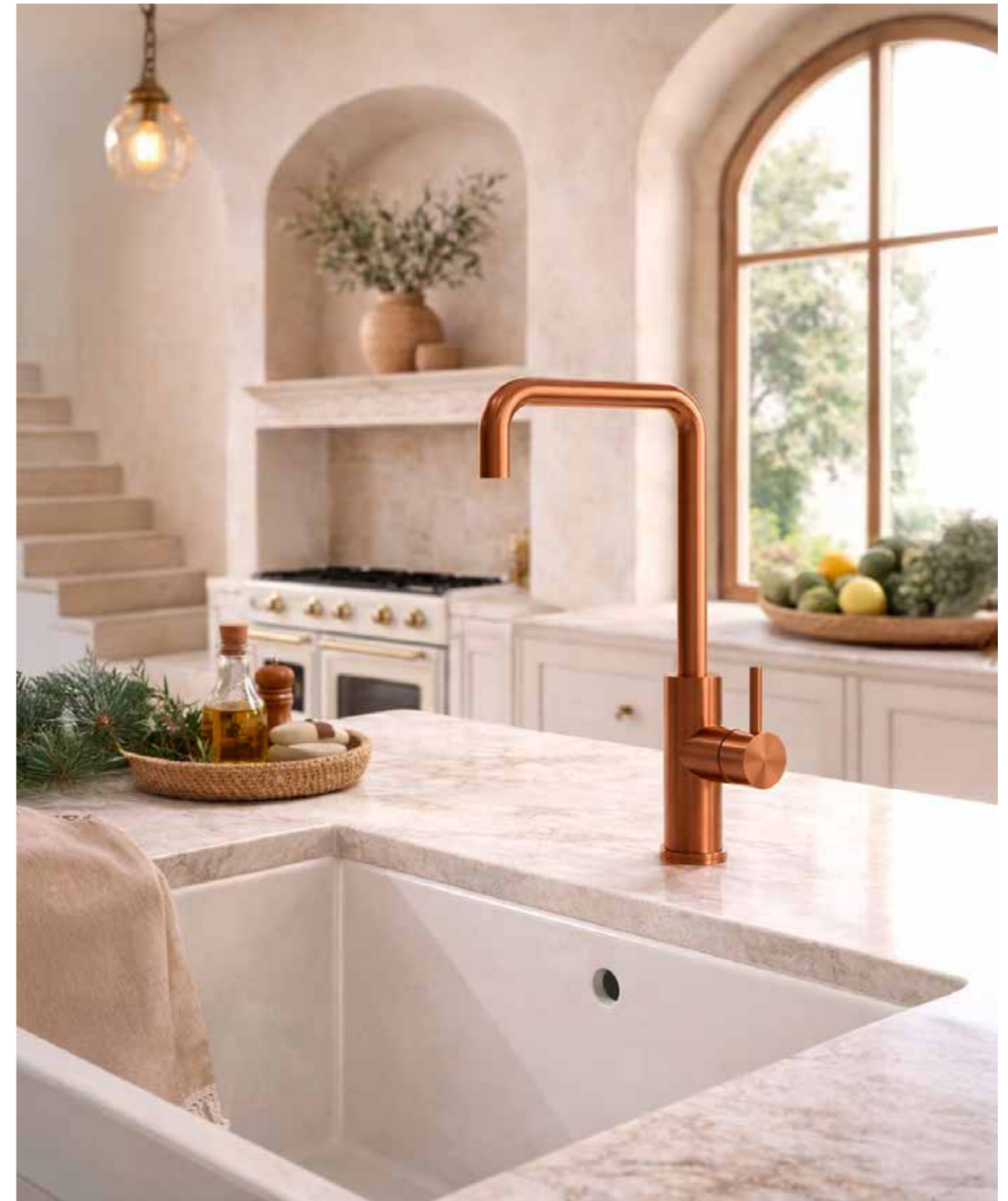
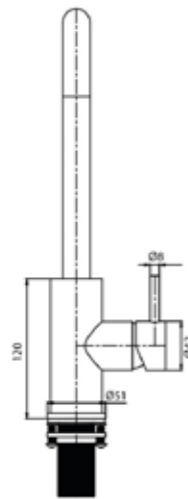
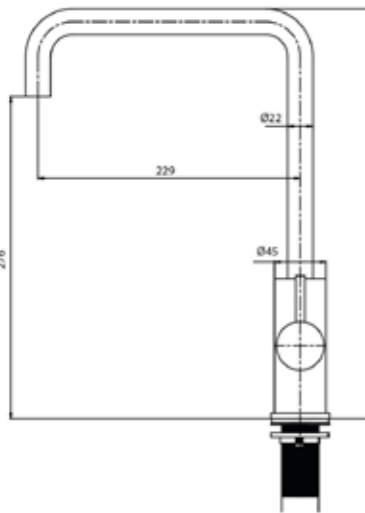

RUBINETTO-LAVELLO-LEVANTE-ESTRAIBILE

STOCK



 **INOX** 8025431159167

PVD  **CANNA-FUCILE** 8025431159150

PVD  **ORO-ROSA** 8025431159198

PVD  **NERO** 8025431159174 *

PVD  **ORO** 8025431159181 *

*DISPONIBILE SOLO SU ORDINAZIONE
*AVAILABLE ONLY UPON REQUEST

CARATTERISTICHE

- **MATERIALE ACCIAIO INOX 316L / 316L STAINLESS STEEL**
- **BOCCA GIREVOLE 360° / SWIVEL SPOUT 360°**
- **CARTUCCIA IN CERAMICA CERTIFICATA WANHAI
CERTIFIED WANHAI CERAMIC CARTRIDGE**
CONTROLLO FLUIDO - NESSUNA PERDITA
SMOOTH CONTROL - NO LEAKING
- **AERATORE NEOPERL PER UN GETTO D'ACQUA
DELICATO SENZA SPRUZZI / NEOPERL AERATOR
FOR A GENTLE WATER JET WITHOUT SPLASHING**
- **ACQUA CALDA E FREDDA / COLD AND HOT WATER** 
- **FLESSIBILI DA 50 CM IN ACCIAIO INOX INCLUSI
50CM FLEXIBLE STAINLESS STEEL HOSES
INCLUDED**
- **CHIAVI A BRUGOLA INCLUSE/ ALLEN KEYS
INCLUDED**
- **CHIAVE DI SERVIZIO PER AERATORE INCLUSA
AERATOR SERVICE KEY INCLUDED**
- **COMPLETAMENTE PRIVO DI PIOMBO/ LEAD-FREE**

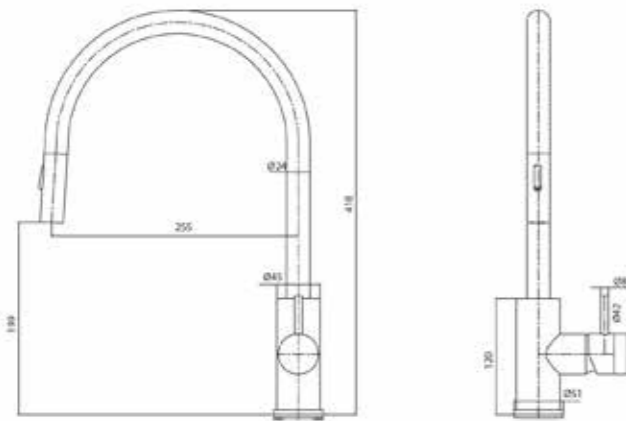

RUBINETTERIA DA PARETE WALL-MOUNTED TAPS

Pareti che ispirano design

Una sintesi perfetta tra forma e funzione.

La collezione di miscelatori a parete nasce per chi vive il design come estensione dell'architettura.

Linee pure, volumi bilanciati e proporzioni precise definiscono ogni elemento.

L'acciaio inossidabile AISI 316L dona carattere, resistenza e raffinatezza al tatto.

L'installazione a incasso libera lo spazio visivo, creando superfici continue ed essenziali.

Ogni dettaglio è pensato per dialogare con la luce, l'acqua e la materia.

Ideale per ambienti contemporanei dove il dettaglio fa la differenza.

Una proposta estetica e funzionale che trasforma l'ordinario in straordinario.

Walls that inspire design

A perfect synthesis of form and function.

The wall-mounted mixer collection is created for those who see design as an extension of architecture.

Pure lines, balanced volumes, and precise proportions define each element.

AISI 316L stainless steel brings character, durability, and a refined tactile feel.

Concealed installation frees the visual space, creating clean and continuous surfaces.

Every detail is designed to interact with light, water, and material.

Ideal for contemporary spaces where detail makes the difference.

An aesthetic and functional statement that turns the everyday into the exceptional.

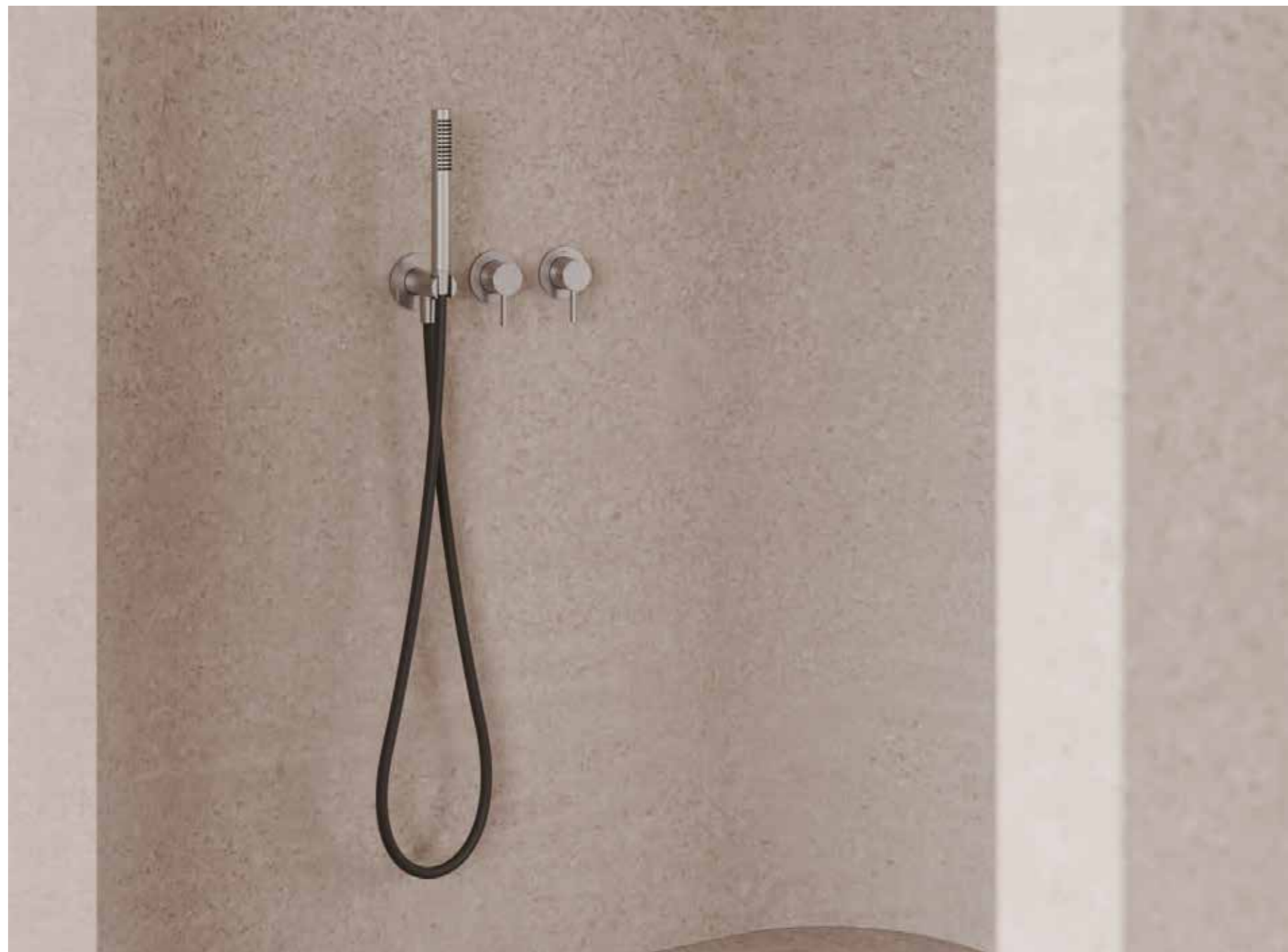

MISCELATORE-MURO-LEVANTE



STOCK

 INOX 8025431155862

PVD  ORO-ROSA 8025431156302

PVD  CANNA-FUCILE 8025431159495



CARATTERISTICHE

- **MATERIALE ACCIAIO INOX 316L / 316L STAINLESS STEEL**
- **MISCELATORE A PARETE / WALL MIXER**
- **INSTALLAZIONE A INCASSO
CONCEALED INSTALLATION**
- **PARTICOLARMENTE ADATTO PER AMBIENTI AD ALTO UTILIZZO O IN PROSSIMITÀ DEL MARE
PARTICULARLY SUITABLE FOR HIGH-USE ENVIRONMENTS AND COASTAL AREAS**
- **CORPO INCASSO INCLUSO
WALL RECESSED BODY INCLUDED**
- **CARTUCCIA CERAMICA WANHAI
WANHAI CERAMIC CARTRIDGE**
- **IDEALE PER STRUTTURE COME HOTEL, PISCINE PUBBLICHE, PALESTRE, AEROPORTI O BAGNI DI LOCALI CHE RICEVONO UN GRANDE FLUSSO DI UTENTI OGNI GIORNO
IDEAL FOR FACILITIES SUCH AS HOTELS, PUBLIC POOLS, GYMS, AIRPORTS, AND HIGH-TRAFFIC RESTROOMS EXPERIENCE CONSTANT DAILY USE**

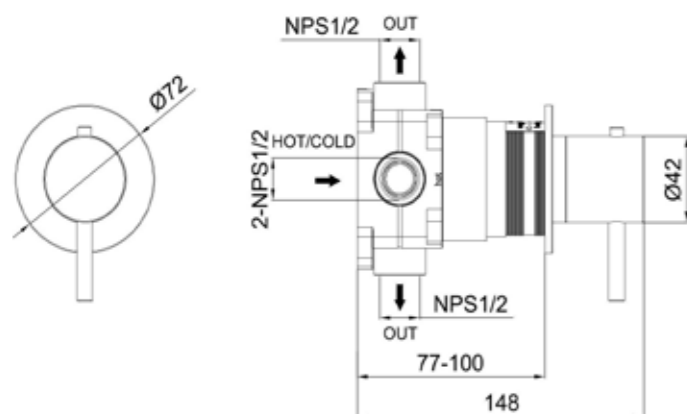

MISCELATORE-MURO-LEVANTE-TERMOSTATICO



STOCK

 INOX 8025431155930

PVD  ORO-ROSA 8025431156265

PVD  CANNA-FUCILE 8025431159501

CARATTERISTICHE

- **MATERIALE ACCIAIO INOX 316L / 316L STAINLESS STEEL**
- **MISCELATORE TERMOSTATICO A PARETE / WALL THERMOSTATIC MIXER**
- **INSTALLAZIONE A INCASSO
CONCEALED INSTALLATION**
- **PARTICOLARMENTE ADATTO PER AMBIENTI AD ALTO UTILIZZO O IN PROSSIMITÀ DEL MARE
PARTICULARLY SUITABLE FOR HIGH-USE ENVIRONMENTS AND COASTAL AREAS**
- **CORPO INCASSO INCLUSO
WALL RECESSED BODY INCLUDED**
- **SPECIALE CARTUCCIA TERMOSTATICA DESIGN PROPRIETARIO / SPECIAL PROPRIETARY THERMOSTATIC CARTRIDGE DESIGN**
- **IDEALE PER STRUTTURE COME HOTEL, PISCINE PUBBLICHE, PALESTRE, AEROPORTI O BAGNI DI LOCALI CHE RICEVONO UN GRANDE FLUSSO DI UTENTI OGNI GIORNO
IDEAL FOR FACILITIES SUCH AS HOTELS, PUBLIC POOLS, GYMS, AIRPORTS, AND HIGH-TRAFFIC RESTROOMS EXPERIENCE CONSTANT DAILY USE**

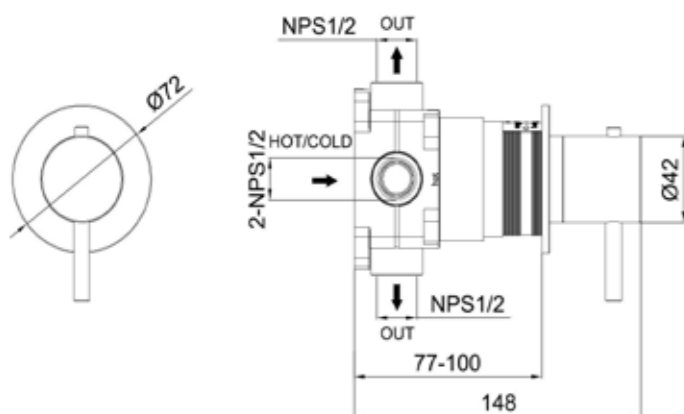

MISCELATORE-MURO-DOCCIA-LEVANTE

STOCK



 **INOX** 8025431155879

PVD  **ORO-ROSA** 8025431156289

PVD  **CANNA-FUCILE** 8025431159471



CARATTERISTICHE

- **MATERIALE ACCIAIO INOX 316L / 316L STAINLESS STEEL**
- **INSTALLAZIONE A INCASSO
CONCEALED INSTALLATION**
- **PARTICOLARMENTE ADATTO PER AMBIENTI AD ALTO UTILIZZO O IN PROSSIMITÀ DEL MARE
PARTICULARLY SUITABLE FOR HIGH-USE ENVIRONMENTS AND COASTAL AREAS**
- **MISCELATORE DOCCIA A MURO
WALL-MOUNTED SHOWER MIXER**
- **COMANDO MONOLEVA
SINGLE LEVER CONTROL**
- **CONTROLLO PRECISO DI FLUSSO E TEMPERATURA
PRECISE FLOW AND TEMPERATURE CONTROL**
- **ADATTO PER USO INTERNO ED ESTERNO
SUITABLE FOR INDOOR AND OUTDOOR USE**
- **INTERASSE DI FISSAGGIO 15 CM
15 CM FIXING DISTANCE (CENTER-TO-CENTER)**
- **ATTACCO A MURO ASIMMETRICO PER REGOLAZIONE IN FASE DI INSTALLAZIONE
ASYMMETRIC WALL FIXING FOR INSTALLATION ADJUSTMENT**
- **INGRESSO ACQUA CALDA A DESTRA
HOT WATER INLET ON THE RIGHT**

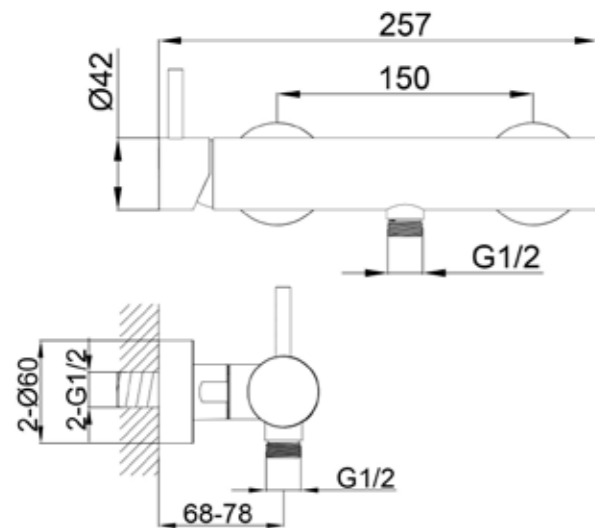

MISCELATORE-TERMOSTATICO-LEVANTE

STOCK



INOX 8025431155886

PVD ORO-ROSA 8025431158993

PVD CANNA-FUCILE 8025431159518



CARATTERISTICHE

- **MATERIALE ACCIAIO INOX 316L / 316L STAINLESS STEEL**
- **MISCELATORE TERMOSTATICO DOCCIA A MURO**
WALL-MOUNTED THERMOSTATIC SHOWER MIXER
- **INSTALLAZIONE A INCASSO**
CONCEALED INSTALLATION
- **PARTICOLARMENTE ADATTO PER AMBIENTI AD ALTO UTILIZZO O IN PROSSIMITÀ DEL MARE**
PARTICULARLY SUITABLE FOR HIGH-USE ENVIRONMENTS AND COASTAL AERAS
- **COMANDO DOPPIA LEVA**
DOUBLE LEVER CONTROL
- **CONTROLLO PRECISO DI FLUSSO E TEMPERATURA**
PRECISE FLOW AND TEMPERATURE CONTROL
- **ADATTO PER USO INTERNO ED ESTERNO**
SUITABLE FOR INDOOR AND OUTDOOR USE
- **SPECIALE CARTUCCIA TERMOSTATICA DESIGN PROPRIETARIO / SPECIAL PROPRIETARY THERMOSTATIC CARTRIDGE DESIGN**
- **INTERASSE DI FISSAGGIO 15 CM**
15 CM FIXING DISTANCE (CENTER-TO-CENTER)
- **ATTACCO A MURO ASIMMETRICO PER REGOLAZIONE IN FASE DI INSTALLAZIONE**
ASYMMETRIC WALL FIXING FOR INSTALLATION ADJUSTMENT
- **INGRESSO ACQUA CALDA A DESTRA**
HOT WATER INLET ON THE RIGHT

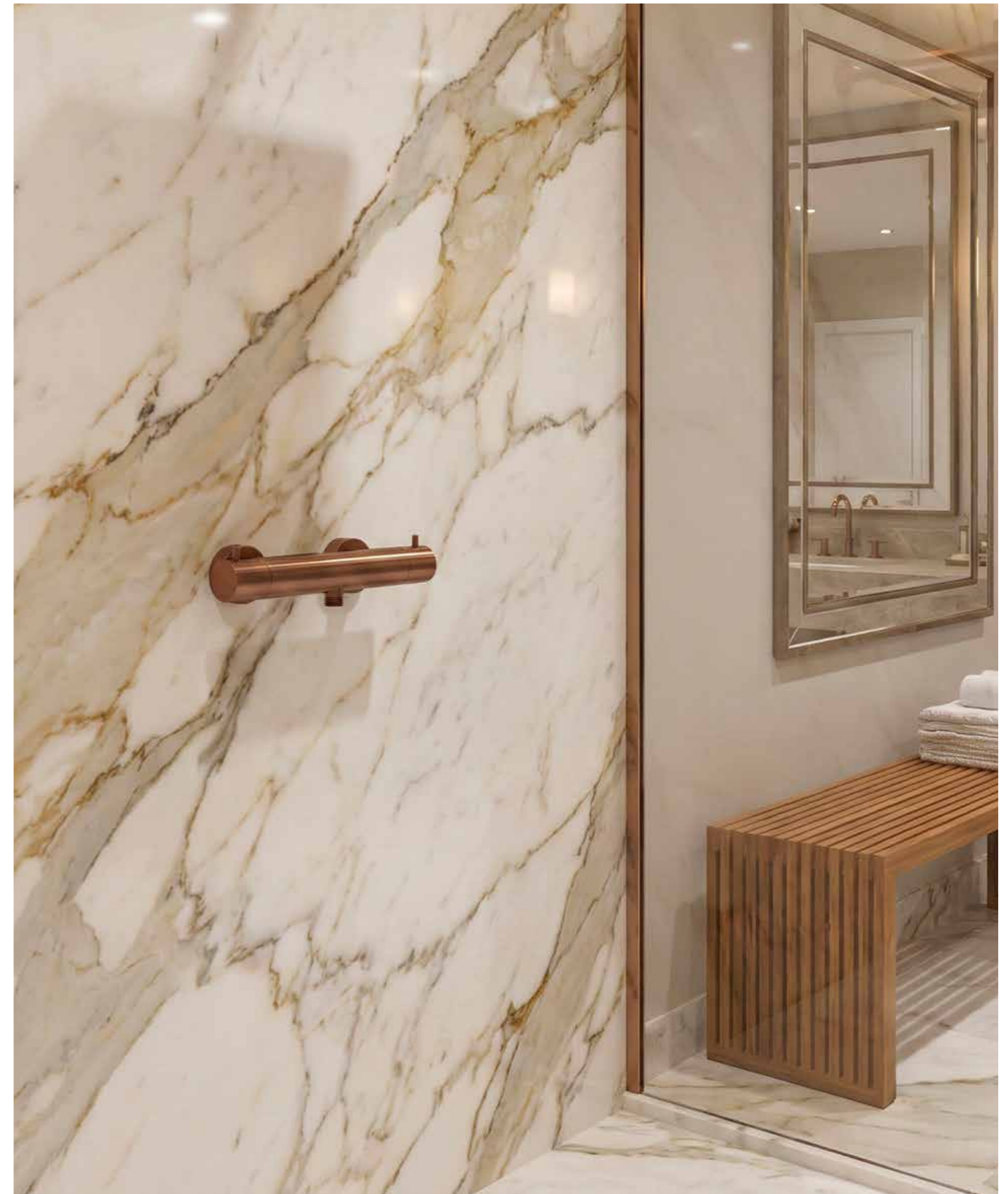
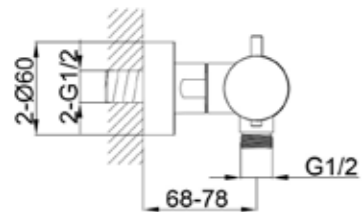
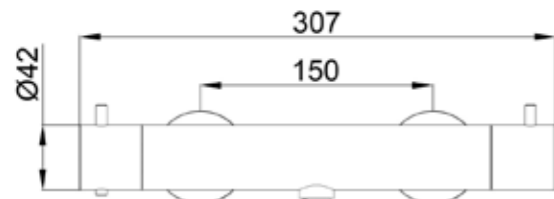

MISCELATORE-MURO-DOCCIA-VASCA-LEVANTE

STOCK



INOX 8025431155893

PVD ORO-ROSA 8025431156296

PVD CANNA-FUCILE 8025431159488



CARATTERISTICHE

- **MATERIALE ACCIAIO INOX 316L / 316L STAINLESS STEEL**
- **INSTALLAZIONE A INCASSO**
CONCEALED INSTALLATION
- **PARTICOLARMENTE ADATTO PER AMBIENTI AD ALTO UTILIZZO O IN PROSSIMITÀ DEL MARE**
PARTICULARLY SUITABLE FOR HIGH-USE ENVIRONMENTS AND COASTAL AREAS
- **MISCELATORE DOCCIA-VASCA A MURO**
WALL-MOUNTED SHOWER-BATH MIXER
- **COMANDO DOPPIA LEVA**
DOUBLE LEVER CONTROL
- **CONTROLLO PRECISO DI FLUSSO E TEMPERATURA**
PRECISE FLOW AND TEMPERATURE CONTROL
- **ADATTO PER USO INTERNO ED ESTERNO**
SUITABLE FOR INDOOR AND OUTDOOR USE
- **INTERASSE DI FISSAGGIO 15 CM**
15 CM FIXING DISTANCE (CENTER-TO-CENTER)
- **ATTACCO A MURO ASIMMETRICO PER REGOLAZIONE IN FASE DI INSTALLAZIONE**
ASYMMETRIC WALL FIXING FOR INSTALLATION ADJUSTMENT
- **INGRESSO ACQUA CALDA A DESTRA**
HOT WATER INLET ON THE RIGHT

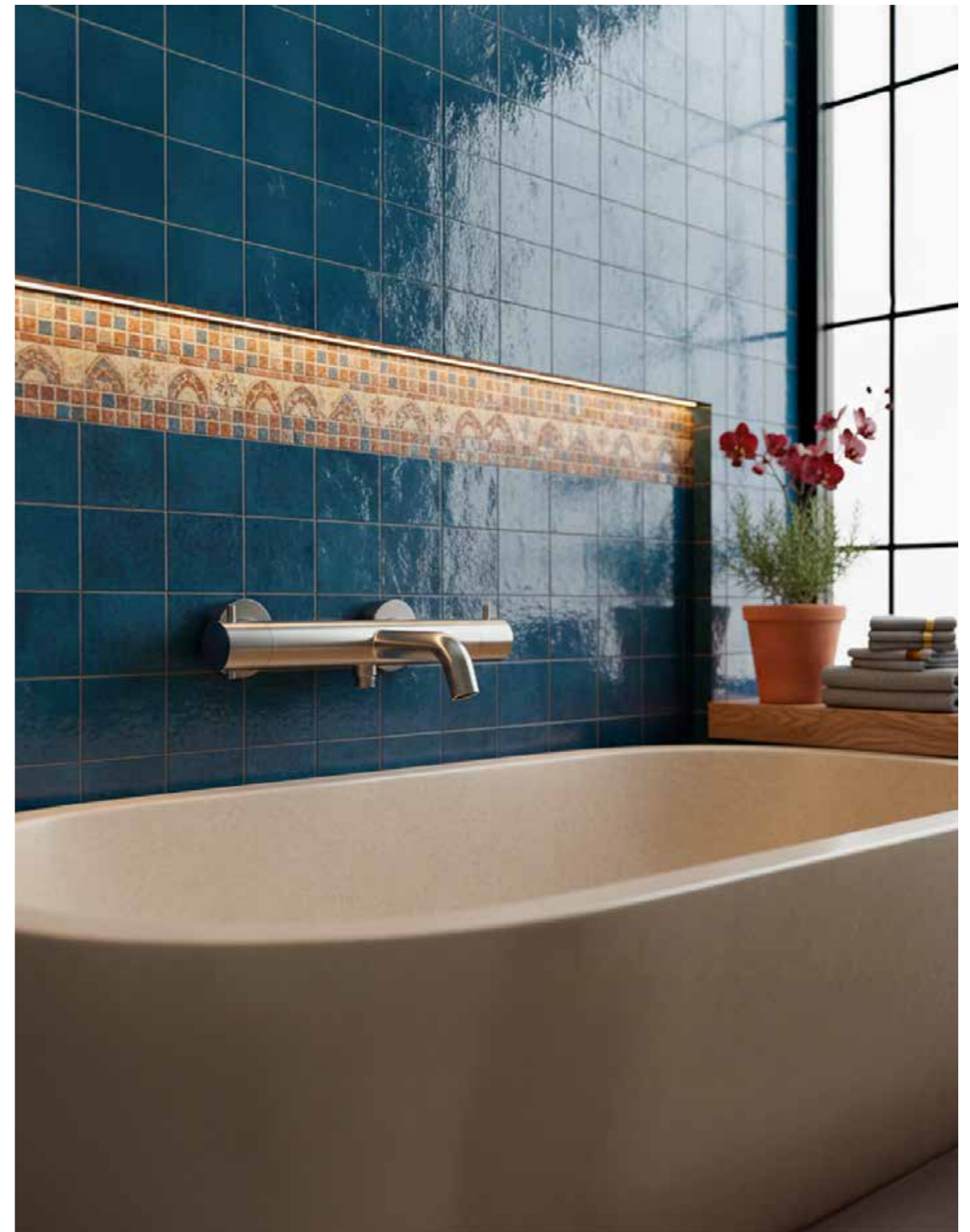
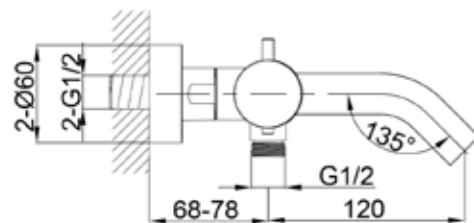
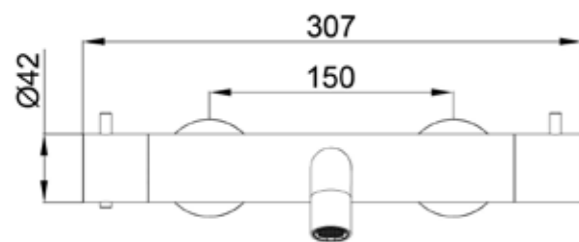

MISCELATORE-MURO-ATTACCO-DOCCINO-LEVANTE

STOCK



 **INOX** 8025431155855

PVD  **CANNA-FUCILE** 8025431158436

PVD  **ORO-ROSA** 8025431156272

PVD  **NERO** 8025431158429 *

PVD  **ORO** 8025431158412 *

*DISPONIBILE SOLO SU ORDINAZIONE
*AVAILABLE ONLY UPON REQUEST

CARATTERISTICHE

- **MATERIALE ACCIAIO INOX 316L / 316L STAINLESS STEEL**
- **MISCELATORE A MURO CON ATTACCO DOCCINO**
WALL-MOUNTED MIXER WITH HAND SHOWER CONNECTION
- **INSTALLAZIONE A INCASSO CON BOX NASCOSTO**
CONCEALED INSTALLATION WITH HIDDEN BOX
- **CORPO INCASSO INCLUSO**
WALL RECESSED BODY INCLUDED
- **COMPLETAMENTE PRIVO DI PIOMBO**
COMPLETELY LEAD-FREE
- **COMPATIBILE CON FLESSIBILI STANDARD 1/2"**
COMPATIBLE WITH STANDARD FLEXIBLE HOSES 1/2"

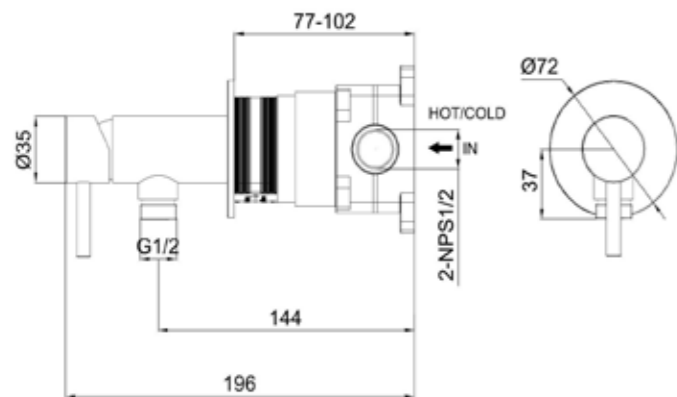

DEVIATORE-MURO-LEVANTE

STOCK



 INOX 8025431156180

PVD  ORO-ROSA 8025431156197

PVD  CANNA-FUCILE 8025431159327



CARATTERISTICHE

- **MATERIALE ACCIAIO INOX 316L / 316L STAINLESS STEEL**
- **INSTALLAZIONE A INCASSO
CONCEALED INSTALLATION**
- **PARTICOLARMENTE ADATTO PER AMBIENTI AD ALTO UTILIZZO O IN PROSSIMITÀ DEL MARE
PARTICULARLY SUITABLE FOR HIGH-USE ENVIRONMENTS AND COASTAL AERAS**
- **MISCELATORE DIVER / DIVER MIXER**
- **CORPO INCASSO INCLUSO
WALL RECESSED BODY INCLUDED**
- **IDEALE PER STRUTTURE COME HOTEL, PISCINE PUBBLICHE, PALESTRE, AEROPORTI O BAGNI DI LOCALI CHE RICEVONO UN GRANDE FLUSSO DI UTENTI OGNI GIORNO
IDEAL FOR FACILITIES SUCH AS HOTELS, PUBLIC POOLS, GYMS, AIRPORTS, AND HIGH-TRAFFIC RESTROOMS EXPERIENCE CONSTANT DAILY USE**

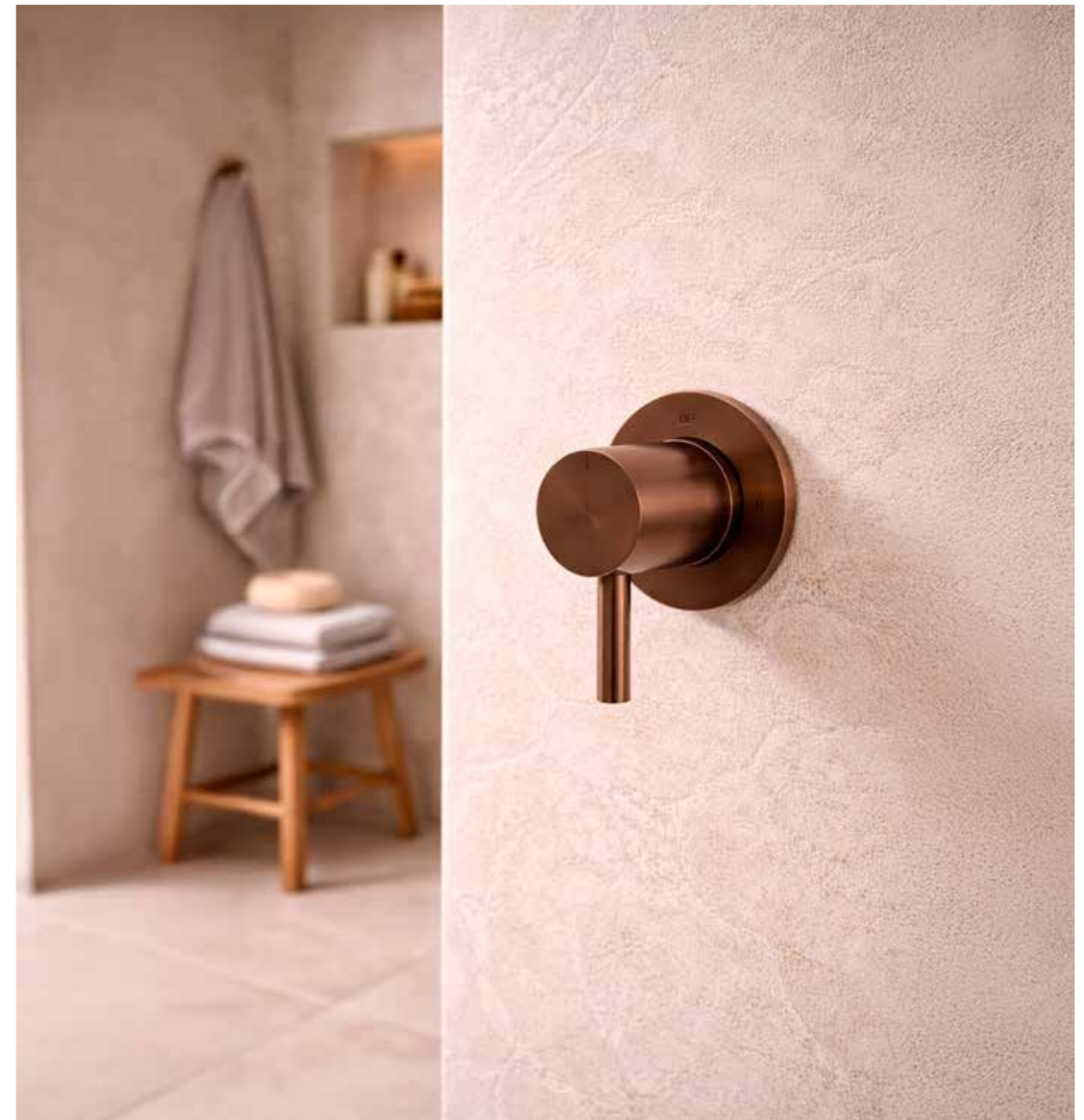
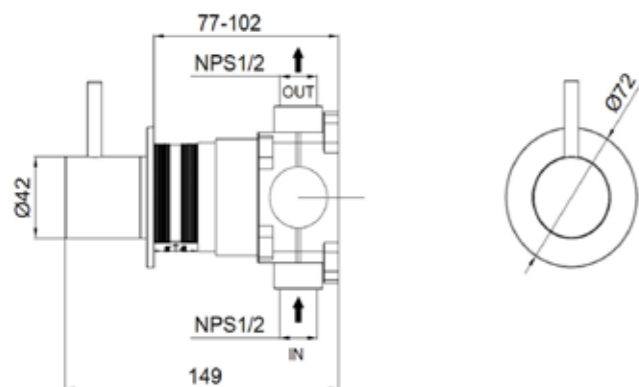

ATTACCO-MURO-DOCCINO-LEVANTE



STOCK

 **INOX** 8025431159075

PVD  **ORO-ROSA** 8025431159082

PVD  **CANNA-FUCILE** 8025431159310

CARATTERISTICHE

- **MATERIALE ACCIAIO INOX 316L / 316L STAINLESS STEEL**
- **ATTACCO ACQUA A PARETE PER DOCCINO**
WALL WATER OUTLET FOR HAND SHOWER
- **INSTALLAZIONE A MURO**
WALL-MOUNTED INSTALLATION
- **CONNESSIONE STANDARD**
STANDARD CONNECTION
- **COMPLETAMENTE PRIVO DI PIOMBO**
COMPLETELY LEAD-FREE
- **PARTICOLARMENTE ADATTO PER AMBIENTI AD ALTO UTILIZZO O IN PROSSIMITÀ DEL MARE**
PARTICULARLY SUITABLE FOR HIGH-USE ENVIRONMENTS AND COASTAL AREAS
- **IDEALE PER STRUTTURE COME HOTEL, PISCINE PUBBLICHE, PALESTRE, AEROPORTI O BAGNI DI LOCALI CHE RICEVONO UN GRANDE FLUSSO DI UTENTI OGNI GIORNO**
IDEAL FOR FACILITIES SUCH AS HOTELS, PUBLIC POOLS, GYMS, AIRPORTS, AND HIGH-TRAFFIC RESTROOMS EXPERIENCE CONSTANT DAILY USE

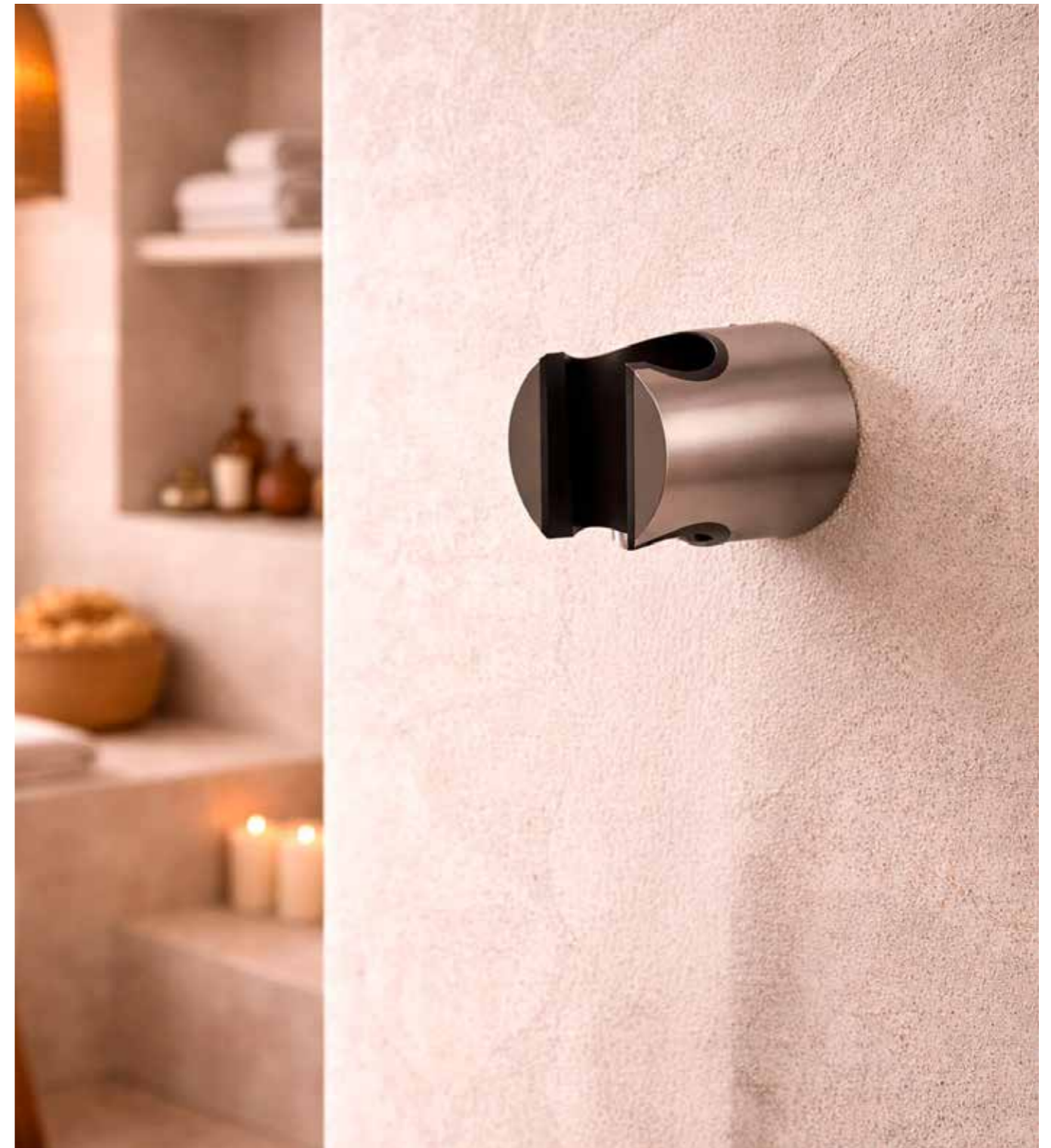
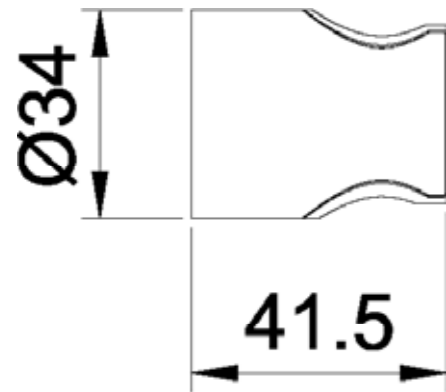

ATTACCO-DOCCINO-FLESSIBILE-WATER

STOCK



 **INOX** 8025431156807

PVD  **ORO-ROSA** 8025431156814

PVD  **CANNA-FUCILE** 8025431158672

PVD  **NERO** 8025431158689 *

PVD  **ORO** 8025431158696 *

*DISPONIBILE SOLO SU ORDINAZIONE
*AVAILABLE ONLY UPON REQUEST



CARATTERISTICHE

- **MATERIALE ACCIAIO INOX 316L / 316L STAINLESS STEEL**
- **ATTACCO DOCCINO FLESSIBILE A PARETE DA INCASSO**
WALL-MOUNTED BUILT-IN FLEXIBLE HAND SHOWER CONNECTION
- **INSTALLAZIONE A INCASSO CON BOX NASCOSTO**
CONCEALED INSTALLATION WITH HIDDEN BOX
- **CORPO INCASSO INCLUSO**
WALL RECESSED BODY INCLUDED
- **IDEALE PER COLLEGAMENTO DOCCINO BIDET**
IDEAL FOR FLEXIBLE BIDET HAND SHOWER CONNECTION
- **COMPATIBILE CON FLESSIBILI STANDARD 1/2"**
COMPATIBLE WITH STANDARD FLEXIBLE HOSES 1/2"
- **COMPLETAMENTE PRIVO DI PIOMBO**
COMPLETELY LEAD-FREE
- **PARTICOLARMENTE ADATTO PER AMBIENTI AD ALTO UTILIZZO O IN PROSSIMITÀ DEL MARE**
PARTICULARLY SUITABLE FOR HIGH-USE ENVIRONMENTS AND COASTAL AREAS
- **IDEALE PER STRUTTURE COME HOTEL, PISCINE PUBBLICHE, PALESTRE, AEROPORTI O BAGNI DI LOCALI CHE RICEVONO UN GRANDE FLUSSO DI UTENTI OGNI GIORNO**
IDEAL FOR FACILITIES SUCH AS HOTELS, PUBLIC POOLS, GYMS, AIRPORTS, AND HIGH-TRAFFIC RESTROOMS EXPERIENCE CONSTANT DAILY USE

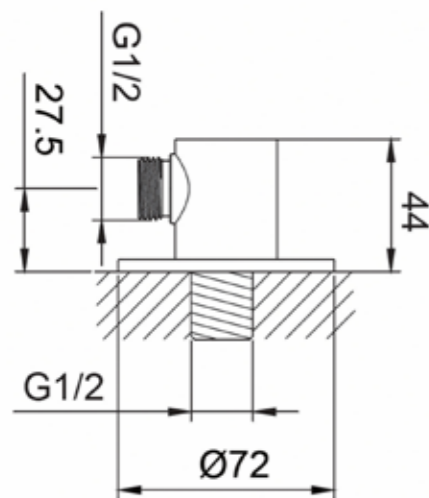

SUPPORTO-MURO-DOCCINO-LEVANTE



STOCK

 INOX 8025431159037

PVD  ORO-ROSA 8025431159044

PVD  CANNA-FUCILE 8025431159372

CARATTERISTICHE

- **MATERIALE ACCIAIO INOX 316L / 316L STAINLESS STEEL**
- **SUPPORTO DOCCINO A PARETE**
WALL-MOUNTED HAND SHOWER HOLDER
- **INSTALLAZIONE A MURO**
WALL INSTALLATION
- **COMPLETAMENTE PRIVO DI PIOMBO**
COMPLETELY LEAD-FREE
- **CORPO INCASSO INCLUSO**
WALL RECESSED BODY INCLUDED
- **PARTICOLARMENTE ADATTO PER AMBIENTI AD ALTO UTILIZZO O IN PROSSIMITÀ DEL MARE**
PARTICULARLY SUITABLE FOR HIGH-USE ENVIRONMENTS AND COASTAL AREAS
- **IDEALE PER STRUTTURE COME HOTEL, PISCINE PUBBLICHE, PALESTRE, AEROPORTI O BAGNI DI LOCALI CHE RICEVONO UN GRANDE FLUSSO DI UTENTI OGNI GIORNO**
IDEAL FOR FACILITIES SUCH AS HOTELS, PUBLIC POOLS, GYMS, AIRPORTS, AND HIGH-TRAFFIC RESTROOMS EXPERIENCE CONSTANT DAILY USE

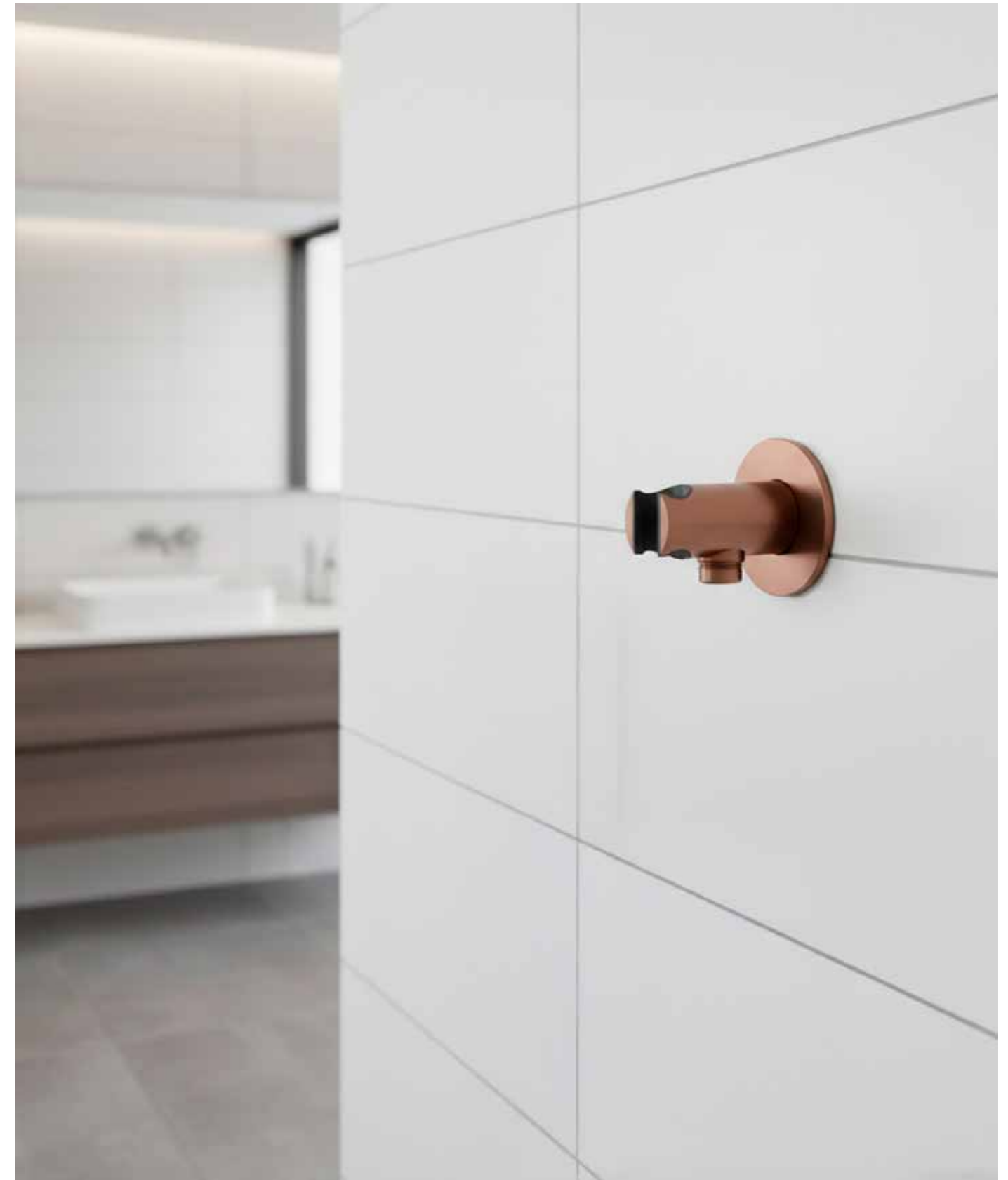
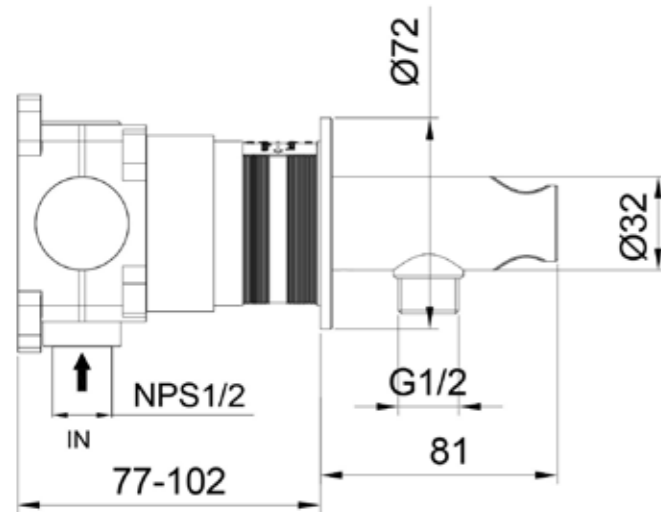

BOCCHETTA-PARETE-LEVANTE

STOCK



 **INOX** 8025431155848

PVD  **ORO-ROSA** 8025431156081

PVD  **CANNA-FUCILE** 8025431158702

PVD  **NERO** 8025431158719 *

PVD  **ORO** 8025431158726 *

*DISPONIBILE SOLO SU ORDINAZIONE

*AVAILABLE ONLY UPON REQUEST

CARATTERISTICHE

- **MATERIALE ACCIAIO INOX 316L / 316L STAINLESS STEEL**
- **BOCCHETTA LAVABO A PARETE DA INCASSO**
WALL-MOUNTED BUILT-IN BASIN SPOUT
- **INSTALLAZIONE A INCASSO CON BOX NASCOSTO**
CONCEALED INSTALLATION WITH HIDDEN BOX
- **CORPO INCASSO INCLUSO**
WALL RECESSED BODY INCLUDED
- **COMPLETAMENTE PRIVO DI PIOMBO**
COMPLETELY LEAD-FREE
- **PARTICOLARMENTE ADATTO PER AMBIENTI AD ALTO UTILIZZO O IN PROSSIMITÀ DEL MARE**
PARTICULARLY SUITABLE FOR HIGH-USE ENVIRONMENTS AND COASTAL AREAS
- **IDEALE PER STRUTTURE COME HOTEL, PISCINE PUBBLICHE, PALESTRE, AEROPORTI O BAGNI DI LOCALI CHE RICEVONO UN GRANDE FLUSSO DI UTENTI OGNI GIORNO**
IDEAL FOR FACILITIES SUCH AS HOTELS, PUBLIC POOLS, GYMS, AIRPORTS, AND HIGH-TRAFFIC RESTROOMS EXPERIENCE CONSTANT DAILY USE

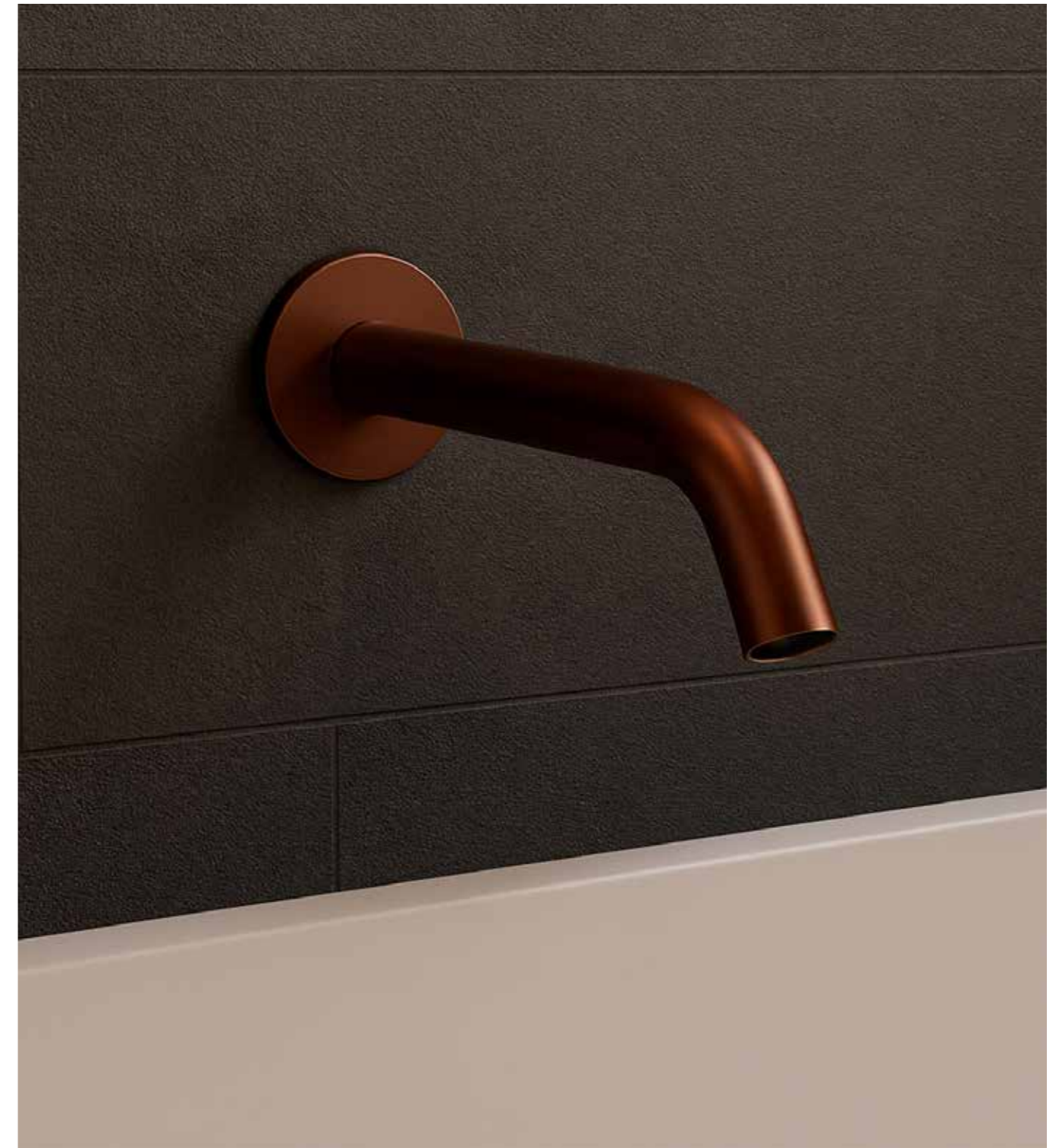
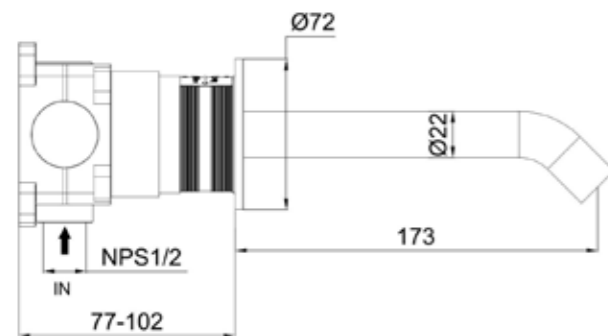

DOCCETTE E DOCCINI INOX 316L

316L STAINLESS STEEL HAND SHOWERS

Precisione, igiene e design essenziale

La collezione di doccette e shattaf SINED nasce per offrire soluzioni eleganti e funzionali ai gesti quotidiani del benessere personale.

Pensati per l'installazione a parete o integrati a sistemi bagno esistenti, questi accessori combinano estetica minimale con massima praticità.

Realizzati in acciaio inox AISI 316L, garantiscono igiene, resistenza e durata nel tempo, anche in ambienti umidi o ad uso intensivo.

L'impugnatura ergonomica e la qualità dei materiali assicurano un controllo preciso del getto, per un'esperienza d'uso confortevole e sicura.

Perfetti per contesti residenziali o professionali, rappresentano una scelta raffinata per bagni moderni attenti al dettaglio e alla funzionalità.

Steel that flows with style

The SINED collection of hand showers and shattafs was created to offer elegant and functional solutions for everyday personal wellness.

Designed for wall installation or integration into existing bathroom systems, these accessories combine minimalist aesthetics with maximum practicality.

Made of AISI 316L stainless steel, they guarantee hygiene, resistance and durability, even in humid environments or with intensive use.

The ergonomic handle and high-quality materials ensure precise control of the water flow, for a comfortable and safe user experience.

Perfect for residential or professional settings, they are a refined choice for modern bathrooms with an eye for detail and functionality.



DOCCINO-LEVANTE





STOCK

 **INOX** 8025431155718

PVD  **CANNA-FUCILE** 8025431158030

PVD  **ORO-ROSA** 8025431156869

PVD  **NERO** 8025431158047 *

PVD  **ORO** 8025431158054 *

 **BIANCO** 8025431158023 *

*DISPONIBILE SOLO SU ORDINAZIONE
*AVAILABLE ONLY UPON REQUEST

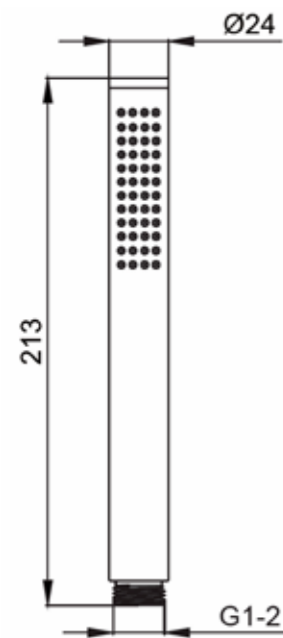

CARATTERISTICHE

- **MATERIALE ACCIAIO INOX 316L / 316L STAINLESS STEEL**
- **DOCCETTA**
HAND-HELD SHOWER
- **CONNESSIONE UNIVERSALE 1/2"**
UNIVERSAL CONNECTION 1/2"
- **COMPLETAMENTE PRIVO DI PIOMBO**
COMPLETELY LEAD-FREE
- **UGELLI IN SILICONE ANTICALCARE**
ANTI-LIMESCALE SILICONE NOZZLES

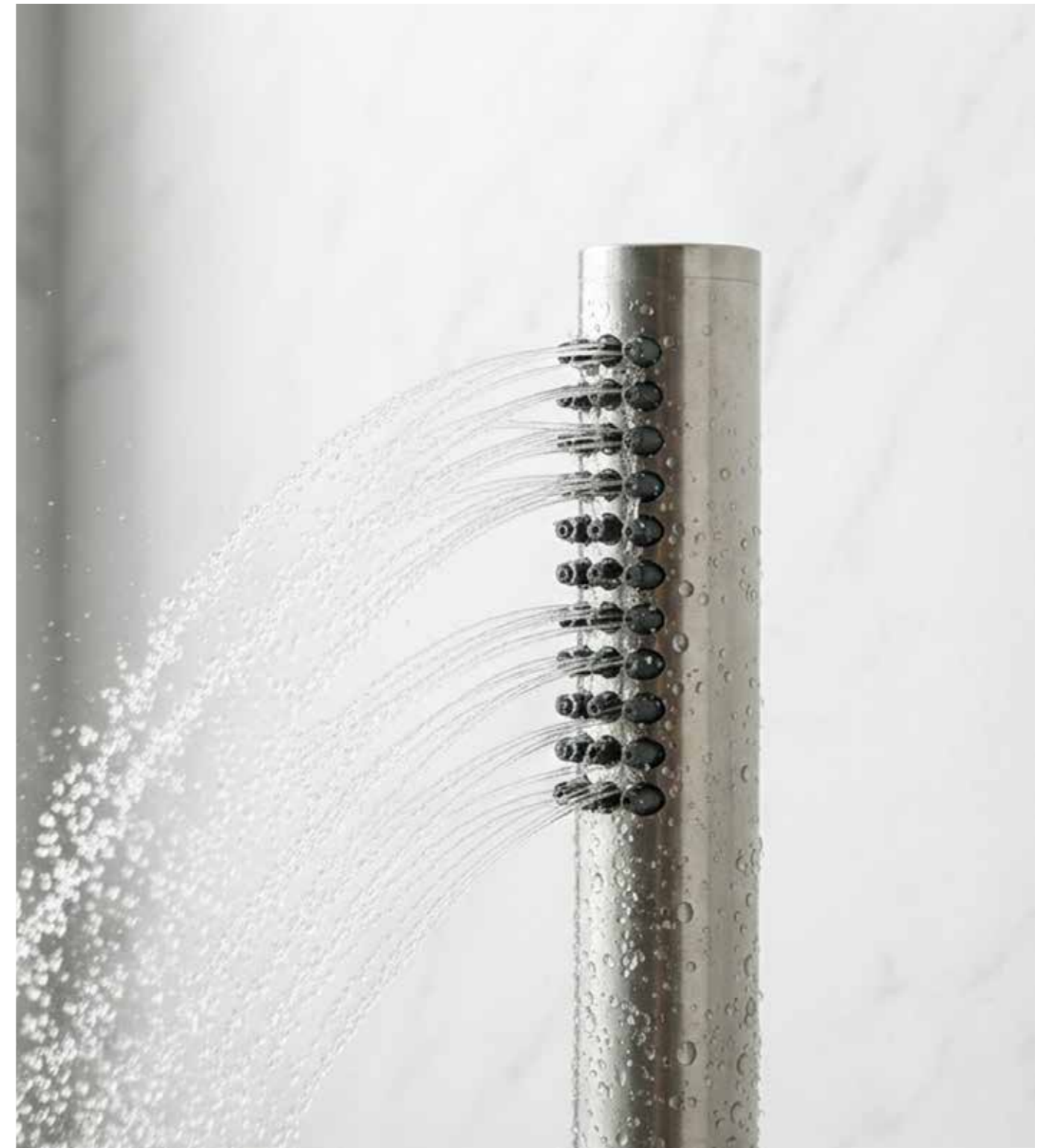

DOCGETTA-WATER-LEVANTE



STOCK

 **INOX** 8025431156821

PVD  **ORO-ROSA** 8025431156838

PVD  **CANNA-FUCILE** 8025431159341

CARATTERISTICHE

- **MATERIALE ACCIAIO INOX 316L / 316L STAINLESS STEEL**
- **DOCGETTA BIDET TIPO SHATTAF**
SHATTAFF BIDET HAND SHOWER
- **GETTO CON PULSANTE**
PUSH-BUTTON WATER JET
- **CONNESSIONE UNIVERSALE 1/2"**
UNIVERSAL CONNECTION 1/2"
- **COMPLETAMENTE PRIVO DI PIOMBO**
COMPLETELY LEAD-FREE

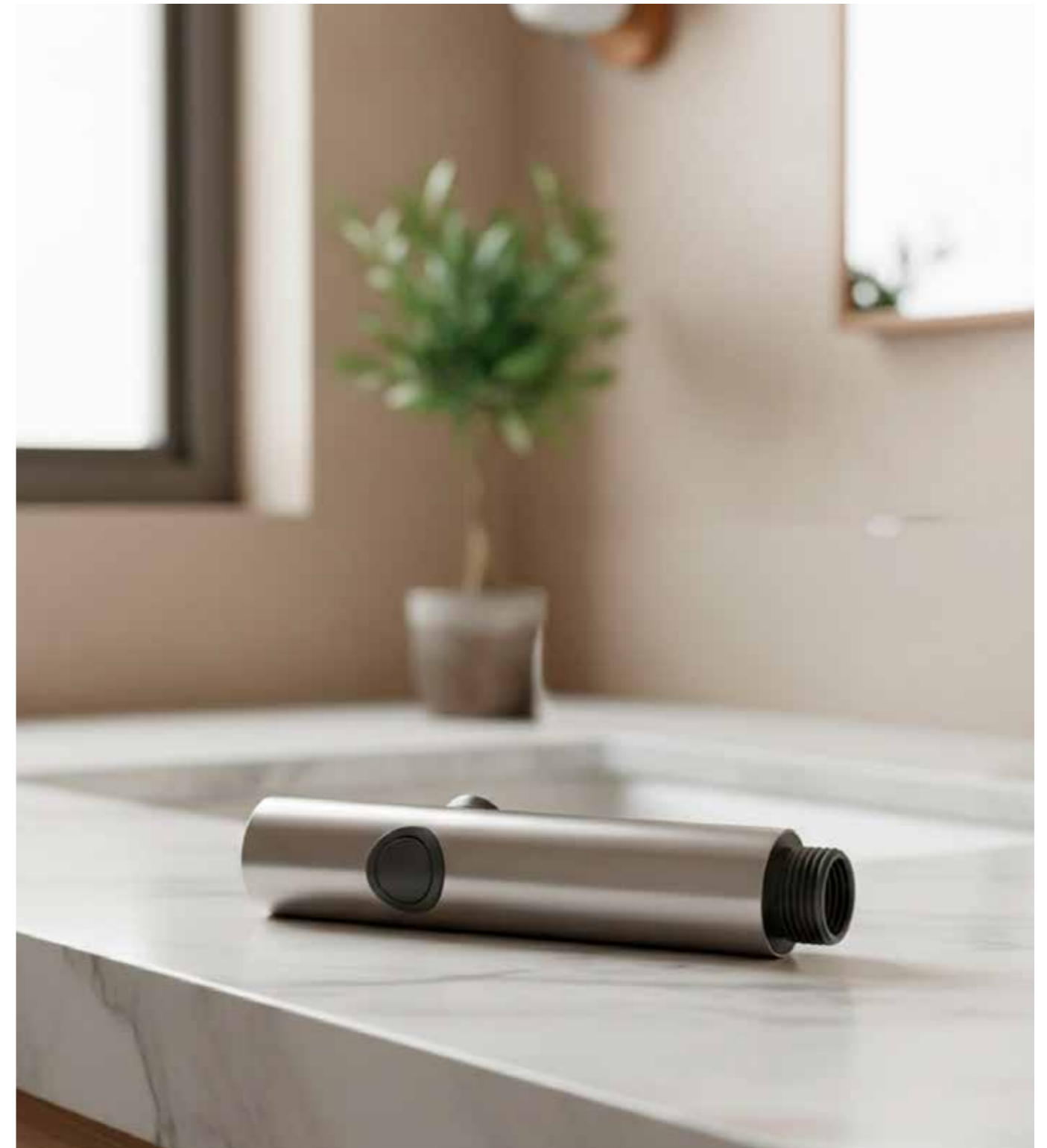
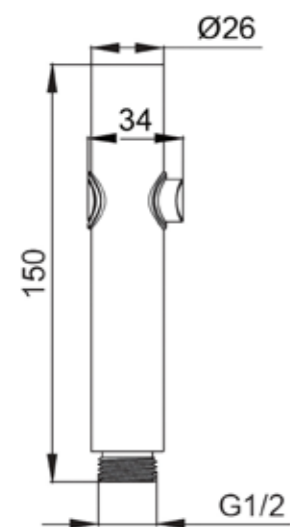

SHATTAF-BIDET-LEVANTE



STOCK

 INOX 8025431159617

PVD  ORO-ROSA 8025431159631

PVD  CANNA-FUCILE 8025431159624

CARATTERISTICHE

- **MATERIALE ACCIAIO INOX 316L / 316L STAINLESS STEEL**
- **DOCGETTA BIDET TIPO SHATTAF**
SHATTAFF BIDET HAND SHOWER
- **CONNESSIONE UNIVERSALE 1/2"**
UNIVERSAL CONNECTION 1/2"
- **COMPLETAMENTE PRIVO DI PIOMBO**
COMPLETELY LEAD-FREE



DOCCETTA-FLESSIBILE-MURO-LEVANTE

STOCK

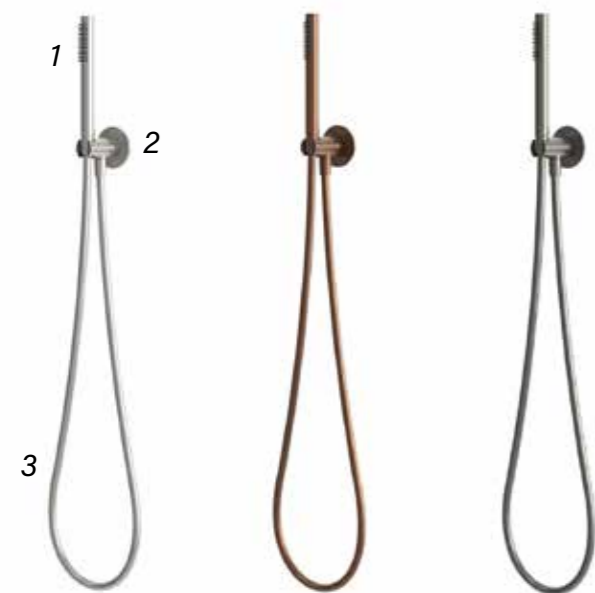

 INOX 8025431155923

PVD  ORO-ROSA 8025431156203

PVD  CANNA-FUCILE 8025431159334

CARATTERISTICHE

- **MATERIALE ACCIAIO INOX 316L / 316L STAINLESS STEEL**
- **DOCCETTA CON GETTO PIOGGIA**
HAND SHOWER WITH RAIN JET
- **COLLEGAMENTO A MURO**
WALL-MOUNTED CONNECTION
- **CORPO INCASSO INCLUSO**
WALL RECESSED BODY INCLUDED
- **COMPLETAMENTE PRIVO DI PIOMBO**
COMPLETELY LEAD-FREE
- **COMPONENTI KIT**
 1. DOCCINO-LEVANTE (PAG 196)
 2. SUPPORTO-MURO-DOCCINO-LEVANTE (PAG 190)
 3. TUBO-FLESSIBILE-LEVANTE-INOX
- **PARTICOLARMENTE ADATTO PER AMBIENTI AD ALTO UTILIZZO O IN PROSSIMITÀ DEL MARE**
PARTICULARLY SUITABLE FOR HIGH-USE ENVIRONMENTS AND COASTAL AREAS
- **IDEALE PER STRUTTURE COME HOTEL, PISCINE PUBBLICHE, PALESTRE, AEROPORTI O BAGNI DI LOCALI CHE RICEVONO UN GRANDE FLUSSO DI UTENTI OGNI GIORNO**
IDEAL FOR FACILITIES SUCH AS HOTELS, PUBLIC POOLS, GYMS, AIRPORTS, AND HIGH-TRAFFIC RESTROOMS EXPERIENCE CONSTANT DAILY USE

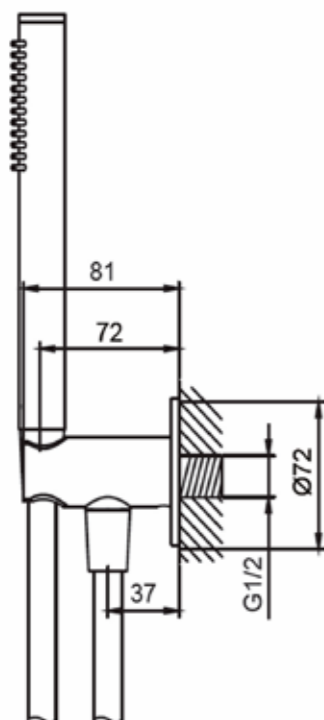

SOFFIONI INOX 316L E KIT

316L STAINLESS STEEL SHOWER HEADS AND KIT

Acciaio che scorre con stile

La collezione di soffioni e kit in acciaio inox AISI 316L eleva l'esperienza della doccia a un'espressione di design puro.

Ogni componente è studiato per offrire una sensazione avvolgente e naturale, con getti definiti e un'estetica senza tempo.

L'acciaio 316L garantisce massima resistenza alla corrosione, anche in ambienti umidi o outdoor.

Forme essenziali, finiture spazzolate e precisione tecnica si fondono in soluzioni complete e armoniose.

Kit progettati per integrarsi perfettamente in qualsiasi progetto contemporaneo, dove il benessere incontra l'architettura.

Una proposta che trasforma l'acqua in un'esperienza sensoriale di alto design.

Steel that flows with style

The collection of shower heads and kits in AISI 316L stainless steel elevates the shower experience into a pure design expression.

Each component is crafted to deliver a natural, immersive sensation, with defined jets and timeless aesthetics.

316L stainless steel ensures maximum corrosion resistance, even in humid or outdoor environments.

Essential shapes, brushed finishes, and technical precision come together in complete, harmonious solutions.

Kits designed to seamlessly integrate into any contemporary project, where wellness meets architecture.

A proposal that transforms water into a high-design sensory experience.



SOFFIONE-LEVANTE-25

STOCK

 **INOX** 8025431155725

 **CANNA-FUCILE** 8025431158085

 **ORO-ROSA** 8025431156166

 **NERO** 8025431158092 *

 **ORO** 8025431158108 *

 **BIANCO** 8025431158078 *

*DISPONIBILE SOLO SU ORDINAZIONE
*AVAILABLE ONLY UPON REQUEST

CARATTERISTICHE

- **MATERIALE ACCIAIO INOX 316L / 316L STAINLESS STEEL**
- **SOFFIONE DOCCIA Ø25 CM**
Ø25 CM SHOWER HEAD
- **ADATTO AD AMBIENTI AD ALTA ESPOSIZIONE**
SUITABLE FOR HIGH-EXPOSURE AREAS
- **BORDO RINFORZATO SPESSORE 6 MM**
REINFORCED EDGE, 6 MM THICKNESS
- **UGELLI IN SILICONE ANTICALCARE**
ANTI-LIME SILICONE NOZZLES
- **COMPLETAMENTE PRIVO DI PIOMBO**
COMPLETELY LEAD-FREE

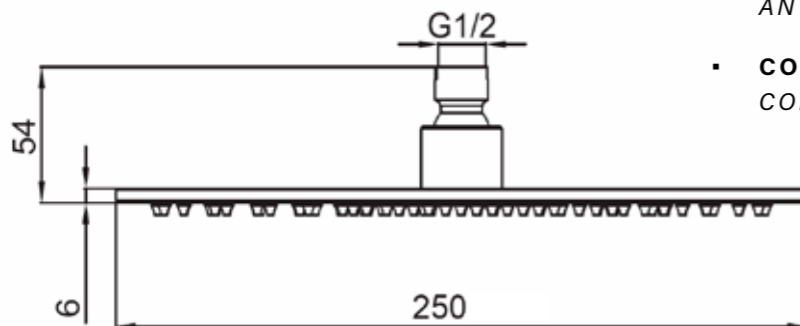

SOFFIONE-LEVANTE-30

STOCK

 **INOX** 8025431155732

 **CANNA-FUCILE** 8025431158122

 **ORO-ROSA** 8025431156173

 **NERO** 8025431158139 *

 **ORO** 8025431158146 *

 **BIANCO** 8025431158115 *

*DISPONIBILE SOLO SU ORDINAZIONE
*AVAILABLE ONLY UPON REQUEST

CARATTERISTICHE

- **MATERIALE ACCIAIO INOX 316L / 316L STAINLESS STEEL**
- **SOFFIONE DOCCIA Ø30 CM**
Ø30 CM SHOWER HEAD
- **ADATTO AD AMBIENTI AD ALTA ESPOSIZIONE**
SUITABLE FOR HIGH-EXPOSURE AREAS
- **BORDO RINFORZATO SPESSORE 6 MM**
REINFORCED EDGE, 6 MM THICKNESS
- **UGELLI IN SILICONE ANTICALCARE**
ANTI-LIME SILICONE NOZZLES
- **COMPLETAMENTE PRIVO DI PIOMBO**
COMPLETELY LEAD-FREE

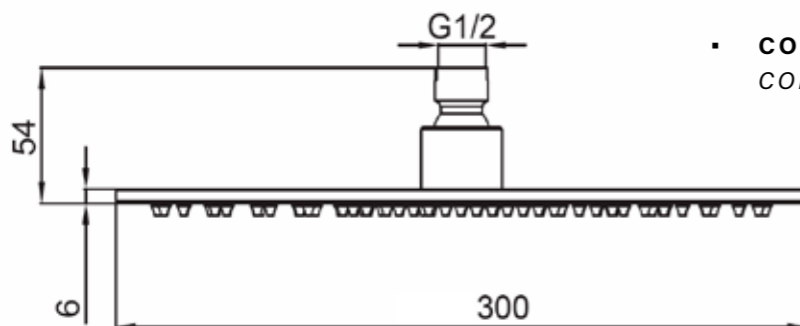

BRACCIO-DOCCIA-PARETE-LEVANTE

STOCK



 **INOX** 8025431155770

PVD  **CANNA-FUCILE** 8025431158733

PVD  **ORO-ROSA** 8025431156173

PVD  **NERO** 8025431158740 *

PVD  **ORO** 8025431158757 *

*DISPONIBILE SOLO SU ORDINAZIONE
*AVAILABLE ONLY UPON REQUEST

CARATTERISTICHE

- **MATERIALE ACCIAIO INOX 316L / 316L STAINLESS STEEL**
- **BRACCIO DOCCIA A PARETE**
WALL-MOUNTED SHOWER ARM
- **ATTACCO STANDARD PER SOFFIONE**
STANDARD SHOWER HEAD CONNECTION
- **INSTALLAZIONE A PARETE**
WALL INSTALLATION
- **COMPLETAMENTE PRIVO DI PIOMBO**
COMPLETELY LEAD-FREE

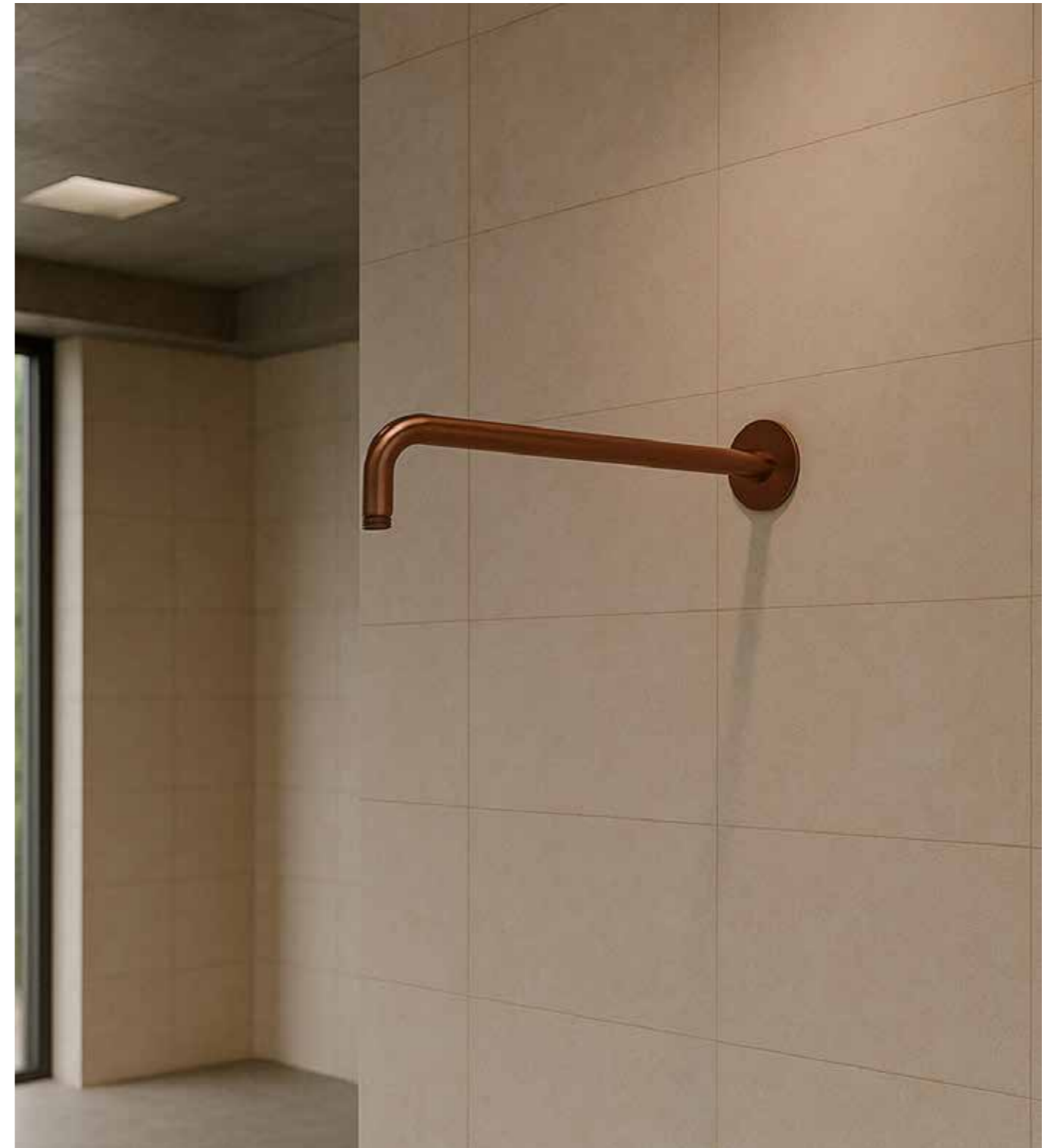
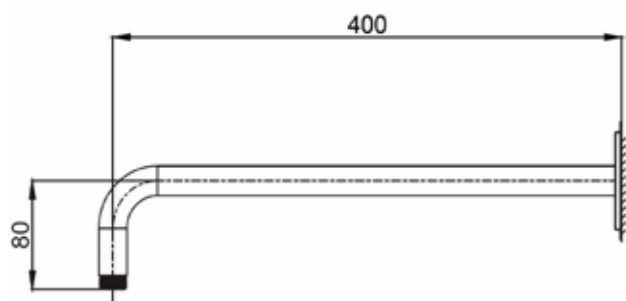

BRACCIO-DOCCIA-SOFFITTO-LEVANTE-CORTO

STOCK



 **INOX** 8025431155817

PVD  **CANNA-FUCILE** 8025431158764

PVD  **ORO-ROSA** 8025431156104

PVD  **NERO** 8025431158771 *

PVD  **ORO** 8025431158788 *

*DISPONIBILE SOLO SU ORDINAZIONE
*AVAILABLE ONLY UPON REQUEST

CARATTERISTICHE

- **MATERIALE ACCIAIO INOX 316L / 316L STAINLESS STEEL**
- **BRACCIO DOCCIA A SOFFITTO 120 CM**
120 CM CEILING SHOWER ARM
- **ATTACCO STANDARD PER SOFFIONE**
STANDARD SHOWER HEAD CONNECTION
- **INSTALLAZIONE A SOFFITTO**
CEILING INSTALLATION
- **COMPLETAMENTE PRIVO DI PIOMBO**
COMPLETELY LEAD-FREE

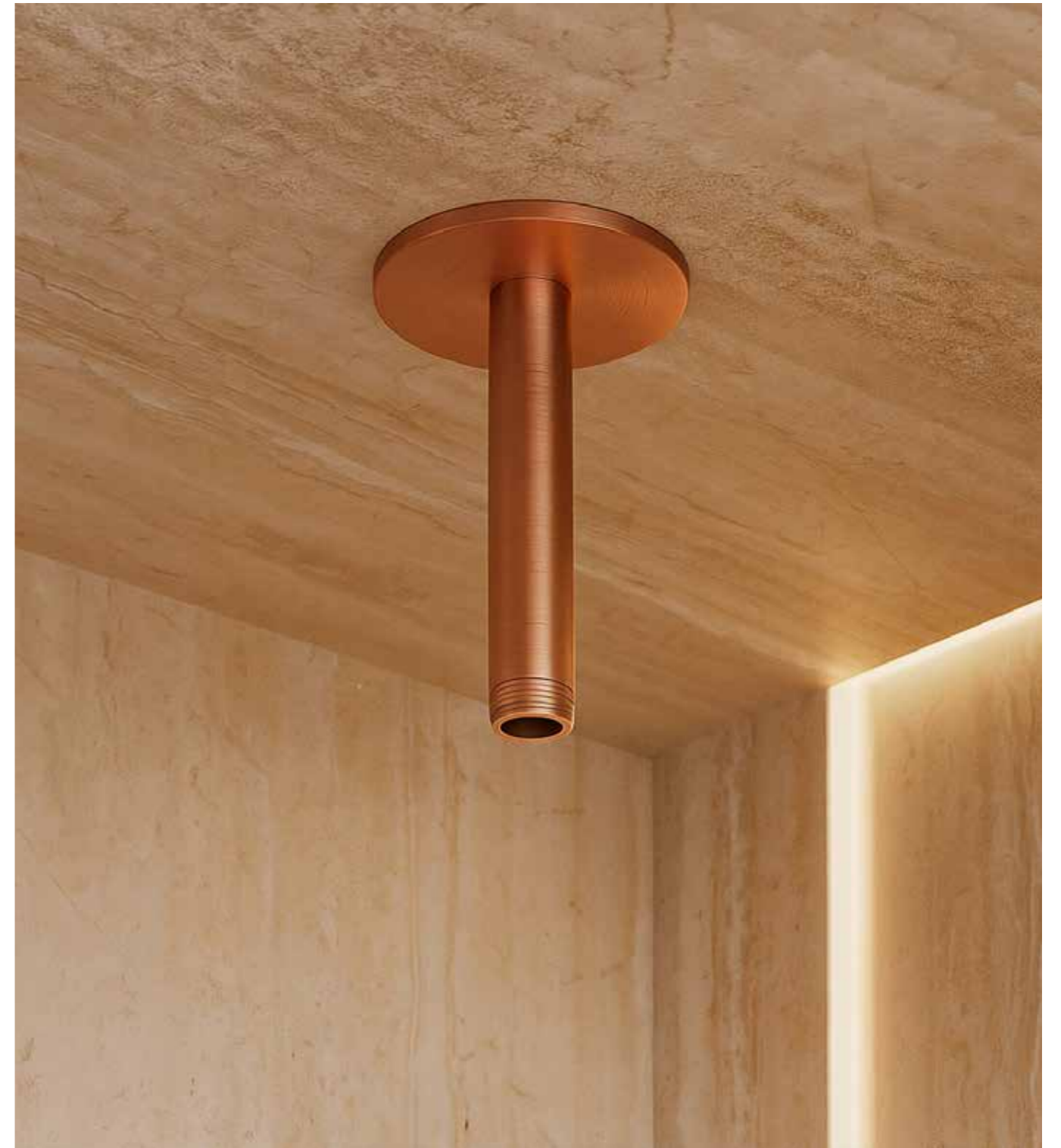
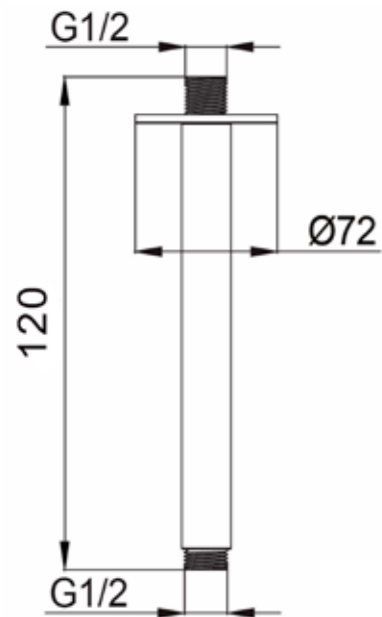

BRACCIO-DOCCIA-SOFFITTO-LEVANTE-LUNGO

STOCK



 INOX 8025431155787

PVD  CANNA-FUCILE 8025431158795

PVD  ORO-ROSA 8025431156111

PVD  NERO 8025431158801 *

PVD  ORO 8025431158818 *

*DISPONIBILE SOLO SU ORDINAZIONE

*AVAILABLE ONLY UPON REQUEST

CARATTERISTICHE

- **MATERIALE ACCIAIO INOX 316L / 316L STAINLESS STEEL**
- **BRACCIO DOCCIA A SOFFITTO 240 CM**
240 CM CEILING SHOWER ARM
- **ATTACCO STANDARD PER SOFFIONE**
STANDARD SHOWER HEAD CONNECTION
- **INSTALLAZIONE A SOFFITTO**
CEILING INSTALLATION
- **COMPLETAMENTE PRIVO DI PIOMBO**
COMPLETELY LEAD-FREE

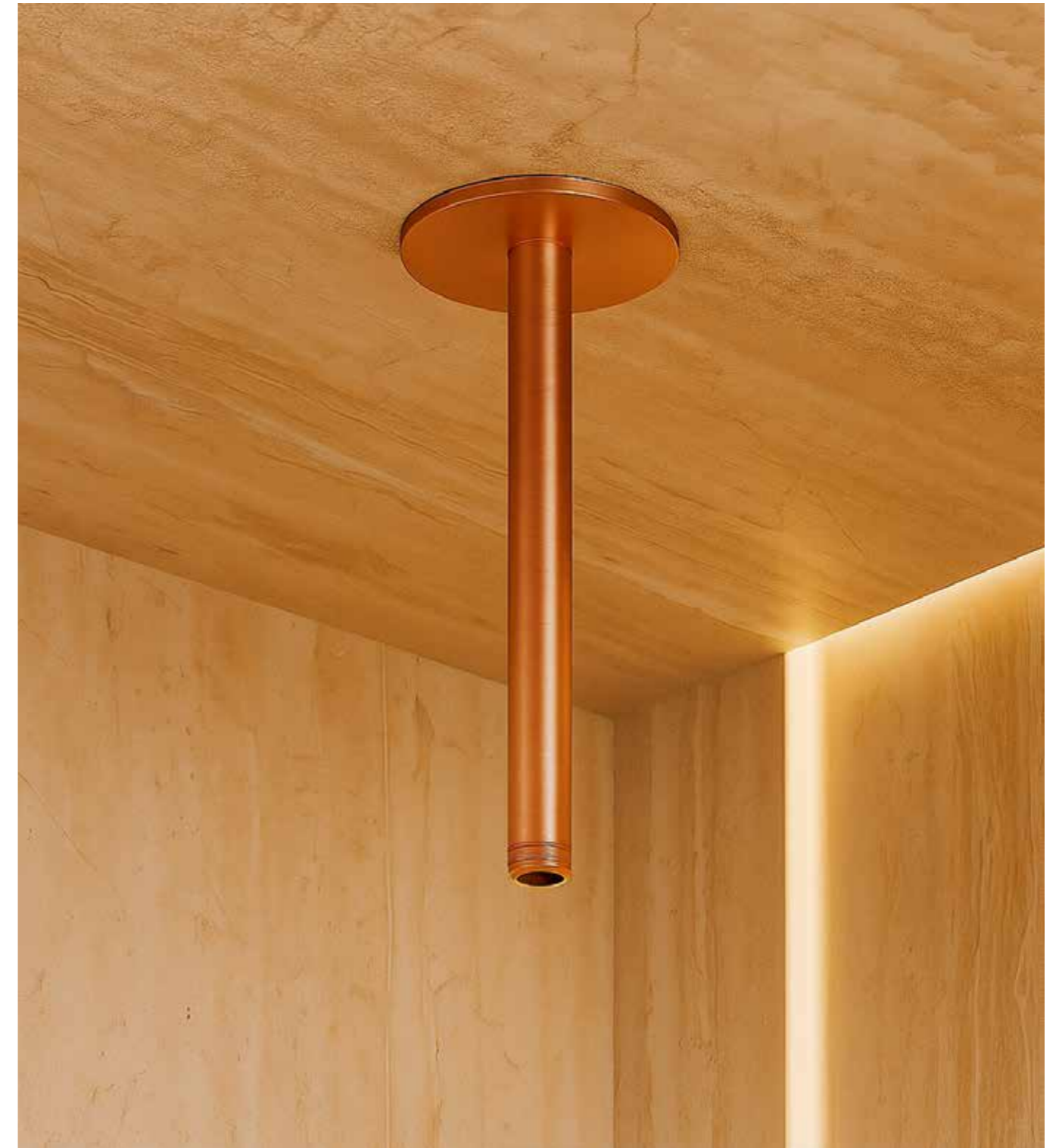
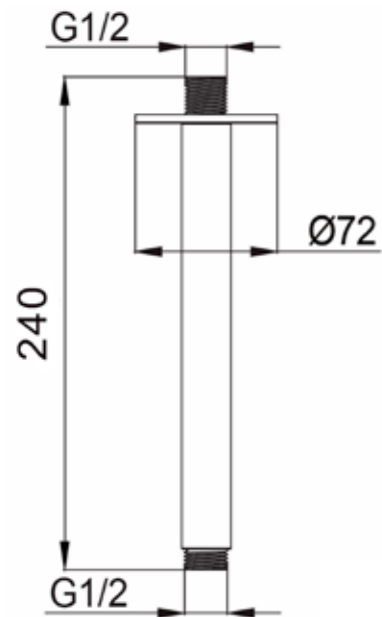

KIT-PARETE-SOFFIONE-LEVANTE-25

STOCK



 **INOX** 8025431155756

PVD  **ORO-ROSA** 8025431156142

PVD  **CANNA-FUCILE** 8025431159402

CARATTERISTICHE

- **MATERIALE ACCIAIO INOX 316L / 316L STAINLESS STEEL**
- **KIT DOCCIA A PARETE CON SOFFIONE Ø25CM**
WALL-MOUNTED SHOWER SET WITH Ø25 CM SHOWER HEAD
- **ADATTO AD AMBIENTI AD ALTA ESPOSIZIONE**
SUITABLE FOR HIGH-EXPOSURE AREAS
- **BORDO RINFORZATO SPESSORE 6 MM**
REINFORCED EDGE, 6 MM THICKNESS
- **UGELLI IN SILICONE ANTICALCARE**
ANTI-LIME SILICONE NOZZLES
- **COMPLETAMENTE PRIVO DI PIOMBO**
COMPLETELY LEAD-FREE
- **COMPONENTI SET**
 1. BRACCIO-DOCCIA-PARETE-LEVANTE (PAG 210)
 2. SOFFIONE-LEVANTE-25 (PAG 206)
- **PARTICOLARMENTE ADATTO PER AMBIENTI AD ALTO UTILIZZO O IN PROSSIMITÀ DEL MARE**
PARTICULARLY SUITABLE FOR HIGH-USE ENVIRONMENTS AND COASTAL AREAS
- **IDEALE PER STRUTTURE COME HOTEL, PISCINE PUBBLICHE, PALESTRE, AEROPORTI O BAGNI DI LOCALI CHE RICEVONO UN GRANDE FLUSSO DI UTENTI OGNI GIORNO**
IDEAL FOR FACILITIES SUCH AS HOTELS, PUBLIC POOLS, GYMS, AIRPORTS, AND HIGH-TRAFFIC RESTROOMS EXPERIENCE CONSTANT DAILY USE

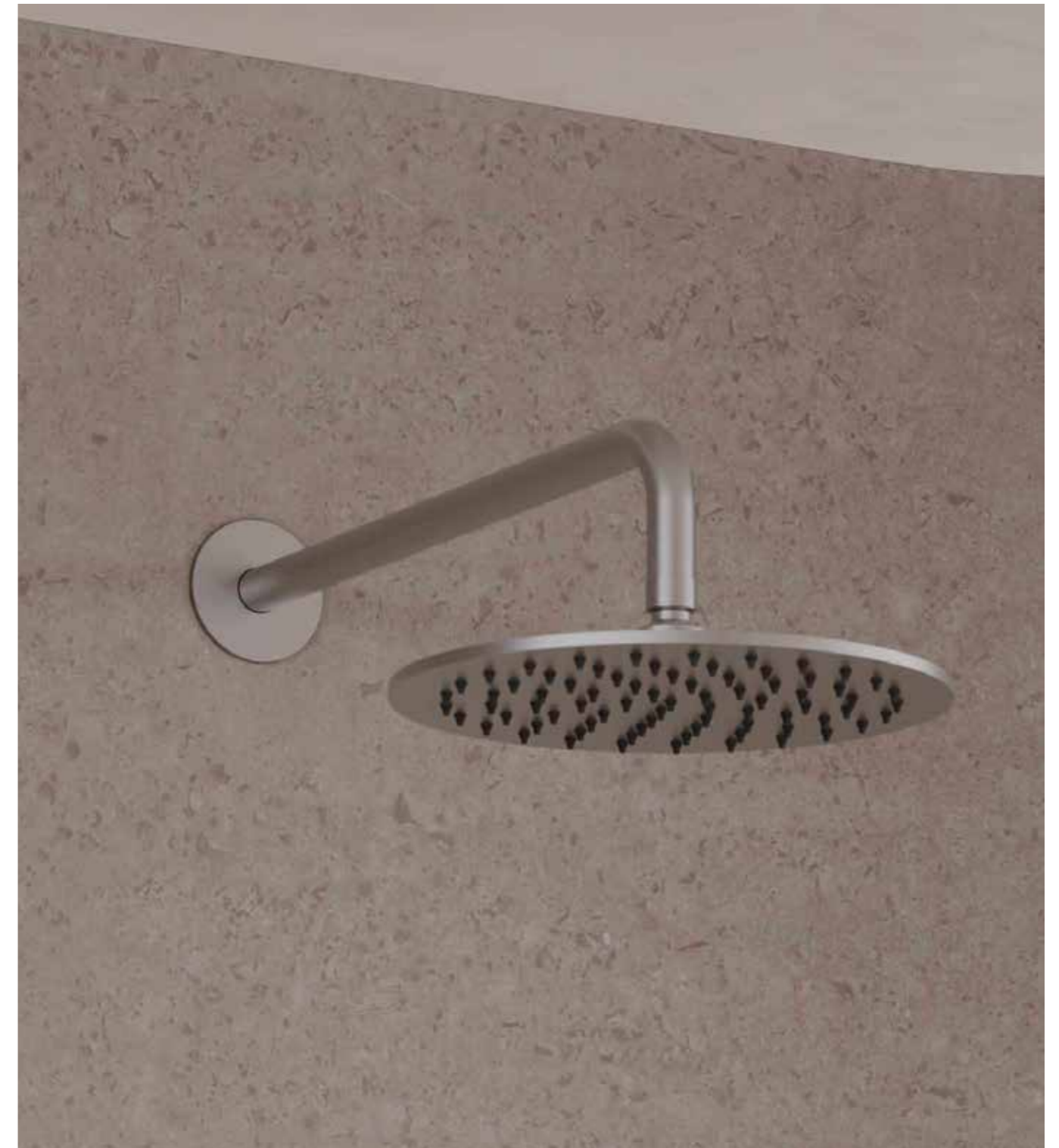
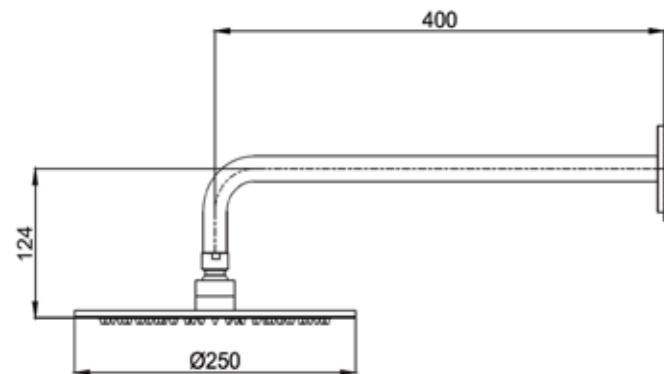

KIT-PARETE-SOFFIONE-LEVANTE-30

STOCK



 **INOX** 8025431155763

PVD  **ORO-ROSA** 8025431156159

PVD  **CANNA-FUCILE** 8025431159419



CARATTERISTICHE

- **MATERIALE ACCIAIO INOX 316L / 316L STAINLESS STEEL**
- **KIT DOCCIA A PARETE CON SOFFIONE Ø30CM**
WALL-MOUNTED SHOWER SET WITH Ø30 CM SHOWER HEAD
- **ADATTO AD AMBIENTI AD ALTA ESPOSIZIONE**
SUITABLE FOR HIGH-EXPOSURE AREAS
- **BORDO RINFORZATO SPESSORE 6 MM**
REINFORCED EDGE, 6 MM THICKNESS
- **UGELLI IN SILICONE ANTICALCARE**
ANTI-LIME SILICONE NOZZLES
- **COMPLETAMENTE PRIVO DI PIOMBO**
COMPLETELY LEAD-FREE
- **COMPONENTI SET**
 1. BRACCIO-DOCCIA-PARETE-LEVANTE (PAG 210)
 2. SOFFIONE-LEVANTE-30 (PAG 208)
- **PARTICOLARMENTE ADATTO PER AMBIENTI AD ALTO UTILIZZO O IN PROSSIMITÀ DEL MARE**
PARTICULARLY SUITABLE FOR HIGH-USE ENVIRONMENTS AND COASTAL AERAS
- **IDEALE PER STRUTTURE COME HOTEL, PISCINE PUBBLICHE, PALESTRE, AEROPORTI O BAGNI DI LOCALI CHE RICEVONO UN GRANDE FLUSSO DI UTENTI OGNI GIORNO**
IDEAL FOR FACILITIES SUCH AS HOTELS, PUBLIC POOLS, GYMS, AIRPORTS, AND HIGH-TRAFFIC RESTROOMS EXPERIENCE CONSTANT DAILY USE

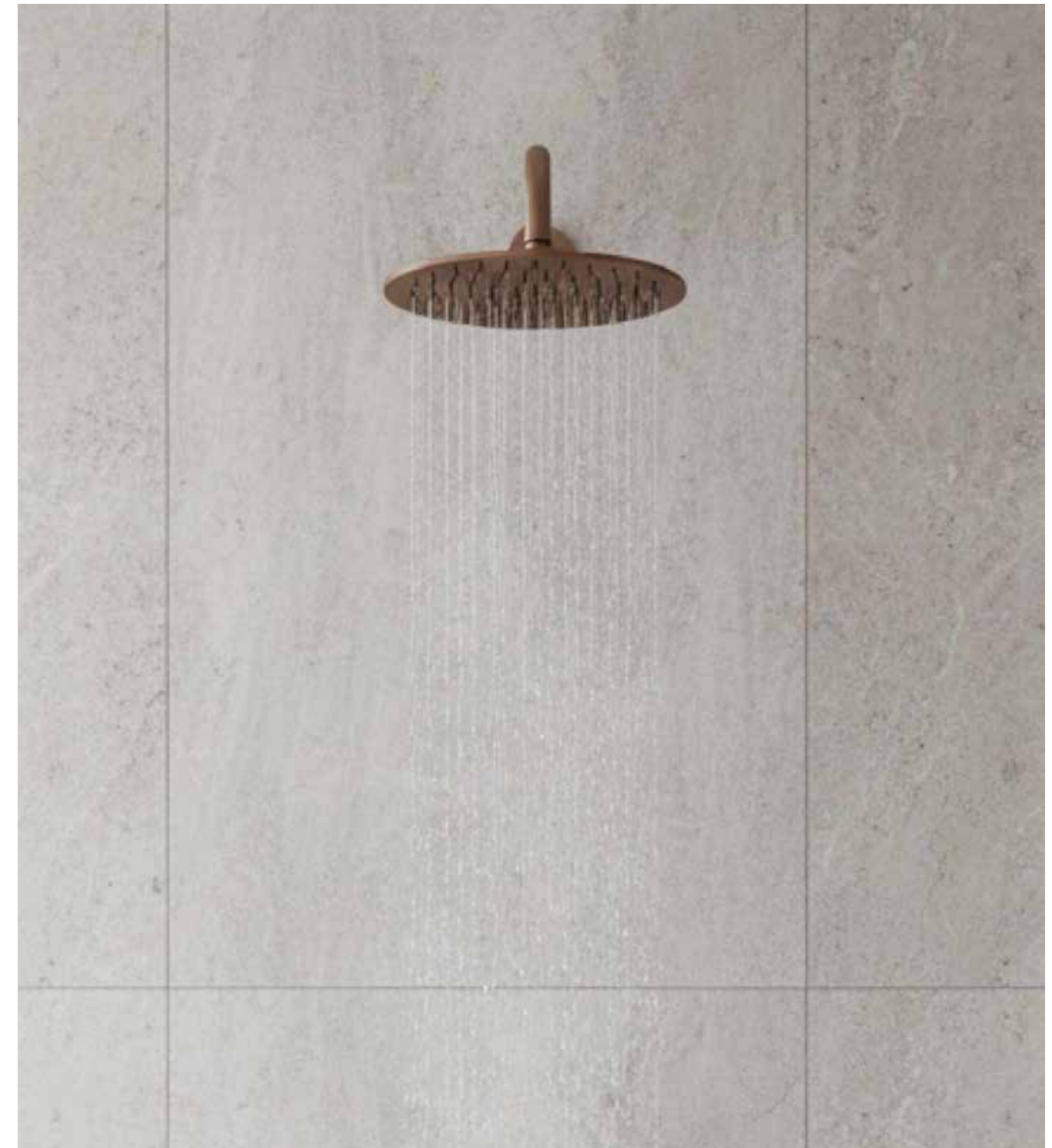
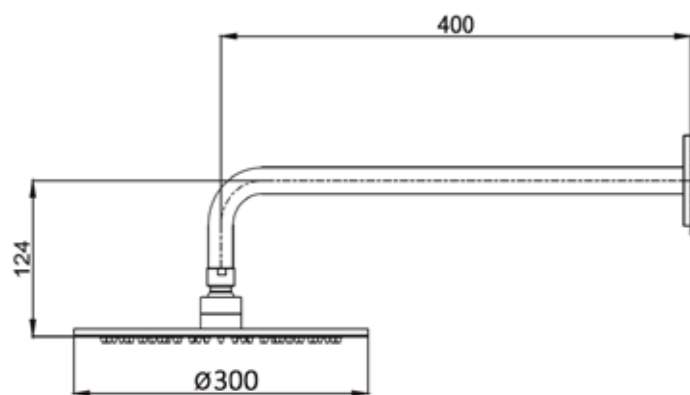

KIT-SOFFITTO-SOFFIONE-LEVANTE-CORTO

STOCK Ø25



INOX 8025431155824

PVD ORO-ROSA 8025431156876

PVD CANNA-FUCILE 8025431159433

STOCK Ø30



INOX 8025431155831

PVD ORO-ROSA 8025431156883

PVD CANNA-FUCILE 8025431159440

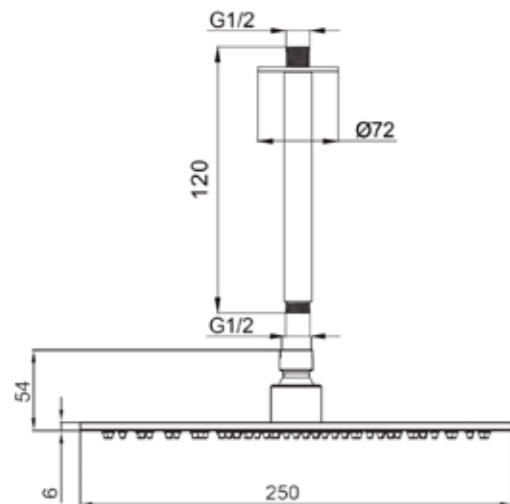

CARATTERISTICHE

- **MATERIALE ACCIAIO INOX 316L / 316L STAINLESS STEEL**
- **KIT DOCCIA A SOFFITTO CON SOFFIONE Ø25/30 CM**
CEILING SHOWER SET WITH Ø25/30 CM SHOWER HEAD
- **ADATTO AD AMBIENTI AD ALTA ESPOSIZIONE**
SUITABLE FOR HIGH-EXPOSURE AREAS
- **BORDO RINFORZATO SPESSORE 6 MM**
REINFORCED EDGE, 6 MM THICKNESS
- **UGELLI IN SILICONE ANTICALCARE**
ANTI-LIME SILICONE NOZZLES
- **COMPLETAMENTE PRIVO DI PIOMBO**
COMPLETELY LEAD-FREE
- **COMPONENTI KIT**
 1. BRACCIO-DOCCIA-SOFFITTO-LEVANTE-CORTO (PAG 212)
 2. SOFFIONE-LEVANTE-25 O SOFFIONE-LEVANTE-30 (PAG 206-208)
- **IDEALE PER STRUTTURE COME HOTEL, PISCINE PUBBLICHE, PALESTRE, AEROPORTI O BAGNI DI LOCALI CHE RICEVONO UN GRANDE FLUSSO DI UTENTI OGNI GIORNO**
IDEAL FOR FACILITIES SUCH AS HOTELS, PUBLIC POOLS, GYMS, AIRPORTS, AND HIGH-TRAFFIC RESTROOMS EXPERIENCE CONSTANT DAILY USE



KIT-SOFFITTO-SOFFIONE-LEVANTE-LUNGO

STOCK Ø25



 **INOX** 8025431155794

PVD  **ORO-ROSA** 8025431156890

PVD  **CANNA-FUCILE** 8025431159457

STOCK Ø30



 **INOX** 8025431155800

PVD  **ORO-ROSA** 8025431156906

PVD  **CANNA-FUCILE** 8025431159464

CARATTERISTICHE

- **MATERIALE ACCIAIO INOX 316L / 316L STAINLESS STEEL**
- **KIT DOCCIA A SOFFITTO CON SOFFIONE Ø25/30 CM**
CEILING SHOWER SET WITH Ø25/30 CM SHOWER HEAD
- **ADATTO AD AMBIENTI AD ALTA ESPOSIZIONE**
SUITABLE FOR HIGH-EXPOSURE AREAS
- **BORDO RINFORZATO SPESSORE 6 MM**
REINFORCED EDGE, 6 MM THICKNESS
- **UGELLI IN SILICONE ANTICALCARE**
ANTI-LIME SILICONE NOZZLES
- **COMPLETAMENTE PRIVO DI PIOMBO**
COMPLETELY LEAD-FREE
- **COMPONENTI KIT**
 1. **BRACCIO-DOCCIA-SOFFITTO-LEVANTE-LUNGO**
(PAG 214)
 2. **SOFFIONE-LEVANTE-25 O SOFFIONE-LEVANTE-30**
(PAG 206-208)
- **IDEALE PER STRUTTURE COME HOTEL, PISCINE PUBBLICHE, PALESTRE, AEROPORTI O BAGNI DI LOCALI CHE RICEVONO UN GRANDE FLUSSO DI UTENTI OGNI GIORNO**
IDEAL FOR FACILITIES SUCH AS HOTELS, PUBLIC POOLS, GYMS, AIRPORTS, AND HIGH-TRAFFIC RESTROOMS EXPERIENCE CONSTANT DAILY USE

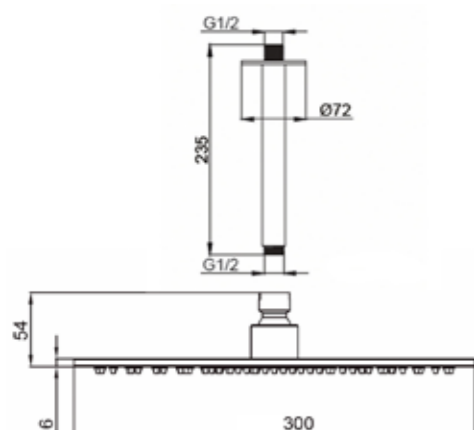
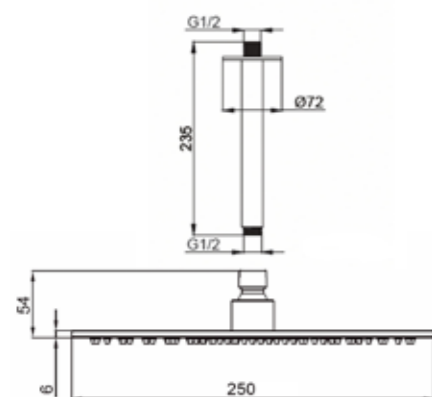

ACCESSORI PER IL BAGNO

BATHROOM ACCESSORIES

Dettagli funzionali, estetica coordinata

Gli accessori da bagno SINED completano lo spazio con coerenza e precisione progettuale. Porta rotoli, porta saponi, porta asciugamani e altri elementi da appoggio o a parete sono realizzati in acciaio inox AISI 316L, per garantire resistenza all'umidità, durata nel tempo e una manutenzione minima.

Ogni pezzo nasce per dialogare con le collezioni doccia e rubinetteria, mantenendo una continuità formale e materica che valorizza l'ambiente.

Linee pulite, finiture satinare e installazioni semplici trasformano gli oggetti quotidiani in componenti di arredo discreti ma essenziali.

La funzionalità incontra il design anche nei dettagli.

Functional details, coordinated aesthetics

SINED bathroom accessories complete the space with consistency and precision in design. Toilet roll holders, soap dishes, towel rails and other countertop or wall-mounted items are made of AISI 316L stainless steel to ensure resistance to humidity, durability and minimal maintenance.

Each piece is designed to complement the shower and tap collections, maintaining a continuity of form and material that enhances the environment.

Clean lines, satin finishes and simple installations transform everyday objects into discreet but essential pieces of furniture.

Functionality meets design even in the details.



PORTA-ROTOLO-LEVANTE

STOCK



 INOX 8025431155961

PVD  ORO-ROSA 8025431157132

PVD  CANNA-FUCILE 8025431159563



CARATTERISTICHE

- **MATERIALE ACCIAIO INOX 316L / 316L STAINLESS STEEL**
- **PORTA ROTOLO WC A PARETE**
WALL-MOUNTED TOILET ROLL HOLDER
- **INSTALLAZIONE A MURO**
WALL INSTALLATION
- **COMPLETAMENTE PRIVO DI PIOMBO**
COMPLETELY LEAD-FREE
- **PARTICOLARMENTE ADATTO PER AMBIENTI AD ALTO UTILIZZO O IN PROSSIMITÀ DEL MARE**
PARTICULARLY SUITABLE FOR HIGH-USE ENVIRONMENTS AND COASTAL AREAS
- **IDEALE PER STRUTTURE COME HOTEL, PISCINE PUBBLICHE, PALESTRE, AEROPORTI O BAGNI DI LOCALI CHE RICEVONO UN GRANDE FLUSSO DI UTENTI OGNI GIORNO**
IDEAL FOR FACILITIES SUCH AS HOTELS, PUBLIC POOLS, GYMS, AIRPORTS, AND HIGH-TRAFFIC RESTROOMS EXPERIENCE CONSTANT DAILY USE

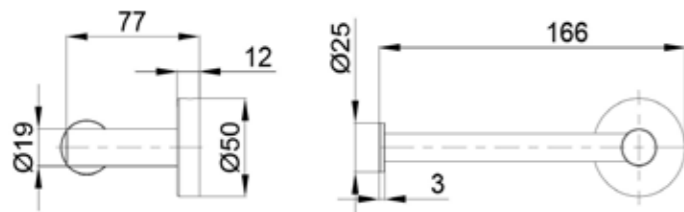

PORTA-ROTOLO-APPOGGIO-LEVANTE

STOCK



 INOX 8025431155954

PVD  ORO-ROSA 8025431157125

PVD  CANNA-FUCILE 8025431159556



CARATTERISTICHE

- **MATERIALE ACCIAIO INOX 316L / 316L STAINLESS STEEL**
- **PORTA ROTOLO DA APPOGGIO
FREE-STANDING TOILET ROLL HOLDER**
- **INSTALLAZIONE A MURO
WALL INSTALLATION**
- **COMPLETAMENTE PRIVO DI PIOMBO
COMPLETELY LEAD-FREE**
- **PARTICOLARMENTE ADATTO PER AMBIENTI AD ALTO UTILIZZO O IN PROSSIMITÀ DEL MARE
PARTICULARLY SUITABLE FOR HIGH-USE ENVIRONMENTS AND COASTAL AERAS**
- **IDEALE PER STRUTTURE COME HOTEL, PISCINE PUBBLICHE, PALESTRE, AEROPORTI O BAGNI DI LOCALI CHE RICEVONO UN GRANDE FLUSSO DI UTENTI OGNI GIORNO
IDEAL FOR FACILITIES SUCH AS HOTELS, PUBLIC POOLS, GYMS, AIRPORTS, AND HIGH-TRAFFIC RESTROOMS EXPERIENCE CONSTANT DAILY USE**

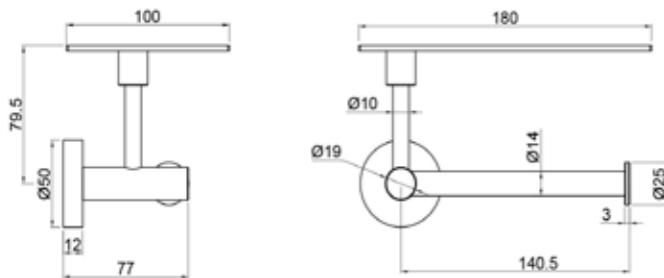

PORTA-BICCHIERE-LEVANTE-SINGOLO

STOCK



 **INOX** 8025431156012

PVD  **ORO-ROSA** 8025431157118

PVD  **CANNA-FUCILE** 8025431159549



CARATTERISTICHE

- **MATERIALE ACCIAIO INOX 316L / 316L STAINLESS STEEL**
- **PORTA BICCHIERE SINGOLO A PARETE**
WALL-MOUNTED SINGLE GLASS HOLDER
- **INSTALLAZIONE A MURO**
WALL INSTALLATION
- **COMPLETAMENTE PRIVO DI PIOMBO**
COMPLETELY LEAD-FREE
- **PARTICOLARMENTE ADATTO PER AMBIENTI AD ALTO UTILIZZO O IN PROSSIMITÀ DEL MARE**
PARTICULARLY SUITABLE FOR HIGH-USE ENVIRONMENTS AND COASTAL AREAS
- **IDEALE PER STRUTTURE COME HOTEL, PISCINE PUBBLICHE, PALESTRE, AEROPORTI O BAGNI DI LOCALI CHE RICEVONO UN GRANDE FLUSSO DI UTENTI OGNI GIORNO**
IDEAL FOR FACILITIES SUCH AS HOTELS, PUBLIC POOLS, GYMS, AIRPORTS, AND HIGH-TRAFFIC RESTROOMS EXPERIENCE CONSTANT DAILY USE

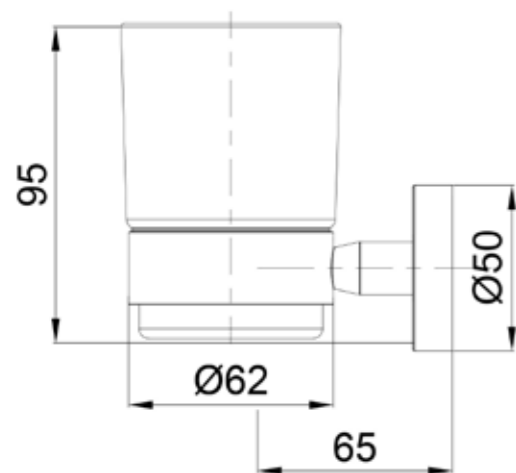

PORTA-BICCHIERE-LEVANTE-DOPPIO

STOCK



 INOX 8025431156005

PVD  ORO-ROSA 8025431157101

PVD  CANNA-FUCILE 8025431159532



CARATTERISTICHE

- **MATERIALE ACCIAIO INOX 316L / 316L STAINLESS STEEL**
- **PORTA BICCHIERE DOPPIO A PARETE**
WALL-MOUNTED DOUBLE GLASS HOLDER
- **INSTALLAZIONE A MURO**
WALL INSTALLATION
- **COMPLETAMENTE PRIVO DI PIOMBO**
COMPLETELY LEAD-FREE
- **PARTICOLARMENTE ADATTO PER AMBIENTI AD ALTO UTILIZZO O IN PROSSIMITÀ DEL MARE**
PARTICULARLY SUITABLE FOR HIGH-USE ENVIRONMENTS AND COASTAL AREAS
- **IDEALE PER STRUTTURE COME HOTEL, PISCINE PUBBLICHE, PALESTRE, AEROPORTI O BAGNI DI LOCALI CHE RICEVONO UN GRANDE FLUSSO DI UTENTI OGNI GIORNO**
IDEAL FOR FACILITIES SUCH AS HOTELS, PUBLIC POOLS, GYMS, AIRPORTS, AND HIGH-TRAFFIC RESTROOMS EXPERIENCE CONSTANT DAILY USE

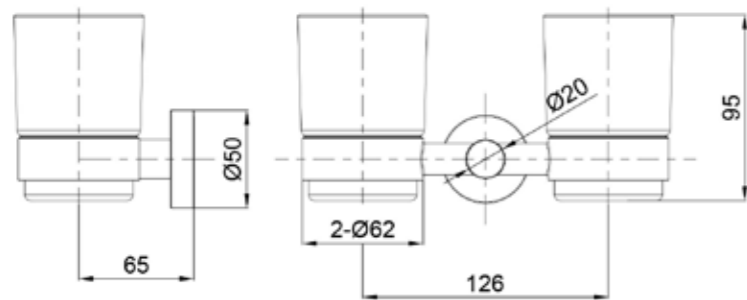

PORTA-SAPONE-LEVANTE

STOCK



 **INOX** 8025431155992

PVD  **ORO-ROSA** 8025431157149

PVD  **CANNA-FUCILE** 8025431159570



CARATTERISTICHE

- **MATERIALE ACCIAIO INOX 316L / 316L STAINLESS STEEL**
- **PORTA SAPONE A PARETE**
WALL-MOUNTED SOAP DISH
- **INSTALLAZIONE A MURO**
WALL INSTALLATION
- **COMPLETAMENTE PRIVO DI PIOMBO**
COMPLETELY LEAD-FREE
- **PARTICOLARMENTE ADATTO PER AMBIENTI AD ALTO UTILIZZO O IN PROSSIMITÀ DEL MARE**
PARTICULARLY SUITABLE FOR HIGH-USE ENVIRONMENTS AND COASTAL AREAS
- **IDEALE PER STRUTTURE COME HOTEL, PISCINE PUBBLICHE, PALESTRE, AEROPORTI O BAGNI DI LOCALI CHE RICEVONO UN GRANDE FLUSSO DI UTENTI OGNI GIORNO**
IDEAL FOR FACILITIES SUCH AS HOTELS, PUBLIC POOLS, GYMS, AIRPORTS, AND HIGH-TRAFFIC RESTROOMS EXPERIENCE CONSTANT DAILY USE

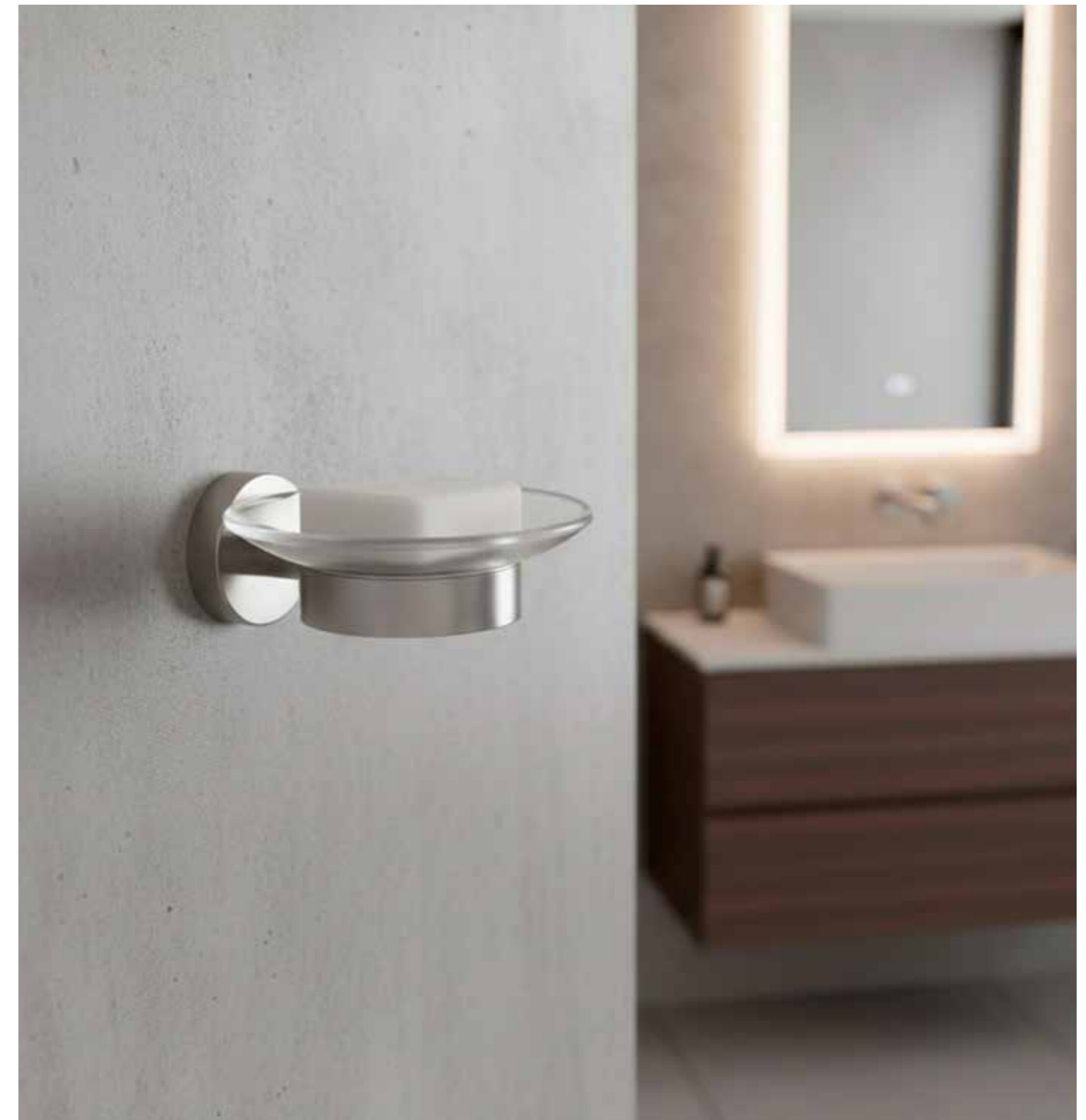
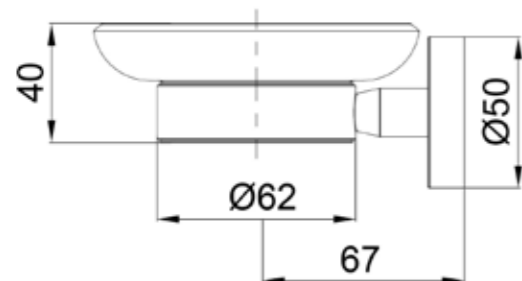

PORTA-SCOPINO-LEVANTE



STOCK

 **INOX** 8025431155978

PVD  **ORO-ROSA** 8025431157156

PVD  **CANNA-FUCILE** 8025431159587

CARATTERISTICHE

- **MATERIALE ACCIAIO INOX 316L / 316L STAINLESS STEEL**
- **PORTA SCOPINO WC A PARETE**
WALL-MOUNTED TOILET BRUSH HOLDER
- **INSTALLAZIONE A MURO**
WALL INSTALLATION
- **COMPLETAMENTE PRIVO DI PIOMBO**
COMPLETELY LEAD-FREE
- **PARTICOLARMENTE ADATTO PER AMBIENTI AD ALTO UTILIZZO O IN PROSSIMITÀ DEL MARE**
PARTICULARLY SUITABLE FOR HIGH-USE ENVIRONMENTS AND COASTAL AREAS
- **IDEALE PER STRUTTURE COME HOTEL, PISCINE PUBBLICHE, PALESTRE, AEROPORTI O BAGNI DI LOCALI CHE RICEVONO UN GRANDE FLUSSO DI UTENTI OGNI GIORNO**
IDEAL FOR FACILITIES SUCH AS HOTELS, PUBLIC POOLS, GYMS, AIRPORTS, AND HIGH-TRAFFIC RESTROOMS EXPERIENCE CONSTANT DAILY USE

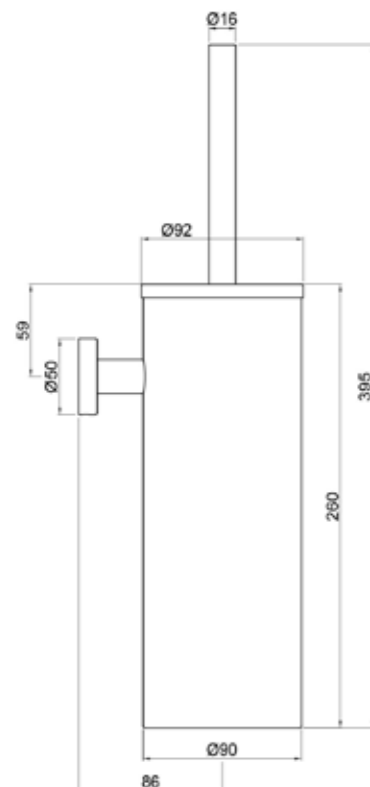

GANCIO-MURO-SINGOLO-LEVANTE

STOCK



 INOX 8025431159617

PVD  ORO-ROSA 8025431159600

PVD  CANNA-FUCILE 8025431159624

CARATTERISTICHE

- **MATERIALE ACCIAIO INOX 316L / 316L STAINLESS STEEL**
- **PORTA ASCIUGAMANI A PARETE**
WALL-MOUNTED TOWEL RAIL
- **INSTALLAZIONE A MURO**
WALL INSTALLATION
- **COMPLETAMENTE PRIVO DI PIOMBO**
COMPLETELY LEAD-FREE
- **PARTICOLARMENTE ADATTO PER AMBIENTI AD ALTO UTILIZZO O IN PROSSIMITÀ DEL MARE**
PARTICULARLY SUITABLE FOR HIGH-USE ENVIRONMENTS AND COASTAL AREAS
- **IDEALE PER STRUTTURE COME HOTEL, PISCINE PUBBLICHE, PALESTRE, AEROPORTI O BAGNI DI LOCALI CHE RICEVONO UN GRANDE FLUSSO DI UTENTI OGNI GIORNO**
IDEAL FOR FACILITIES SUCH AS HOTELS, PUBLIC POOLS, GYMS, AIRPORTS, AND HIGH-TRAFFIC RESTROOMS EXPERIENCE CONSTANT DAILY USE

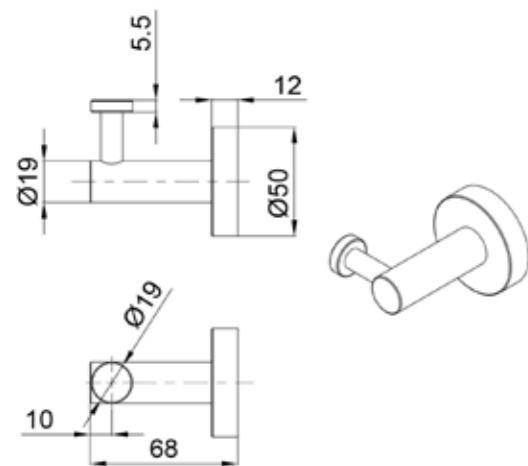

GANCIO-MURO-DOPPIO-LEVANTE

STOCK



 INOX 8025431155985

PVD  ORO-ROSA 8025431157095

PVD  CANNA-FUCILE 8025431159396

CARATTERISTICHE

- **MATERIALE ACCIAIO INOX 316L / 316L STAINLESS STEEL**
- **PORTA ASCIUGAMANI A PARETE**
WALL-MOUNTED TOWEL RAIL
- **INSTALLAZIONE A MURO**
WALL INSTALLATION
- **COMPLETAMENTE PRIVO DI PIOMBO**
COMPLETELY LEAD-FREE
- **PARTICOLARMENTE ADATTO PER AMBIENTI AD ALTO UTILIZZO O IN PROSSIMITÀ DEL MARE**
PARTICULARLY SUITABLE FOR HIGH-USE ENVIRONMENTS AND COASTAL AREAS
- **IDEALE PER STRUTTURE COME HOTEL, PISCINE PUBBLICHE, PALESTRE, AEROPORTI O BAGNI DI LOCALI CHE RICEVONO UN GRANDE FLUSSO DI UTENTI OGNI GIORNO**
IDEAL FOR FACILITIES SUCH AS HOTELS, PUBLIC POOLS, GYMS, AIRPORTS, AND HIGH-TRAFFIC RESTROOMS EXPERIENCE CONSTANT DAILY USE

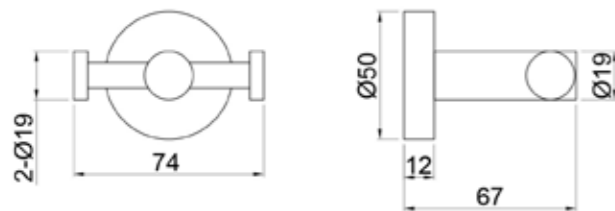

PILETTA-SCARICO-LEVANTE

STOCK



 **INOX** 8025431157385

PVD  **ORO-ROSA** 8025431157392

PVD  **CANNA-FUCILE** 8025431159525

CARATTERISTICHE

- **MATERIALE ACCIAIO INOX 316L / 316L STAINLESS STEEL**
- **PILETTA DI SCARICO PER LAVABO O BIDET**
DRAIN FOR WASHBASIN OR BIDET
- **INSTALLAZIONE STANDARD**
STANDARD INSTALLATION
- **FACILE PULIZIA E MANUTENZIONE**
EASY CLEANING AND MAINTENANCE
- **COMPLETAMENTE PRIVO DI PIOMBO**
COMPLETELY LEAD-FREE
- **PARTICOLARMENTE ADATTO PER AMBIENTI AD ALTO UTILIZZO O IN PROSSIMITÀ DEL MARE**
PARTICULARLY SUITABLE FOR HIGH-USE ENVIRONMENTS AND COASTAL AREAS
- **IDEALE PER STRUTTURE COME HOTEL, PISCINE PUBBLICHE, PALESTRE, AEROPORTI O BAGNI DI LOCALI CHE RICEVONO UN GRANDE FLUSSO DI UTENTI OGNI GIORNO**
IDEAL FOR FACILITIES SUCH AS HOTELS, PUBLIC POOLS, GYMS, AIRPORTS, AND HIGH-TRAFFIC RESTROOMS EXPERIENCE CONSTANT DAILY USE

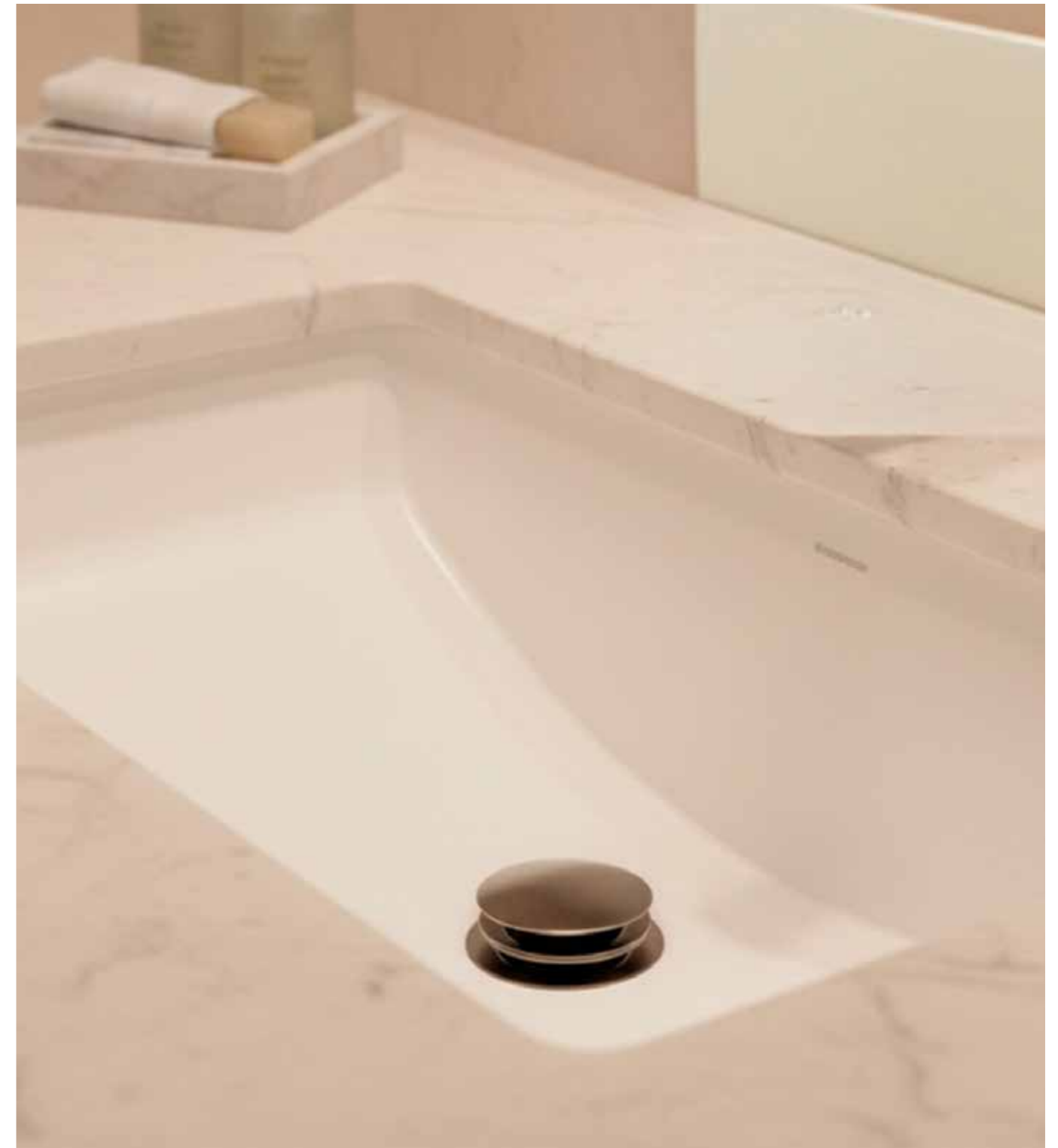
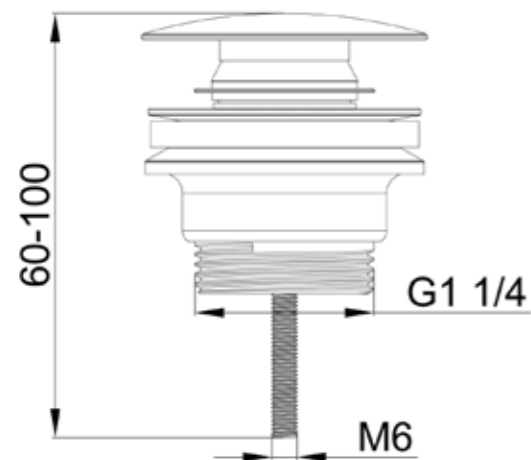

SET-DOCCINO-FLESSIBILE-WATER



STOCK

 **INOX** 8025431155947

PVD  **ORO-ROSA** 8025431156531

PVD  **CANNA-FUCILE** 8025431159358



CARATTERISTICHE

- **MATERIALE ACCIAIO INOX 316L / 316L STAINLESS STEEL**
- **SET DOCCETTA SHATTAF PER WC E BIDET**
SHATTAFF HAND SHOWER SET FOR WC AND BIDET
- **DOCCETTA CON PULSANTE**
PUSH-BUTTON HAND SHOWER
- **COLLEGAMENTO A MURO**
WALL CONNECTION
- **COMPLETAMENTE PRIVO DI PIOMBO**
COMPLETELY LEAD-FREE
- **CORPO INCASSO INCLUSO**
WALL RECESSED BODY INCLUDED
- **PARTICOLARMENTE ADATTO PER AMBIENTI AD ALTO UTILIZZO O IN PROSSIMITÀ DEL MARE**
PARTICULARLY SUITABLE FOR HIGH-USE ENVIRONMENTS AND COASTAL AREAS
- **IDEALE PER STRUTTURE COME HOTEL, PISCINE PUBBLICHE, PALESTRE, AEROPORTI O BAGNI DI LOCALI CHE RICEVONO UN GRANDE FLUSSO DI UTENTI OGNI GIORNO**
IDEAL FOR FACILITIES SUCH AS HOTELS, PUBLIC POOLS, GYMS, AIRPORTS, AND HIGH-TRAFFIC RESTROOMS EXPERIENCE CONSTANT DAILY USE

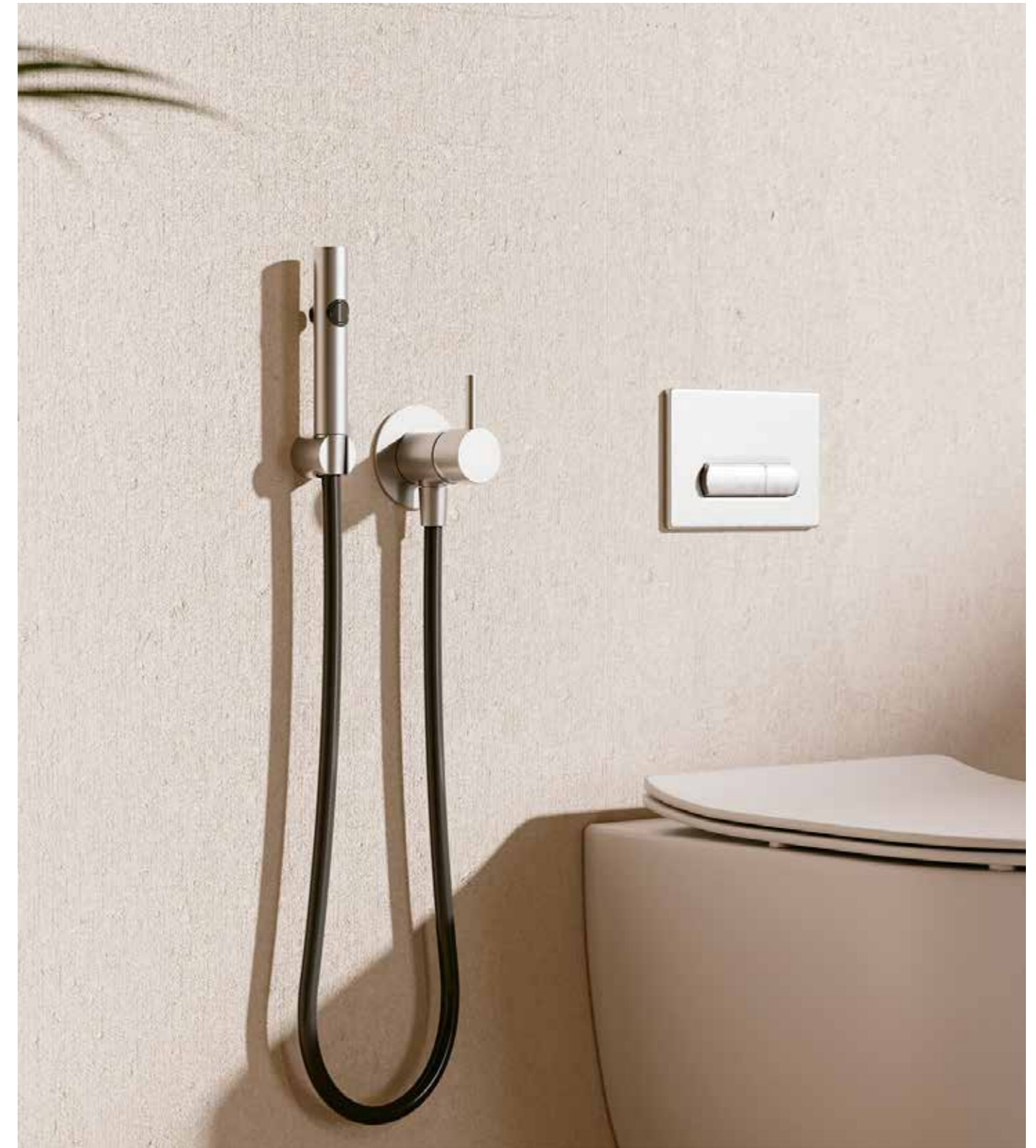
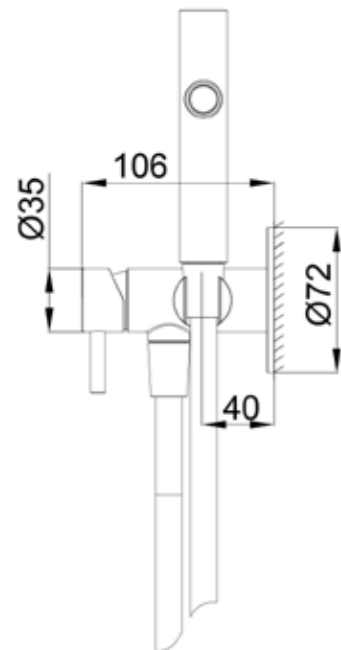

SET-MISCELATORE-MURO-DOCCINO-LEVANTE

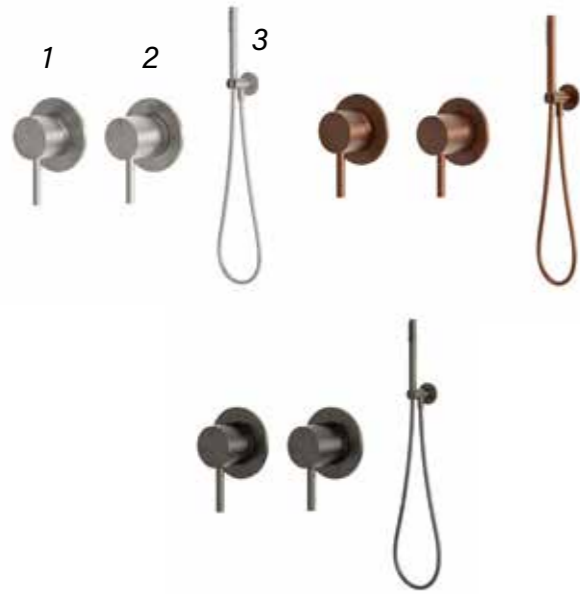

STOCK

INOX 8025431156500

PVD ORO-ROSA 8025431156517

PVD CANNA-FUCILE 8025431159365

CARATTERISTICHE

- **MATERIALE ACCIAIO INOX 316L / 316L STAINLESS STEEL**
- **DOCGETTA CON GETTO PIOGGIA**
HAND SHOWER WITH RAIN JET
- **INSTALLAZIONE A PARETE DA INCASSO**
WALL-MOUNTED BUILT-IN INSTALLATION
- **CORPO INCASSO INCLUSO**
WALL RECESSED BODY INCLUDED
- **ACQUA CALDA E FREDDA**
HOT AND COLD WATER
- **COMPLETAMENTE PRIVO DI PIOMBO**
COMPLETELY LEAD-FREE
- **COMPONENTI SET**
 1. MISCELATORE-MURO-LEVANTE (PAG 172)
 2. DEVIATORE-MURO-LEVANTE (PAG 184)
 3. DOCGETTA-FLESSIBILE-MURO-LEVANTE (PAG 202)
- **PARTICOLARMENTE ADATTO PER AMBIENTI AD ALTO UTILIZZO O IN PROSSIMITÀ DEL MARE**
PARTICULARLY SUITABLE FOR HIGH-USE ENVIRONMENTS AND COASTAL AREAS
- **IDEALE PER STRUTTURE COME HOTEL, PISCINE PUBBLICHE, PALESTRE, AEROPORTI O BAGNI DI LOCALI CHE RICEVONO UN GRANDE FLUSSO DI UTENTI OGNI GIORNO**
IDEAL FOR FACILITIES SUCH AS HOTELS, PUBLIC POOLS, GYMS, AIRPORTS, AND HIGH-TRAFFIC RESTROOMS EXPERIENCE CONSTANT DAILY USE

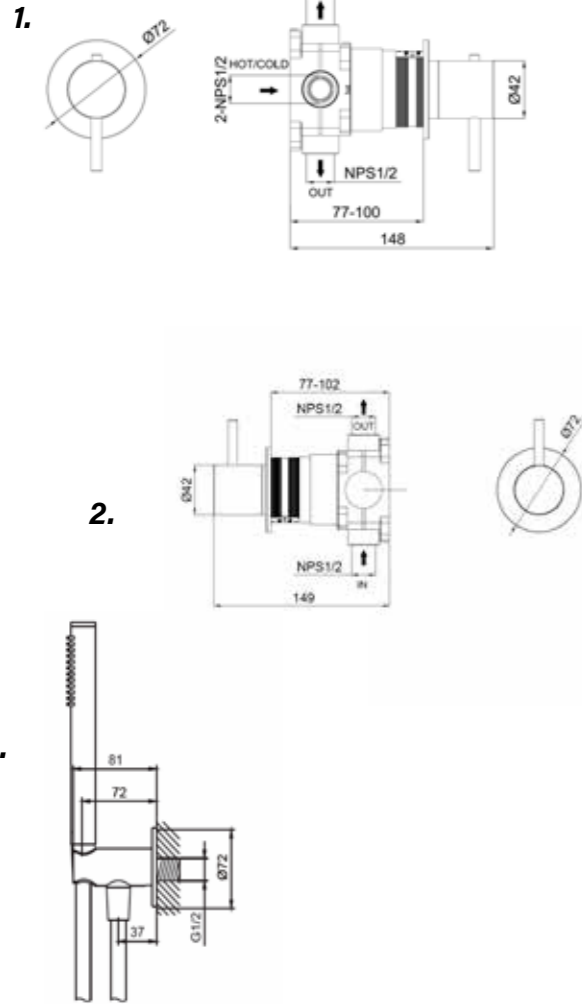

KIT-RUBINETTO-LAVANDINO-LEVANTE-PARETE

STOCK



 **INOX** 8025431155688

PVD  **ORO-ROSA** 8025431156258

PVD  **CANNA-FUCILE** 8025431159426

CARATTERISTICHE

- **MATERIALE ACCIAIO INOX 316L / 316L STAINLESS STEEL**
- **INSTALLAZIONE A INCASSO CON BOX NASCOSTO**
CONCEALED INSTALLATION WITH HIDDEN BOX
- **GETTO AERATO, DELICATO E SENZA SCHIZZI**
AERATED, GENTLE AND SPLASH-FREE WATER FLOW
- **MISCELATORE A PARETE DA INCASSO**
WALL-MOUNTED BUILT-IN MIXER
- **CORPO INCASSO INCLUSO**
WALL RECESSED BODY INCLUDED
- **ACQUA CALDA E FREDDA**
HOT AND COLD WATER
- **COMPLETAMENTE PRIVO DI PIOMBO**
COMPLETELY LEAD-FREE
- **COMPONENTI KIT**
 1. *BOCCHETTA-PARETE-LEVANTE (PAG 192)*
 2. *MISCELATORE-MURO-LEVANTE (PAG 172)*
- **PARTICOLARMENTE ADATTO PER AMBIENTI AD ALTO UTILIZZO O IN PROSSIMITÀ DEL MARE**
PARTICULARLY SUITABLE FOR HIGH-USE ENVIRONMENTS AND COASTAL AREAS
- **IDEALE PER STRUTTURE COME HOTEL, PISCINE PUBBLICHE, PALESTRE, AEROPORTI O BAGNI DI LOCALI CHE RICEVONO UN GRANDE FLUSSO DI UTENTI OGNI GIORNO**
IDEAL FOR FACILITIES SUCH AS HOTELS, PUBLIC POOLS, GYMS, AIRPORTS, AND HIGH-TRAFFIC RESTROOMS EXPERIENCE CONSTANT DAILY USE

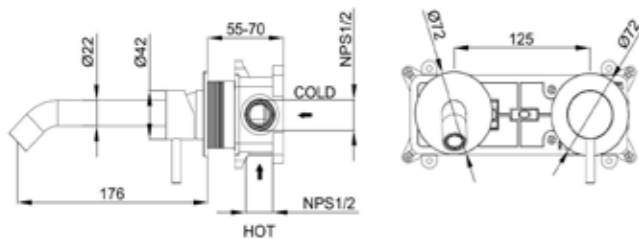

VASCHE & LAVANDINI SINED INTERNO & ESTERNO SINED BATHTUBS AND WASHBASINS INDOOR & OUTDOOR

Design essenziale, atmosfera unica

Scopri la nuova collezione di vasche da bagno e lavandini firmata SINED: soluzioni pensate per ambienti sofisticati, in cui il design si fonde con la funzionalità, esaltando colori e forme dal carattere deciso ma armonioso.

Un'estetica che invita al benessere:

Rilassarsi diventa un rituale quotidiano grazie a vasche che non sono solo oggetti d'arredo, ma esperienze. Linee pulite e materiali selezionati trasmettono una sensazione profonda di pace e quiete, trasformando ogni ambiente in una vera oasi di relax.

Tra sogno e realtà:

Le nostre forme innovative, i disegni eleganti e la versatilità d'uso - sia per interni che per esterni - rendono ogni spazio unico. Ogni elemento è studiato per adattarsi con stile a zone wellness, spa private o bagni dal gusto raffinato.

Più del minimalismo:

Minimalista, sì, ma con molto di più: le vasche e i lavabi SINED raccontano storie di design italiano, cura del dettaglio e sensibilità contemporanea. Oggetti pensati per durare nel tempo, senza rinunciare all'estetica.

Descrizione del Materiale

Tutte le vasche da bagno SINED sono realizzate in **Seiko Hydroaluminite**, un minerale composito ad alte prestazioni. Questo materiale innovativo garantisce un'elevata resistenza, una superficie liscia e vellutata al tatto, oltre a un'eccellente capacità di isolamento termico. A differenza dei materiali tradizionali, non risulta mai freddo e mantiene l'acqua calda molto più a lungo, migliorando il comfort e l'efficienza energetica. La superficie non porosa è inoltre antibatterica e facile da pulire, ideale per ambienti bagno moderni e igienici.

Essential design, unique atmosphere

Discover the new collection of SINED bathtubs and washbasins: solutions designed for sophisticated spaces, where design blends seamlessly with functionality, enhancing bold yet harmonious shapes and colors.

An aesthetic that invites well-being

Relaxation becomes a daily ritual thanks to bathtubs that are not just furnishings, but experiences. Clean lines and carefully selected materials convey a deep sense of peace and tranquility, transforming every space into a true oasis of relaxation.

Between dream and reality

Our innovative shapes, elegant designs, and versatile use — for both indoor and outdoor settings — make each environment unique. Every element is crafted to complement wellness areas, private spas, or bathrooms with refined taste.

More than minimalist

Minimalist, yes — but so much more: SINED bathtubs and washbasins tell a story of Italian design, attention to detail, and contemporary sensibility. Pieces made to last, without compromising on beauty.

Material Description

All SINED bathtubs are made of **Seiko Hydroaluminite**, a high-performance composite mineral. This innovative material offers exceptional durability, a smooth and velvety touch, and excellent thermal insulation. Unlike traditional materials, it never feels cold to the skin and keeps bathwater warm for much longer, enhancing both comfort and energy efficiency. Its non-porous surface is also antibacterial and easy to clean, making it ideal for modern, hygienic bathroom environments.



LAVANDINO- ZEFIRO

Purezza e carattere per bagni dal design ricercato

La collezione di lavandini free-standing Zefiro, nelle versioni Blu e Bianco, incarna l'incontro perfetto tra estetica sofisticata e innovazione funzionale. Con volumi pieni e linee essenziali, i lavandini Zefiro sono pensati per ambienti contemporanei dove l'arredo bagno diventa protagonista.

Realizzati in Seiko Hydroaluminite, un materiale composito dalle alte prestazioni, offrono una superficie calda al tatto, igienica e facile da pulire.

Il modello Blu, con il suo effetto trasparente, dona profondità e personalità agli spazi più audaci. Il Bianco, elegante e senza tempo, valorizza ambienti minimalisti e raffinati.

Due interpretazioni del design, una sola filosofia: SINED. Per chi sceglie materiali evoluti e forme essenziali.

Purity and character for refined bathroom design

The free-standing Zefiro collection, available in Blu and Bianco versions, represents the perfect blend of sophisticated aesthetics and functional innovation. With clean lines and solid volumes, Zefiro washbasins are designed for contemporary spaces where the bathroom becomes a statement of style.

Crafted from Seiko Hydroaluminite, a high-performance composite material, they offer a warm-to-the-touch surface that is hygienic and easy to clean.

The Blu model, with its translucent finish, adds depth and personality to bold interiors. The Bianco version, timeless and elegant, enhances minimalist and refined spaces.

Two interpretations of design, one philosophy: SINED. For those who choose advanced materials and essential forms.



LAVANDINO-TRASPARENTE-ZEFIRO-BLU

STOCK

BLU 8025431156067

*ALTRE COLORAZIONI DISPONIBILI SOLO SU
ORDINAZIONE
*OTHER COLOURS AVAILABLE ONLY UPON REQUEST



CARATTERISTICHE

- **MATERIALE MINERALE COMPOSITO SEIKO HYDROALLUMINITE**
SEIKO HYDROALLUMINITE COMPOSITE MINERAL MATERIAL
- **LAVABO FREESTANDING**
FREE-STANDING WASHBASIN
- **SUPERFICIE NON POROSA E ANTIBATTERICA**
NON-POROUS, ANTIBACTERIAL SURFACE
- **ALTA RESISTENZA A GRAFFI, URTI E AGENTI CHIMICI**
HIGH RESISTANCE TO SCRATCHES, IMPACTS AND CHEMICALS
- **SUPERFICIE CALDA E PIACEVOLE AL TATTO**
WARM, SOFT-TOUCH SURFACE
- **DIMENSIONI / DIMENSIONS 45X45X90 CM**
- **ADATTO PER USO INTERNO ED ESTERNO**
SUITABLE FOR INDOOR AND OUTDOOR USE
- **GARANZIA 5 ANNI / 5-YEAR WARRANTY**

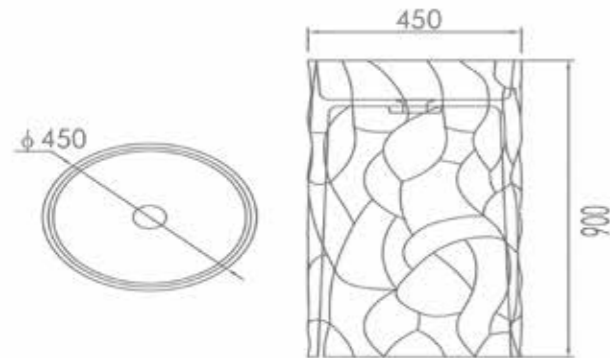

LAVANDINO-ZEFIRO-BIANCO



STOCK

BIANCO 8025431156074 *

**DISPONIBILI SOLO SU ORDINAZIONE
AVAILABLE ONLY UPON REQUEST

CARATTERISTICHE

- **MATERIALE MINERALE COMPOSITO SEIKO HYDROALLUMINITE**
SEIKO HYDROALLUMINITE COMPOSITE MINERAL MATERIAL
- **LAVABO FREESTANDING**
FREE-STANDING WASHBASIN
- **SUPERFICIE NON POROSA E ANTIBATTERICA**
NON-POROUS, ANTIBACTERIAL SURFACE
- **ALTA RESISTENZA A GRAFFI, URTI E AGENTI CHIMICI**
HIGH RESISTANCE TO SCRATCHES, IMPACTS AND CHEMICALS
- **SUPERFICIE CALDA E PIACEVOLE AL TATTO**
WARM, SOFT-TOUCH SURFACE
- **DIMENSIONI / DIMENSIONS 45X45X90 CM**
- **ADATTO PER USO INTERNO ED ESTERNO**
SUITABLE FOR INDOOR AND OUTDOOR USE
- **GARANZIA 5 ANNI / 5-YEAR WARRANTY**

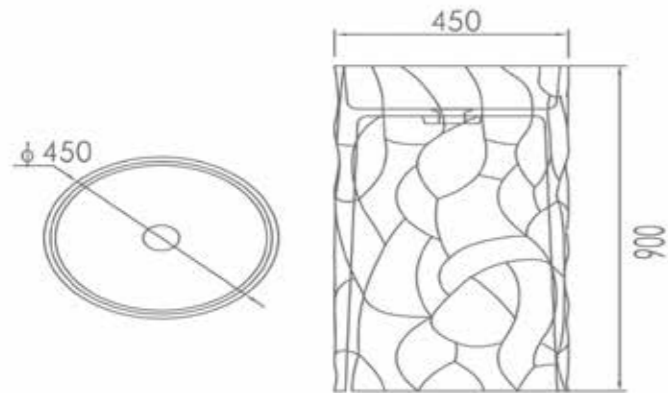

VASCA-ZEFIRO

Benessere e design in perfetta armonia

La collezione di vasche da bagno Zefiro firmata SINED, nei modelli Blu e Bianca, trasforma il bagno in un'oasi di relax ed eleganza. Con una presenza scultorea e un design minimale, queste vasche free-standing sono pensate per ambienti esclusivi dove il benessere incontra l'estetica contemporanea.

Realizzate in Seiko Hydroaluminite, garantiscono un tocco caldo e vellutato e un'eccellente capacità di mantenere il calore dell'acqua più a lungo rispetto alle vasche tradizionali.

La Zefiro Blu, con la sua finitura trasparente, è perfetta per spazi moderni e dal carattere deciso. La Zefiro Bianca, invece, con il suo bianco puro, porta equilibrio e raffinatezza negli ambienti più classici o minimal.

Due stili distinti, una sola visione: SINED. Per chi cerca comfort, innovazione e bellezza in ogni dettaglio.

Wellness and design in perfect harmony

The Zefiro bathtub collection by SINED, featuring the Blu and Bianca models, transforms the bathroom into a sanctuary of relaxation and elegance. With their sculptural presence and minimalist design, these free-standing bathtubs are conceived for high-end interiors where wellness meets contemporary aesthetics.

Made from advanced Seiko Hydroaluminite, they ensure a warm, velvety touch and exceptional thermal retention, keeping water hot longer than conventional tubs.

The Zefiro Blu impresses with its bold, translucent finish—ideal for modern and expressive environments. The Zefiro Bianca, with its pure white tone, brings timeless grace and balance to more classic or minimalist spaces.

Two distinctive styles, one vision: SINED. For those who embrace comfort, innovation, and beauty in every detail.



VASCA-TRASPARENTE-ZEFIRO-BLU



STOCK

150 CM 8025431158207 *

160 CM 8025431159280 *

170 CM 8025431156029

*ALTRE COLORAZIONI E MISURE DISPONIBILI SOLO
SU ORDINAZIONE

*OTHER COLOURS AND MEASURES AVAILABLE ONLY
UPON REQUEST

CARATTERISTICHE

- **MATERIALE MINERALE COMPOSITO SEIKO HYDROALLUMINITE**
SEIKO HYDROALLUMINITE COMPOSITE MINERAL MATERIAL
- **VASCA FREESTANDING**
FREE-STANDING BATHTUB
- **SUPERFICIE NON POROSA, LISCIA E FACILE DA PULIRE**
NON-POROUS, SMOOTH AND EASY-TO-CLEAN SURFACE
- **ALTA RESISTENZA A USURA, URTI E AGENTI CHIMICI**
HIGH RESISTANCE TO WEAR, IMPACTS AND CHEMICALS
- **SUPERFICIE CALDA E PIACEVOLE AL TATTO**
WARM, SOFT-TOUCH SURFACE
- **OTTIME PROPRIETÀ TERMICHE, MANTIENE IL CALORE PIÙ A LUNGO**
EXCELLENT THERMAL PROPERTIES, RETAINS HEAT LONGER
- **DIMENSIONI / DIMENSIONS 170X80X55 CM**
- **ADATTA PER USO INTERNO ED ESTERNO**
SUITABLE FOR INDOOR AND OUTDOOR USE
- **GARANZIA 5 ANNI / 5-YEAR WARRANTY**

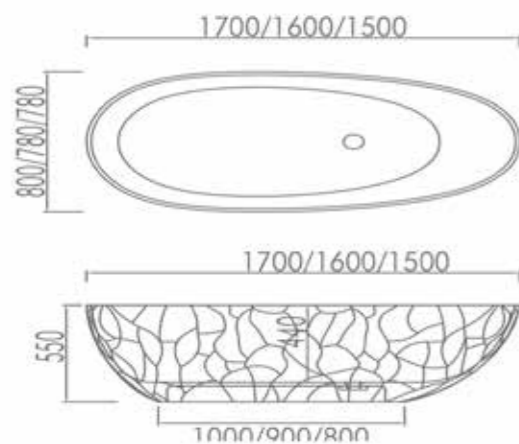

VASCA-TRASPARENTE-ZEFIRO-ROSSA-TONDA-140

STOCK

ROSSA 8025431156340 *

*DISPONIBILI SOLO SU ORDINAZIONE
*AVAILABLE ONLY UPON REQUEST



CARATTERISTICHE

- **MATERIALE MINERALE COMPOSITO SEIKO HYDROALLUMINITE**
SEIKO HYDROALLUMINITE COMPOSITE MINERAL MATERIAL
- **VASCA FREESTANDING TONDA**
ROUND FREE-STANDING BATHTUB
- **SUPERFICIE NON POROSA, LISCIA E FACILE DA PULIRE**
NON-POROUS, SMOOTH AND EASY-TO-CLEAN SURFACE
- **ALTA RESISTENZA A USURA, URTI E AGENTI CHIMICI**
HIGH RESISTANCE TO WEAR, IMPACTS AND CHEMICALS
- **SUPERFICIE CALDA E PIACEVOLE AL TATTO**
WARM, SOFT-TOUCH SURFACE
- **OTTIME PROPRIETÀ TERMICHE, MANTIENE IL CALORE PIÙ A LUNGO**
EXCELLENT THERMAL PROPERTIES, RETAINS HEAT LONGER
- **DIMENSIONI / DIMENSIONS Ø140X55 CM**
- **ADATTA PER USO INTERNO ED ESTERNO**
SUITABLE FOR INDOOR AND OUTDOOR USE
- **GARANZIA 5 ANNI / 5-YEAR WARRANTY**

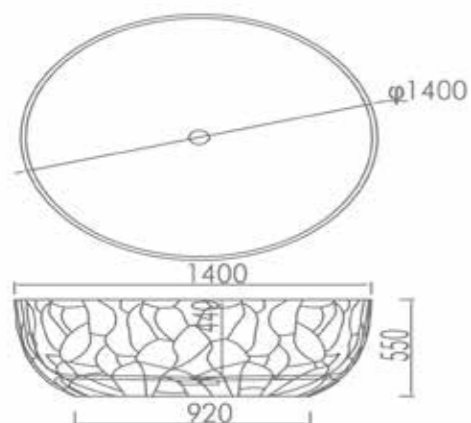

VASCA-ZEFIRO-BIANCA

STOCK

150 CM 8025431159297 *

160 CM 8025431159303 *

170 CM 8025431156043

*DISPONIBILI SOLO SU ORDINAZIONE
*AVAILABLE ONLY UPON REQUEST



CARATTERISTICHE

- **MATERIALE MINERALE COMPOSITO SEIKO HYDROALLUMINITE**
SEIKO HYDROALLUMINITE COMPOSITE MINERAL MATERIAL
- **VASCA FREESTANDING TONDA**
ROUND FREE-STANDING BATHTUB
- **SUPERFICIE NON POROSA, LISCIA E FACILE DA PULIRE**
NON-POROUS, SMOOTH AND EASY-TO-CLEAN SURFACE
- **ALTA RESISTENZA A USURA, URTI E AGENTI CHIMICI**
HIGH RESISTANCE TO WEAR, IMPACTS AND CHEMICALS
- **SUPERFICIE CALDA E PIACEVOLE AL TATTO**
WARM, SOFT-TOUCH SURFACE
- **OTTIME PROPRIETÀ TERMICHE, MANTIENE IL CALORE PIÙ A LUNGO**
EXCELLENT THERMAL PROPERTIES, RETAINS HEAT LONGER
- **DIMENSIONI / DIMENSIONS 170X80X55 CM**
- **ADATTA PER USO INTERNO ED ESTERNO**
SUITABLE FOR INDOOR AND OUTDOOR USE
- **GARANZIA 5 ANNI / 5-YEAR WARRANTY**

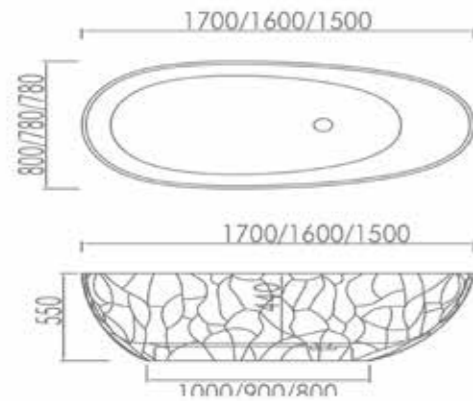

VASCA-ZEFIRO-BIANCA-TONDA-140

STOCK

BIANCO 8025431156050 *

*DISPONIBILI SOLO SU ORDINAZIONE
*AVAILABLE ONLY UPON REQUEST



CARATTERISTICHE

- **MATERIALE MINERALE COMPOSITO SEIKO HYDROALLUMINITE**
SEIKO HYDROALLUMINITE COMPOSITE MINERAL MATERIAL
- **VASCA FREESTANDING TONDA**
ROUND FREE-STANDING BATHTUB
- **SUPERFICIE NON POROSA, LISCIA E FACILE DA PULIRE**
NON-POROUS, SMOOTH AND EASY-TO-CLEAN SURFACE
- **ALTA RESISTENZA A USURA, URTI E AGENTI CHIMICI**
HIGH RESISTANCE TO WEAR, IMPACTS AND CHEMICALS
- **SUPERFICIE CALDA E PIACEVOLE AL TATTO**
WARM, SOFT-TOUCH SURFACE
- **OTTIME PROPRIETÀ TERMICHE, MANTIENE IL CALORE PIÙ A LUNGO**
EXCELLENT THERMAL PROPERTIES, RETAINS HEAT LONGER
- **DIMENSIONI / DIMENSIONS Ø140X55 CM**
- **ADATTA PER USO INTERNO ED ESTERNO**
SUITABLE FOR INDOOR AND OUTDOOR USE
- **GARANZIA 5 ANNI / 5-YEAR WARRANTY**

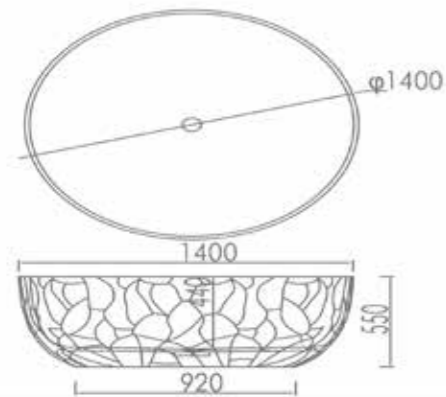

DOCCE LUNA IN ALLUMINIO

ALUMINIUM LUNA SHOWERS

La collezione LUNA-ALU di SINED ridefinisce il concetto di doccia da esterno con una gamma di modelli che combinano design contemporaneo, materiali ad alte prestazioni e funzionalità pensate per ogni esigenza. Realizzate in alluminio anodizzato, le docce LUNA-ALU si distinguono per l'elevata resistenza alla corrosione, la leggerezza strutturale e la sofisticata finitura estetica, ideale sia per installazioni residenziali che professionali.

SINED's LUNA-ALU collection redefines the outdoor shower concept with a range of models that combine contemporary design, high-performance materials and functionality designed for every need. Made of anodised aluminium, the LUNA-ALU showers stand out for their high resistance to corrosion, their structural lightness and their sophisticated aesthetic finish, ideal for both residential and professional installations.



SINED: docce con brevetto esclusivo e soluzioni anche in alluminio, per ogni esigenza.

Oltre alla prestigiosa linea in acciaio inox 316L, SINED propone anche una gamma di docce in alluminio verniciato, pensata per offrire un'alternativa di qualità eccellente con un rapporto qualità-prezzo altamente competitivo.

Queste docce sono realizzate con design brevettato da SINED per il collegamento idrico, che garantisce facilità d'installazione, affidabilità e pulizia estetica, senza compromessi sulla funzionalità.

Disponibili in due configurazioni pratiche e funzionali. Versione acqua calda e fredda: dotata di miscelatore per un controllo preciso della temperatura.

Versione solo fredda con temporizzatore: ideale per contesti pubblici, sportivi o balneari, dove sono richieste praticità e risparmio idrico.

Perché scegliere l'alluminio SINED? È un materiale leggero ma resistente, trattato con verniciatura a polvere anti-UV e anticorrosione.

Design italiano, elegante e minimalista, adatto a ogni tipo di ambiente esterno.

Manutenzione semplice e lunga durata anche in condizioni climatiche sfavorevoli.

Grazie alla combinazione tra ingegneria brevettata, qualità costruttiva e convenienza, le docce in alluminio SINED rappresentano la soluzione ideale per progetti residenziali e collettivi.

SINED: showers with exclusive patent and solutions also in aluminium, for every need.

In addition to the prestigious 316L stainless steel line, SINED also offers a range of painted aluminium showers, designed to offer an excellent quality alternative with a highly competitive price-quality ratio.

These showers are made with SINED's patented water connection design, which guarantees ease of installation, reliability and aesthetic cleanliness, without compromising on functionality.

Available in two practical and functional configurations. Hot and cold water version: equipped with a mixer for precise temperature control.

Cold only version with timer: ideal for public, sporting or seaside settings, where practicality and water saving are required.

Why choose aluminium SINED? It is a light weight but resistant material, treated with anti-UV and anti-corrosion powder coating.

Italian design, elegant and minimalist, suitable for any outdoor environment.

Easy maintenance and long life even in unfavourable weather conditions.

Thanks to the combination of patented engineering, construction quality and affordability, SINED aluminium showers are the ideal solution for residential and community projects.

DOCCIA LUNA-ALU

Eleganza essenziale per ogni spazio esterno

La doccia LUNA-ALU incarna la purezza del design italiano con una struttura dalle linee pulite e materiali di alta qualità. Realizzata in alluminio anodizzato, è ideale per chi cerca una soluzione estetica, leggera e resistente, perfetta sia per ambienti privati che per spazi comuni. Facile da installare, disponibile in versione acqua fredda o miscelata, rappresenta una scelta versatile e di grande impatto visivo. La soluzione perfetta per chi ama la discrezione unita alla raffinatezza.

Essential elegance for every outdoor space

The LUNA-ALU shower embodies the purity of Italian design, featuring clean lines and high-quality materials. Made of anodized aluminum, it is ideal for those seeking a stylish, lightweight, and durable solution, suitable for both private and shared environments. Easy to install and available in cold water or mixed water versions, it offers visual impact with maximum versatility. A perfect choice for those who value discretion and sophistication.



LUNA-ALU

STOCK

BIANCO 8025431152670

GRIGIO 8025431152830

NERO-ORO 8025431153219



CARATTERISTICHE

- **MATERIALE: ESTRUSIONE IN ALLUMINIO AA6063 / MATERIAL: EXTRUSION ALUMINIUM AA 6063**
- **UGELLI ANTICALCARE / ANTI LIMESCALE NOZZLES**
- **ACCESSORI IN ACCIAIO INOX / STAINLESS STEEL**
- **PACKAGING 125X64X23 CM**
- **GETTO D'ACQUA / WATER JET VERTICALE**
- **INCLUDE SACCA DI PROTEZIONE / PROTECTION BAG**
- **VERNICIATURA A POLVERE IN STILE AUTOMOBILISTICO / AUTOMOTIVE-STYLE POWDER COATING**
- **SOFFIONE IN ACCIAIO / STEEL SHOWER HEAD Ø20CM**
- **ACQUA CALDA E FREDDA / WATER HOT AND COLD**
- **PESO / WEIGHT 8 KG**

SISTEMA DI FISSAGGIO / FIXING SYSTEM
4 VITI / SCREWS

WORLD WIDE SINED EXCLUSIVE!
ESCLUSIVA MONDIALE SINED!

DOUBLE WATER INLET SIDE OR
BOTTOM

PREDISPOSTA PER 2 TIPI DI
COLLEGAMENTO LATERALE O
INFERIORE

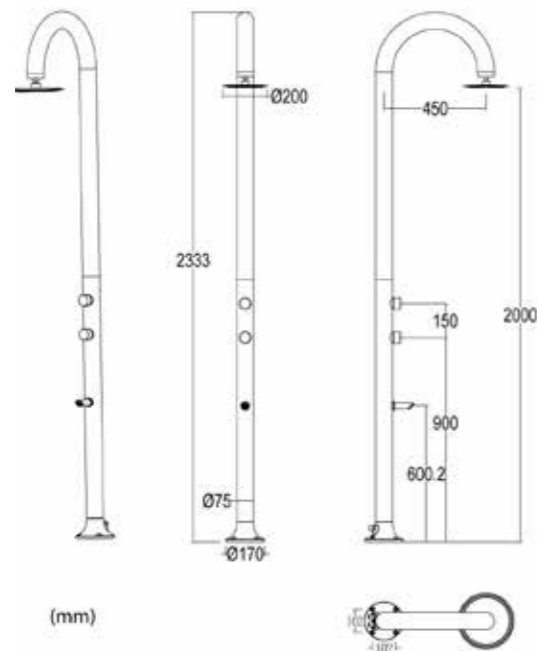
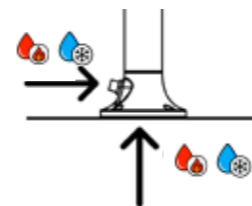

LUNA-ALU-D

STOCK

BIANCO 8025431152717

NERO-ORO 8025431153226

CARATTERISTICHE

- **MATERIALE: ESTRUSIONE IN ALLUMINIO AA6063 / MATERIAL: EXTRUSION ALUMINIUM AA 6063**
- **UGELLI ANTICALCARE / ANTI LIMESCALE NOZZLES**
- **ACCESSORI IN ACCIAIO INOX / STAINLESS STEEL**
- **PACKAGING 125X64X23 CM**
- **GETTO D'ACQUA / WATER JET VERTICALE**
- **INCLUDE SACCA DI PROTEZIONE/PROTECTION BAG**
- **ACQUA CALDA E FREDDA / WATER HOT AND COLD**
- **PESO/WEIGHT 8 KG** 
- **DOCCETTA FLESSIBILE / FLEXIBLE HANDSHOWER**
- **VERNICIATURA A POLVERE IN STILE AUTOMOBILISTICO/AUTOMOTIVE-STYLE POWDER COATING**
- **SOFFIONE IN ACCIAIO/STEEL SHOWER HEAD Ø20CM**

SISTEMA DI FISSAGGIO / FIXING SYSTEM
4 VITI / SCREWS

WORLD WIDE SINED EXCLUSIVE!
ESCLUSIVA MONDIALE SINED!

DOUBLE WATER INLET SIDE OR
BOTTOM

PREDISPOSTA PER 2 TIPI DI
COLLEGAMENTO LATERALE O
INFERIORE

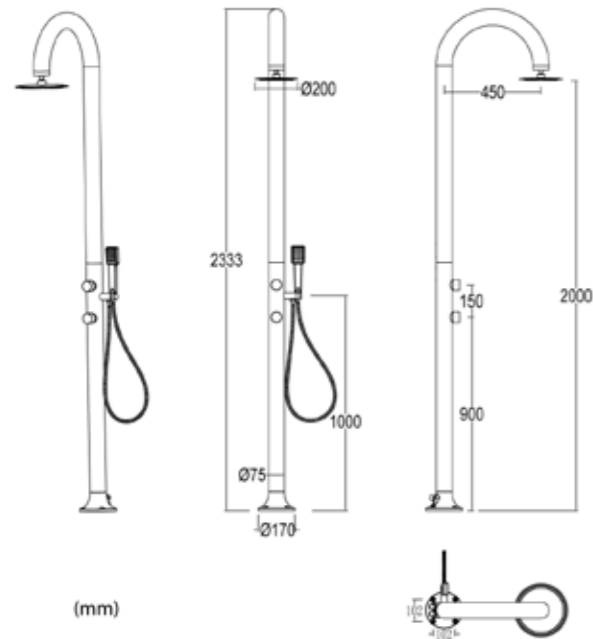
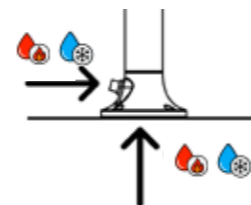

(mm)



DOCCIA LUNA-TIMER

Tecnologia e controllo per un uso sostenibile

Pensata per spazi pubblici e professionali, la LUNA-TIMER è dotata di temporizzatore a spegnimento automatico, che garantisce un uso razionale dell'acqua senza compromettere il comfort. Il corpo in alluminio anodizzato resiste alle condizioni ambientali più difficili, mantenendo inalterata la sua bellezza nel tempo. Ideale per piscine pubbliche, centri sportivi e ambienti ad alta frequentazione, dove efficienza e durata sono fondamentali. Una soluzione moderna che unisce sostenibilità e design.

Technology and control for sustainable use

Designed for public and professional spaces, the LUNA-TIMER features an automatic shut-off timer that ensures responsible water use without sacrificing comfort. Its anodized aluminum body withstands harsh environmental conditions, retaining its beauty over time. Ideal for public pools, sports centers, and high-traffic areas where efficiency and durability are essential. A modern solution that combines sustainability and refined design.



LUNA-TIMER



STOCK

BIANCA 8025431152915

GRIGIA 8025431152953

NERA 8025431152946

CARATTERISTICHE

- **MATERIALE: ESTRUSIONE IN ALLUMINIO AA6063**
MATERIAL: EXTRUSION ALUMINIUM AA 6063
- **UGELLI ANTICALCARE / ANTI LIMESCALE NOZZLES**
- **ACCESSORI IN ACCIAIO INOX / STAINLESS STEEL**
- **PACKAGING 125X64X23 CM**
- **GETTO D'ACQUA / WATER JET VERTICALE**
- **INCLUDE SACCA DI PROTEZIONE/PROTECTION BAG**
- **ACQUA FREDDA O PREMISCELATA / WATER COLD OR PREMIXED** 
- **PESO/WEIGHT 8 KG**
- **PULSANTE TEMPORIZZATORE / TIMER FUNCTION** 
- **VERNICIATURA A POLVERE IN STILE AUTOMOBILISTICO/AUTOMOTIVE-STYLE POWDER COATING**
- **SOFFIONE IN ACCIAIO/STEEL SHOWER HEAD Ø20CM**

SISTEMA DI FISSAGGIO / FIXING SYSTEM
4 VITI / SCREWS

WORLD WIDE SINED EXCLUSIVE!
ESCLUSIVA MONDIALE SINED!

DOUBLE WATER INLET SIDE OR
BOTTOM

PREDISPOSTA PER 2 TIPI DI
COLLEGAMENTO LATERALE O
INFERIORE

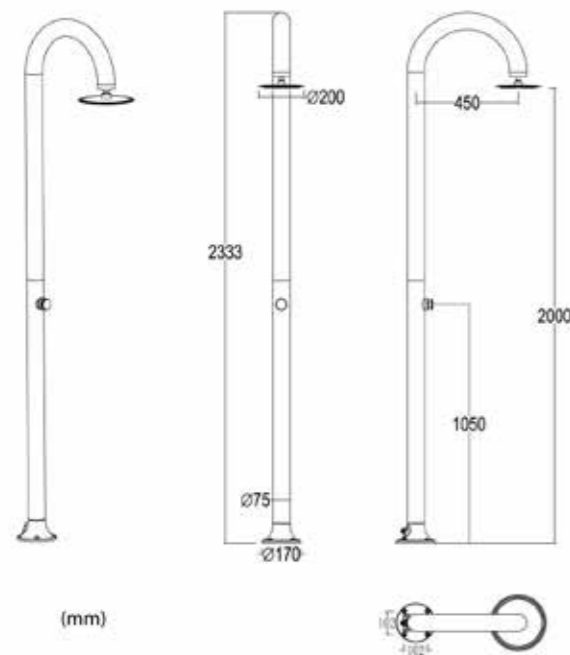
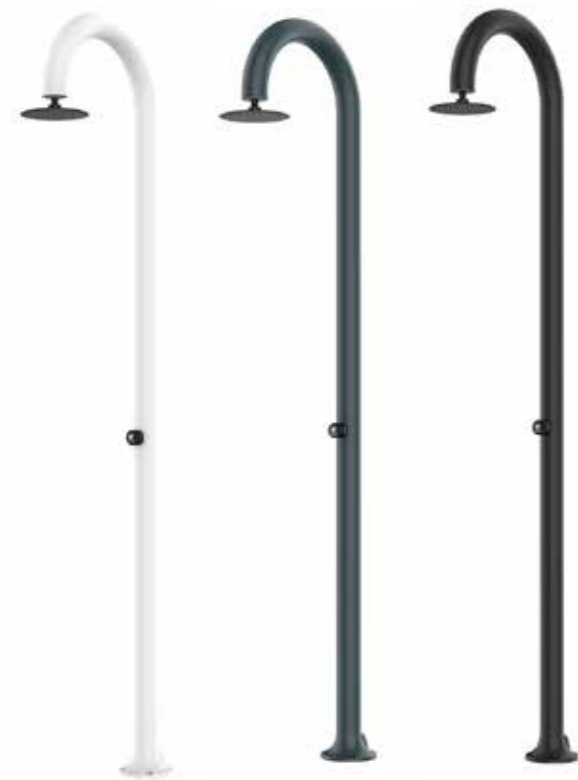
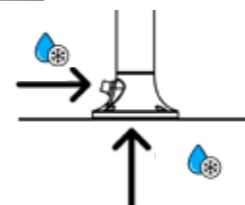

(mm)

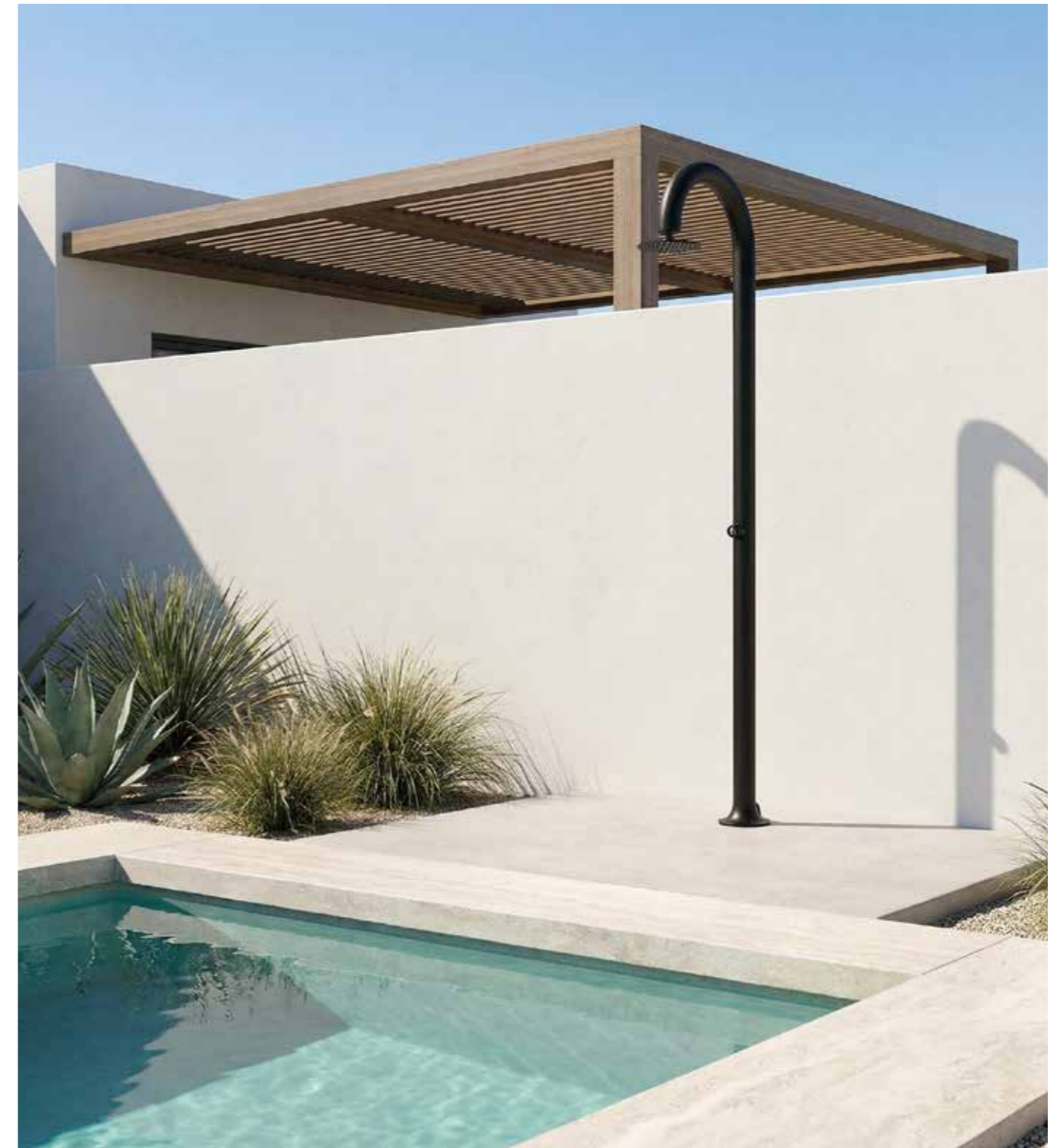

LUNA-TIMER-P



STOCK

BIANCA 8025431152922

GRIGIA 8025431152960

NERA 8025431152939

CARATTERISTICHE

- **MATERIALE: ESTRUSIONE IN ALLUMINIO AA6063 / MATERIAL: EXTRUSION ALUMINIUM AA 6063**
- **UGELLI ANTICALCARE / ANTI LIMESCALE NOZZLES**
- **ACCESSORI IN ACCIAIO INOX / STAINLESS STEEL**
- **PACKAGING 125X64X23 CM**
- **GETTO D'ACQUA / WATER JET VERTICALE**
- **INCLUDE SACCA DI PROTEZIONE/PROTECTION BAG**
- **ACQUA FREDDA O PREMISCELATA / WATER COLD OR PREMIXED** 
- **PESO/WEIGHT 8 KG**
- **PULSANTE TEMPORIZZATORE / TIMER FUNCTION** 
- **VERNICIATURA A POLVERE IN STILE AUTOMOBILISTICO/AUTOMOTIVE-STYLE POWDER COATING**
- **SOFFIONE IN ACCIAIO/STEEL SHOWER HEAD Ø20CM**

SISTEMA DI FISSAGGIO / FIXING SYSTEM
4 VITI / SCREWS

WORLD WIDE SINED EXCLUSIVE!
ESCLUSIVA MONDIALE SINED!

DOUBLE WATER INLET SIDE OR
BOTTOM

PREDISPOSTA PER 2 TIPI DI
COLLEGAMENTO LATERALE O
INFERIORE

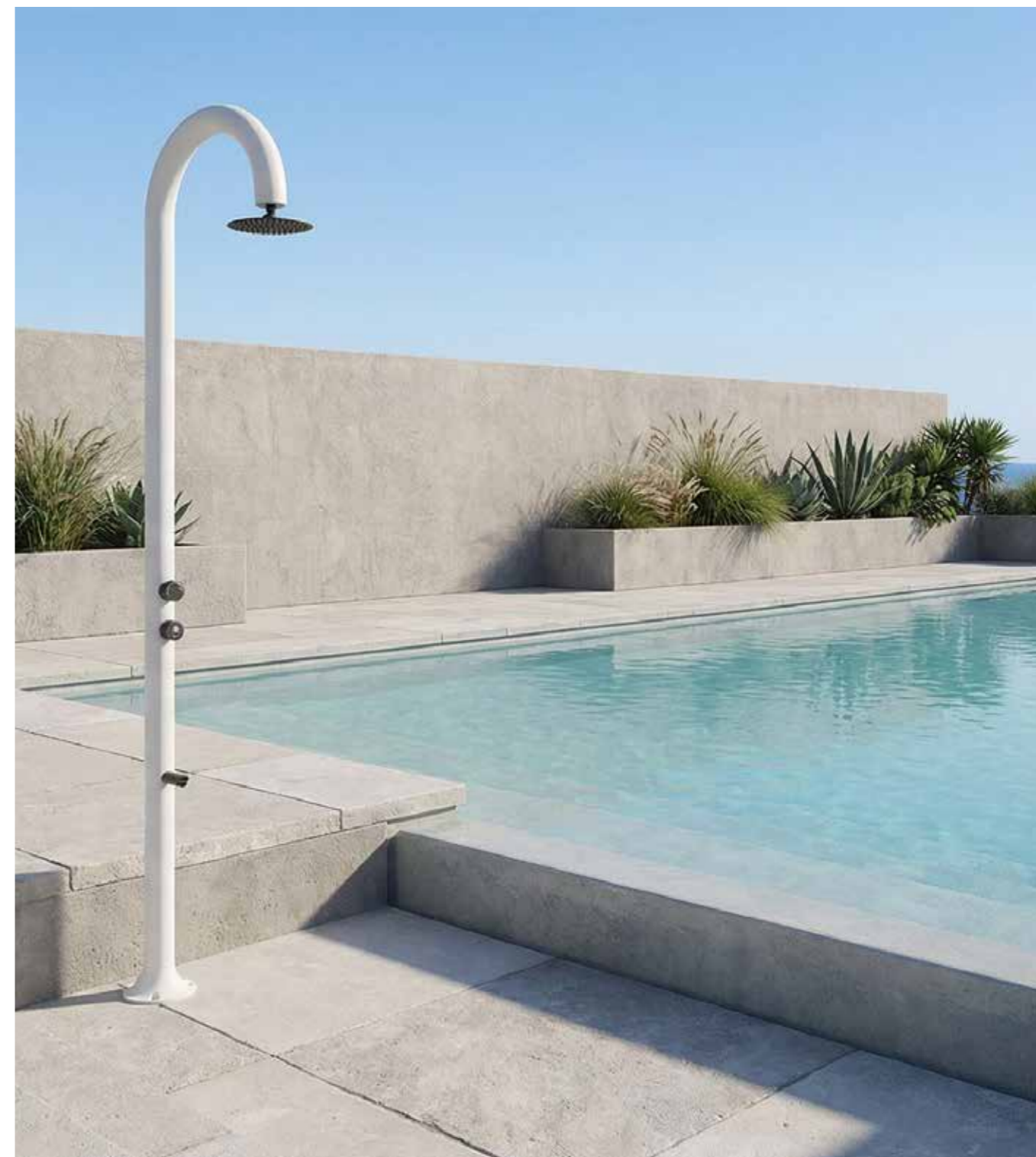
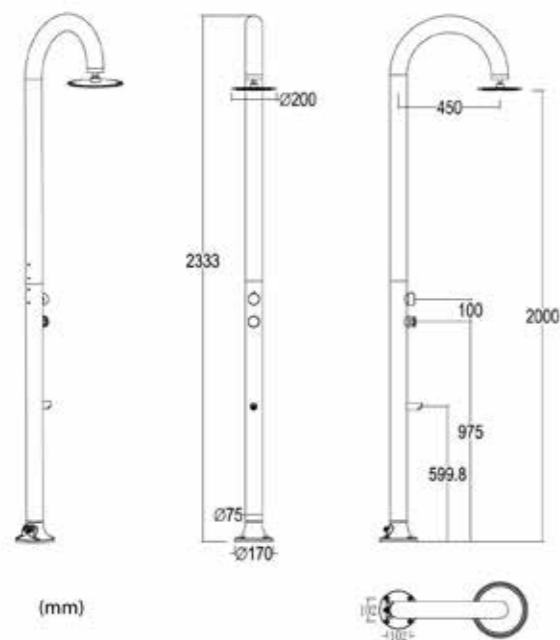
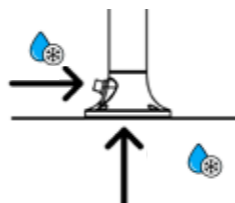

FINITURE PVD

PVD FINISHES

SCATOLA-CAMPIONI-PVD

8025431158443

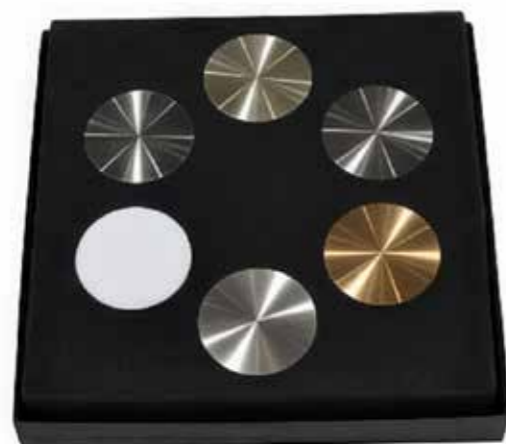

ESPOSITORI FINITURE DOCCE SINED

COLORI:



Bianco



Canna Fucile
Brushed Gun



Inox



Nero
Brushed
Black



Oro Rosa
Brushed
Rose Gold



Oro
Brushed
Gold



SCHEDE TECNICHE TECHNICAL DATA SHEET

C-BOX



SISTEMA DI FISSAGGIO RAPIDO A PAVIMENTO PER LE DOCCE INOX

Il C-BOX consente un'installazione perfetta, ed è protetto con un coperchio richiudibile quando la doccia viene smontata.

Il C-BOX deve essere installato perfettamente in bolla e fissato al suolo nel cemento con i 4 tasselli metallici in dotazione.

All'interno del C-BOX troviamo gli innesti ad attacco rapido per collegare la doccia in acciaio.

Gli attacchi rapidi posizionati alla base della doccia sono connessi con un triplo sistema di anelli OR a tenuta stagna. Tutti gli attrezzi in dotazione sono in acciaio.

QUICK FLOOR ATTACHMENT SYSTEM FOR STAINLESS STEEL SHOWERS

The C-BOX allows perfect installation, and is protected with a lockable cover when the shower is dismantled.

The C-BOX must be installed perfectly level and fixed to the ground in concrete with the 4 metal anchors provided.

Inside the C-BOX are quick-connect couplings for connecting the steel shower.

The quick couplings at the base of the shower are connected with a triple system of watertight O-rings. All tools supplied are made of steel.

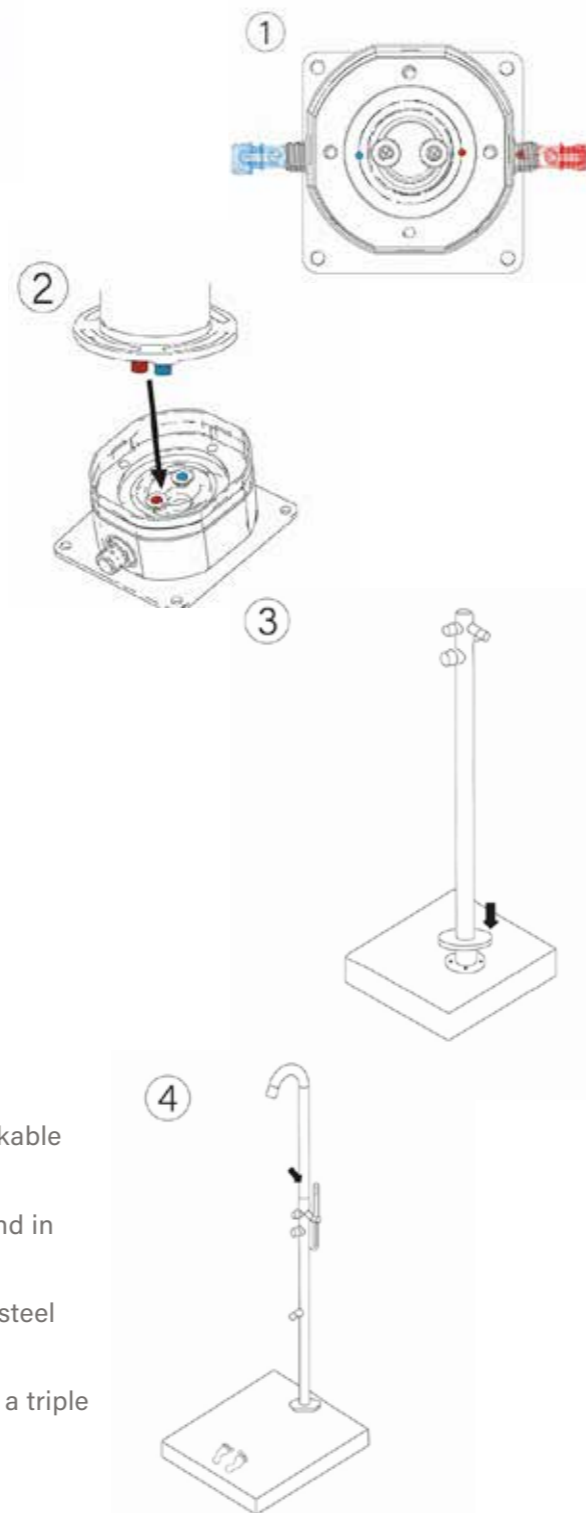

SCHEDE TECNICHE TECHNICAL DATA SHEET

SUPER-BOX



SISTEMA DI FISSAGGIO RAPIDO A PAVIMENTO PER LE DOCCE MULTI TESTA

QUICK FLOOR FASTENING SYSTEM FOR MULTI-HEAD SHOWERS

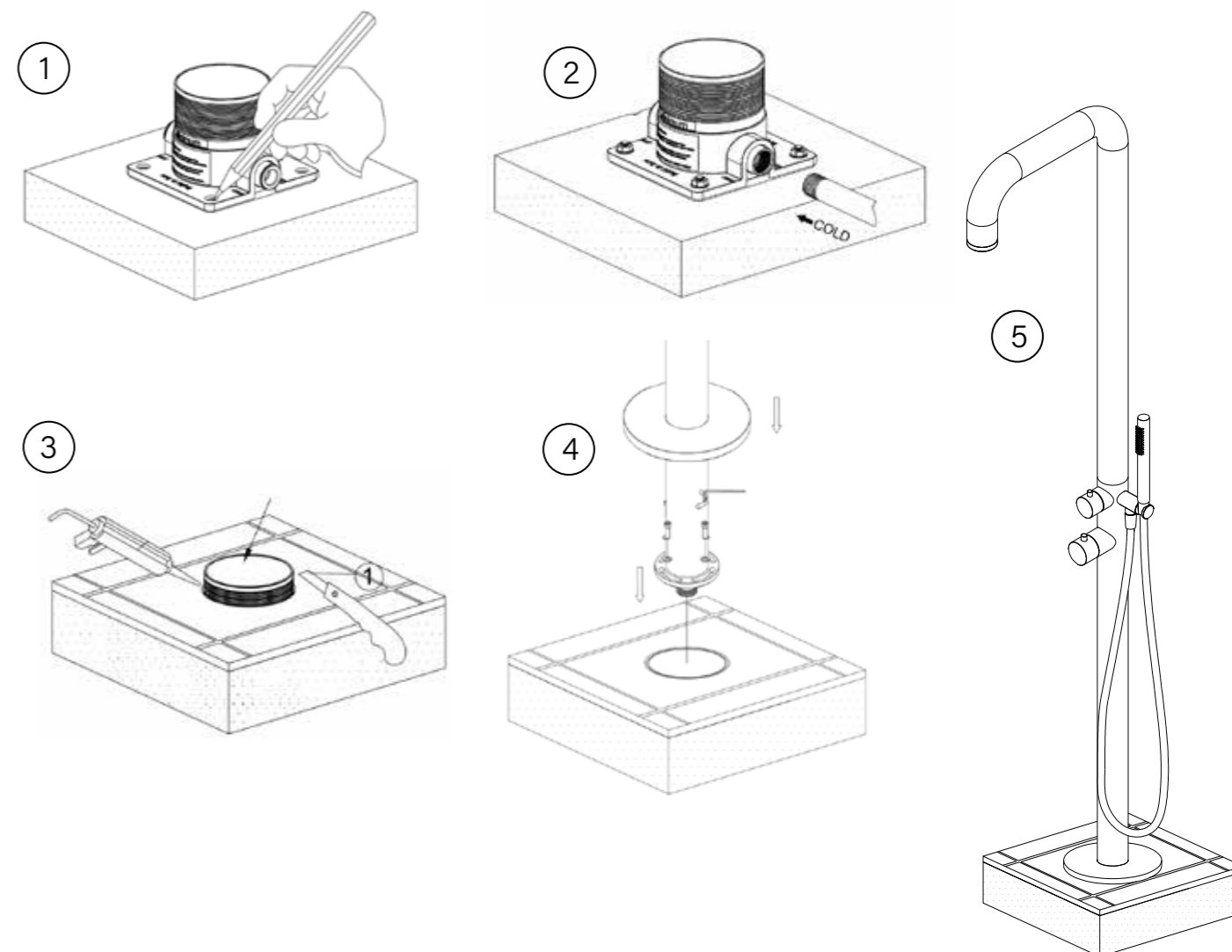

SCHEDE TECNICHE TECHNICAL DATA SHEET

C-BOX-MINI

SISTEMA DI FISSAGGIO A
SCOMPARSA IN ACCIAIO INOX
316L

CONCEALED FIXING SYSTEM IN
316L STAINLESS STEEL

Il C-BOX-MINI è un sistema di fissaggio a scomparsa realizzato interamente in acciaio inox 316L, resistente alla corrosione e ideale per ambienti esterni e marini. Progettato specificamente per le docce e fontanelle della serie SINED Levante, il mini C-BOX permette l'installazione incassata a pavimento, garantendo una base solida e duratura.

Grazie al suo design compatto e discreto, consente di nascondere gli elementi di fissaggio, migliorando l'estetica complessiva del prodotto e facilitando le operazioni di montaggio e manutenzione.

The C-BOX-MINI is a concealed fixing system made entirely of corrosion-resistant 316L stainless steel, ideal for outdoor and marine environments. Designed specifically for the SINED Levante series of showers and drinking fountains, the mini C-BOX allows for recessed installation in the floor, guaranteeing a solid and durable base.

Thanks to its compact and discreet design, it allows the fixing elements to be concealed, improving the overall aesthetics of the product and facilitating installation and maintenance operations.



SCHEDE TECNICHE TECHNICAL DATA SHEET

FISSAGGIO DOCCE SPECIALE:

Nora, Teulada, Santadi

DUE MODI PER COLLEGARE L'ACQUA: LATERALE O INFERIORE TWO WAYS TO CONNECT THE WATER: SIDE OR BOTTOM

Le docce speciali SINED, come il modello NORA, sono progettate per offrire massima flessibilità di installazione, adattandosi a diverse esigenze progettuali sia in ambito outdoor che contract. Il sistema di fissaggio e collegamento dell'acqua prevede due modalità alternative, entrambe integrate nella struttura della doccia:

SINED special showers, such as the NORA model, are designed to offer maximum installation flexibility, adapting to different design requirements in both outdoor and contract settings. The fixing and water connection system offers two alternative methods, both integrated into the shower structure:

COLLEGAMENTO LATERALE / SIDE CONNECTIONS 1/2"

La soluzione più comune prevede un **attacco laterale da 1/2"**, compatibile con gli impianti idraulici standard. Questa configurazione consente:

The most common solution involves a 1/2" side connection, compatible with standard plumbing systems. This configuration allows for:

- un'installazione rapida / quick installation
- un facile accesso alla linea dell'acqua / easy access to the water line
- un fissaggio a parete o su superficie rigida senza necessità di predisposizioni a pavimento / wall or rigid surface mounting without the need for floor preparations

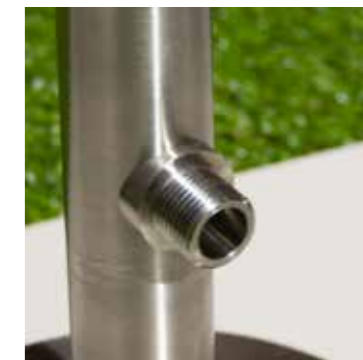

COLLEGAMENTO A PAVIMENTO / SIDE CONNECTIONS 1/2"

In alternativa, la doccia può essere installata con **ingresso dell'acqua dal pavimento**.

In questo caso:

Alternatively, the shower can be installed with water inlet from the floor. In this case:

- il fissaggio avviene tramite **4 viti di ancoraggio** alla base / it is secured by means of 4 anchoring screws at the base
- la connessione idrica risulta **completamente nascosta**, garantendo un'estetica più pulita e minimale / the water connection is completely concealed, ensuring a cleaner, more minimalist look
- è ideale per installazioni su platea in cemento, bordo piscina o superfici dedicate / It is ideal for installation on concrete slabs, pool edges or dedicated surfaces.



SCHEDE TECNICHE TECHNICAL DATA SHEET

SISTEMA DI FISSAGGIO DOPPIO PRESENTE NELLE DOCCIA

DOUBLE FASTENING SYSTEM PRESENT IN MOON SHOWERS

DUE MODI PER COLLEGARE L'ACQUA: LATERALE O INFERIORE

Il modello LUNA si distingue per un sistema di ingressi acqua avanzato, con separazione tra acqua calda e fredda che garantisce maggiore efficienza, sicurezza e comfort. Il controllo indipendente delle temperature consente di adattare l'esperienza della doccia alle preferenze personali e alle condizioni climatiche. Inoltre, la possibilità di scegliere ingressi laterali o inferiori offre grande flessibilità di installazione, facilitando l'integrazione sia in nuovi progetti sia in strutture esistenti, mantenendo un design pulito e funzionale.

TWO WAYS TO CONNECT THE WATER: SIDE OR BOTTOM

The LUNA model stands out for its advanced water inlet system, with separate hot and cold water connections that ensure greater efficiency, safety, and comfort. Independent temperature control allows users to tailor the shower experience to personal preferences and weather conditions. In addition, the option of lateral or bottom water inlets provides high installation flexibility, making the shower easy to integrate into both new projects and existing structures while preserving a clean and functional design.

SINED IN ESCLUSIVA MONDIALE!
DOPPIO INGRESSO ACQUA
LATERALE O INFERIORE

SINED WORLD WIDE EXCLUSIVE!
DOUBLE WATER INLET
SIDE OR BOTTOM

INSTALLAZIONE SEMPLICE
SOLO 4 VITI

SIMPLE INSTALLATION
ONLY 4 SCREWS

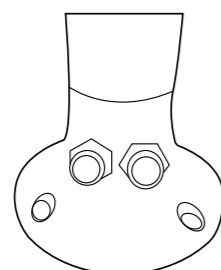
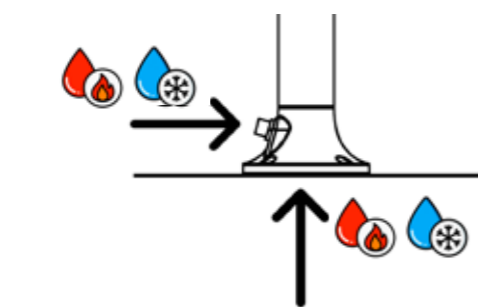

DOCCE LUNA



SPECIFICHE E COMPONENTI DELLA RUBINETTERIA SPECIFICATIONS AND COMPONENTS OF TAPS AND FAUCETS

RUBINETTO DA CUCINA CON CANNA GIREVOLE SWIVEL KITCHEN TAP

Rubinetto da cucina con canna girevole per la massima libertà di movimento e comfort d'uso, ideale per lavelli ampi o a doppia vasca. Realizzato in acciaio inox AISI 316L, assicura resistenza, igiene e durata nel tempo.

Kitchen tap with swivel spout for maximum freedom of movement and comfort of use, ideal for large or double sinks. Made of AISI 316L stainless steel, it ensures resistance, hygiene and durability.

SHATTAF (DOCCETTA IGIENICA) SHATTAF

Lo shattaf è una doccetta igienica manuale con comando a pressione per una pulizia personale efficace dopo l'uso del WC, riducendo l'uso della carta. Una soluzione pratica e igienica per bagni contemporanei.

The shattaf is a manual hygienic shower with a pressure control for effective personal cleaning after using the toilet, reducing the use of paper. A practical and hygienic solution for contemporary bathrooms.

CARTUCCIA CERTIFICATA WANHAI WANHAI CERTIFIED CARTRIDGE

I nostri rubinetti da cucina sono dotati di cartucce ceramiche certificate Wanhai, che garantiscono controllo preciso, chiusura totale senza perdite e reale water saving, assicurando qualità e affidabilità nel tempo.

Our kitchen taps are equipped with Wanhai certified ceramic cartridges, which guarantee precise control, total closure without leaks and real water saving, ensuring quality and reliability over time.

MODELI DI FLUSSO STREAM PATTERNS

Gli aeratori NEOPERL modellano il flusso dell'acqua in diverse modalità; il flusso aerato miscela aria e acqua creando un getto morbido, piacevole e visivamente abbondante. Una soluzione che unisce comfort d'uso ed efficienza.

NEOPERL aerators shape the water flow in different ways; the aerated flow mixes air and water, creating a soft, pleasant and visually abundant jet. A solution that combines comfort of use and efficiency.

STRUMENTO PER SOSTITUIRE L'AERATORE NEOPERL TOOL FOR REPLACE THE AERATOR

Il rubinetto è dotato di aeratore Neoperl ad alte prestazioni, che miscela aria e acqua per un getto morbido, uniforme e confortevole, con consumi ottimizzati. Incluso l'accessorio per la sostituzione dell'aeratore, a garanzia di qualità costante nel tempo.

The tap is equipped with a high-performance Neoperl aerator, which mixes air and water for a soft, uniform and comfortable flow, with optimised consumption. Includes an accessory for replacing the aerator, guaranteeing consistent quality over time.



SINED SHOWROOM



Sined V.O S.L.U

Via Trajana 50-55, Sant Martí, Nave 28.
08020, Barcelona

UFFICIO SINED SINED'S OFFICE



Sined V.O S.L.U

Via Trajana 50-55, Sant Martí, Nave 28.
08020, Barcelona



SINED NEL MONDO

ALCUNE FIERE ED EVENTI DEL 2025



“Design Acqua by SINED è presente in progetti in tutto il mondo, portando l’innovazione italiana ovunque”

“Design Acqua by SINED is present in projects worldwide, bringing Italian innovation everywhere.”

I nostri social network:



@sined.showers



@sined_italia



MY PLANT & GARDEN 2025

Roh-Milan, Italia



PISCINA BARCELONA 2025

Barcelona, Spain



MARBELLA HOME MEETING 2025

Marbella, Spain



MÉXICO HOSPITALITY 2025

Jalisco, Mexico

CONDIZIONI DI FORNITURA

Crediamo nella qualità e nella durata dei nostri prodotti. Per questo motivo, offriamo una garanzia di 3 anni su tutti i prodotti a marchio SINED.

1. INFORMAZIONI GENERALI

Garanzia del Produttore

- Per “Consumatore” si intende qualsiasi persona fisica o giuridica che sia proprietaria del prodotto e non lo abbia acquistato per rivenderlo o installarlo a terzi nell’esercizio di un’attività commerciale o professionale.
- Per “Cliente Iniziale” o “Rivenditore” si intende il primo acquirente di prodotti a marchio SINED, sia esso un rivenditore o un professionista che rivende o installa il prodotto per terzi nell’ambito della propria attività.

2. PERIODO DI GARANZIA

Il periodo di garanzia decorre dalla data di acquisto indicata sulla fattura originale del Cliente Iniziale (Rivenditore).

La garanzia ha una durata di **3 anni** a partire dalla suddetta data, a condizione che:

- La fattura originale venga conservata e mostrata su richiesta;
- Il prodotto sia stato installato e mantenuto da personale qualificato, secondo le istruzioni e le normative in vigore.

3. GARANZIA

Per attivare una richiesta di assistenza in garanzia il Consumatore deve:

- Notificare per iscritto il difetto a SINED o al Rivenditore autorizzato;
- Presentare la fattura originale che dimostri la data di acquisto e la validità della garanzia;
- Assicurarsi che l’installazione e la manutenzione siano state effettuate da personale qualificato.

4. LIMITAZIONI DELLA GARANZIA

La garanzia **non copre**:

- Parti soggette a normale usura (cartucce, guarnizioni, anelli di tenuta, pompe sapone, filtri, aeratori);
- Danni da installazione errata o da presenza di residui nelle tubature tipo sabbia o calcare.
- Danni causati da sporcizia, calcare, uso improprio, prodotti chimici aggressivi, errori di funzionamento, urti, agenti atmosferici o ambienti estremi.

5. DECADENZA DELLA GARANZIA

La garanzia **decade** nei seguenti casi:

- Danni causati da forza maggiore (es. incendi, inondazioni, gelo);
- Uso improprio o non conforme alle istruzioni d’uso;
- Installazione, manutenzione o riparazioni effettuate da personale non qualificato;
- Utilizzo di ricambi non originali SINED;
- Deterioramento da calcare, sovratensioni elettriche, fenomeni atmosferici;
- Manutenzione inadeguata o mancata osservanza delle istruzioni;

Interventi non coperti:

- Pulizia filtri;
- Pulizia aeratori;
- Rimozione del calcare da doccette, soffioni o superfici.

In caso di reclami **non fondati** (difetti non imputabili a SINED), **tutti i costi** (accertamento, trasporto, manodopera) saranno addebitati al cliente.

6. ESCLUSIONI E COSTI A CARICO DEL CONSUMATORE

Se il difetto non è coperto dalla garanzia:

- I costi di spedizione/trasporto sono a carico del Consumatore;
- Se il Consumatore desidera comunque effettuare la riparazione, dovrà farsi carico dei costi di ricambi e manodopera.

La garanzia **non è rinnovabile e non prevede risarcimenti** per danni diretti o indiretti derivanti da guasti o difetti del prodotto.

7. DISPOSIZIONI FINALI

La presente garanzia:

- È trasferibile al futuro proprietario del prodotto solo se Consumatore;
- È soggetta alla legge **italiana**.

SUPPLY CONDITIONS

We believe in the quality and durability of our products. For this reason, we offer a 3-year warranty on all SINED brand products.

1. GENERAL INFORMATION

Manufacturer’s Warranty

- “Consumer” means any natural or legal person who owns the product and has not purchased it to resell or install it to third parties in the course of a commercial or professional activity.
- “Initial Customer” or “Reseller” means the first purchaser of SINED brand products, whether a reseller or a professional who resells or installs the product for third parties in the course of their business.

2. WARRANTY PERIOD

The warranty period runs from the date of purchase indicated on the original invoice of the Initial Customer (Reseller).

The warranty lasts for **3 years** from that date, provided that:

- The original invoice is retained and shown upon request;
- The product has been installed and maintained by qualified personnel, according to the instructions and regulations in force.

3. WARRANTY

To activate a warranty service request, the Consumer must:

- Notify the defect in writing to SINED or the Authorized Dealer;
- Present the original invoice demonstrating the date of purchase and the validity of the warranty;
- Ensure that installation and maintenance have been carried out by qualified personnel.

4. WARRANTY LIMITATIONS

The warranty **does not cover**:

- Parts subject to normal wear (cartridges, gaskets, sealing rings, soap pumps, filters, aerators);
- Damage from incorrect installation or the presence of residues in the pipes such as sand or limescale.
- Damage caused by dirt, limescale, improper use, aggressive chemicals, operating errors, impacts, atmospheric agents or extreme environments.

5. WARRANTY VOID

The warranty **lapses** in the following cases:

- Damage caused by force majeure (e.g. fires, floods, frost);
- Improper use or use not in accordance with the instructions for use;
- Installation, maintenance or repairs carried out by unqualified personnel;
- Use of non-original SINED spare parts;
- Deterioration from limescale, electrical surges, atmospheric phenomena;
- Inadequate maintenance or failure to follow the instructions;

Interventions not covered:

- Filter cleaning;
- Cleaning aerators;
- Removing limescale from shower heads, shower heads or surfaces.

In the event of **unfounded complaints** (defects not attributable to SINED), **all costs** (assessment, transport, labour) will be charged to the customer.

6. EXCLUSIONS AND COSTS TO BE PAID BY THE CONSUMER

If the defect is not covered by the warranty:

- Shipping/transport costs are to be paid by the Consumer;
- If the Consumer still wishes to carry out the repair, he will have to pay the costs of spare parts and labour.

The warranty **is not renewable and does not provide compensation** for direct or indirect damages resulting from faults or defects of the product.

7. FINAL PROVISIONS

This warranty:

- Is transferable to the future owner of the product only if a Consumer;
- Is subject to **Italian law**.



Come trovarci?
SINED Ventas Online
S.L



Via Trajana 50-56
Nave 28, Sant Martí,
08020 Barcelona

Polígono industrial de
Montsolís



Italia: Musso Personal Computer Srl
Via Beatrice d'Este 24
20122 Milano, Italia
IT11811400156

España: Sined Ventas Online S.L.
ESB42784397

Oficina, showroom y logística:
Vía Trajana 50-56 Nave 28, Sant Martí,
08020 Barcelona

TELEFONO IT +39 022 1117815
MOBILE IT +39 335 7600875
MOBILE EN/FR +39 3425447140
TELÉFONO ES +34 664 66 64 26
TELÉFONO ES +34 664 66 64 28
CENTRALITA ES +34 935 05 67 23

INFO@SINEDITALIA.COM

SINEDITALIA.COM
SINEDITALIA.IT
SINEDITALIA.ES
SINEDITALIA.FR

CATALOGO-SINED-DESIGN-ACQUA-2026



8 025431 157897

CATALOGO SINED 2026