



EXPERIENCE
THE THRILL OF HEIGHTS



The multi-way splitter is not for sale in the US.

a brand of **WALLTOPIA**

WALLTOPIA

Walltopia is the world leader in climbing walls manufacturing and active entertainment attractions with more than 1800 projects in over 70 countries.

Our Active Entertainment product line evolved from our experience in the climbing wall industry and the natural human craving for play. We were driven by the desire to transform physical activity into amusing and purposeful play, suitable and entertaining for everyone, with no need of specific sport preparation and minimum equipment required for the participants.

Providing versatile experience, in their core our products share one and the same goal. They help us get active and encourage us to spend more time with our family and friends in a meaningful, present way.

That's what we call active entertainment.



EXPERIENCE

THE THRILL OF HEIGHTS

Walltopia Ropes Courses challenge flexibility, balance and strength in a thrill-boosting way, while ensuring maximum safety in conjunction with eurocode safety standards. All our ropes courses offer a wide range of difficulty levels that appeal to both children and adults. The brand's attractions are appropriate for participants as young as five years old.

Key points



MULTI-DEMOGRAPHIC APPEAL

The difficulty of each obstacle can be tailored to preference or to specific age groups.



FLEXIBLE BUSINESS MODELS

Our courses accommodate linear per-ride or multi-directional hourly-ticketed operation models.



OPERATION EFFICIENCY

Highest manufacturing and safety standards ensure hassle-free operation and low maintenance costs.

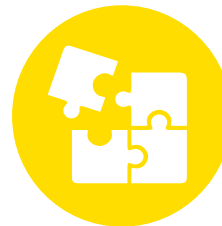

EASY INTEGRATION

Flexible designs & extensive theming options allow for easy integration while strengthening storytelling.



CUSTOMER SUPPORT

Dedicated support from experts during every step of the process brings peace of mind to business owners.



TRUSTWORTHY INVESTMENT

Walltopia has a proven record of more than 60 ropes courses projects successfully led worldwide.

Ideal locations



FECs



**SHOPPING
CENTERS**



OUTDOOR PARKS



**AQUARIUMS &
ZOOS**



**AMUSEMENT &
THEME PARKS**



WATER PARKS



SKI RESORTS



HOTELS

Design, engineering and manufacturing

Each and every ropes course is different – an experienced team of more than 40 designers and engineers create every single project from the ground up given the specific features of the available space. Our manufacturing process complies with all relevant European standards which ensures the highest quality of the final product.



Safety standards

EN 15567	Sports and recreational facilities - Ropes courses	ASCE 7-10	Minimum design loads for buildings and other structures
EN 795	Personal fall protection equipment - Anchor devices	CWA 2009	General specification for the design and engineering of artificial climbing structures
EN 354	Personal fall protection equipment - Lanyards	ASTM F1159	Standard practice for design and manufacture of patron directed, artificial climbing walls, dry slide, coin operated and purposeful water immersion amusement rides and devices and air-supported structures
EN 361	Personal fall protection equipment against falls from a height - Full body harness	ANSI/AISC 360 10	Specification for structural steel buildings
EN 362	Personal protective equipment against falls from a height - Connectors	ANSI/AWC NDS 2015	
EN 12275	Mountaineering equipment - Connectors - Safety requirements and test methods	ETAG 001 Edition 1997	Guideline for ETA of metal anchor for use in concrete
EN 12385	Steel wire ropes - Safety	ETA 05/0133	
EN 1993-1-8	Design of steel structures Part 1-8: Design of joints	EN ISO 9554	Fibre ropes - General specifications
CSN EN 1011-2	Welding - Recommendations for welding of metallic materials Part 2: Arc welding of ferritic steels	ISO 10325	Fibre ropes - High modulus polyethylene 8 strand braided ropes
EN ISO 14341: 2008	Welding consumables - Wire electrodes and weld deposits for gas shielded metal arc welding of non alloy and fine grain steels	ISO 10547	Polyester fibre ropes - Double braid construction
ANSI/ACCT 3-2016	Challenge courses and canopy/zip lines tours standards	TS EN ISO 1968	Fibre ropes and cordage - Vocabulary
2012 International Building Code		TS EN ISO 2307	Fibre ropes - Determination of certain physical and mechanical properties
		EN ISO 1141 Mart 2006	Fibre ropes 3, 4, and 8 strands

Installation

A team of 8 project managers and over 50 full-time Walltopia technicians ensure that the highest quality and safety standards are applied when providing a turn-key solution. All technicians and project managers have passed the Walltopia Academy – trainings for welders, work at height, operation of mobile working platform equipment and others. A civil engineer from the HQ office overviews every installation.



Maintenance

Certified Walltopia technicians are available for routine checks and inspections to make sure the quality of the attraction stays the same throughout the years; even after the warranty period.



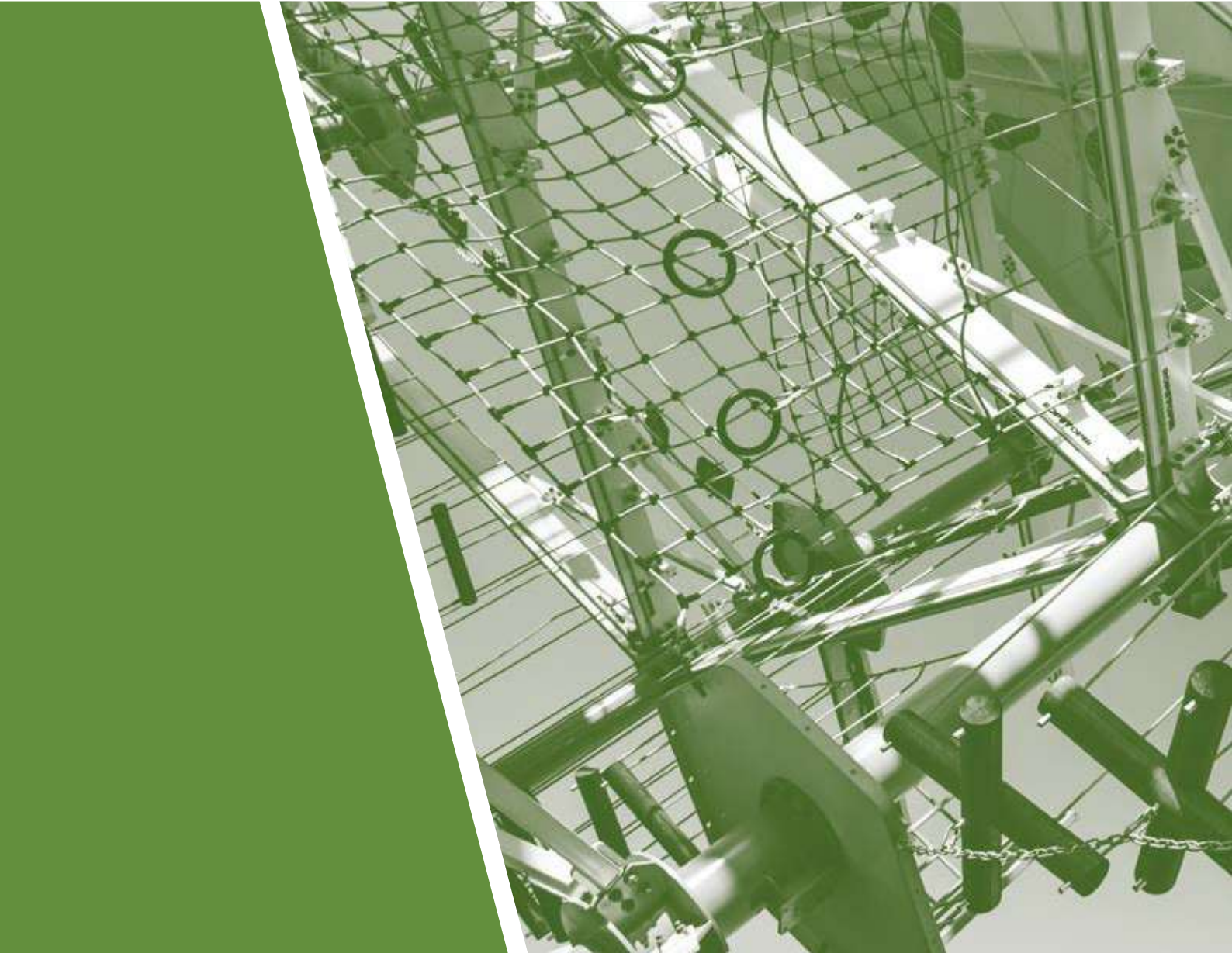

ROPES COURSES **MODELS**

Walltopia Ropes Courses are varied and flexible in order to meet each project's specific requirements and constraints. They can be adapted to accommodate different operation models and floor layouts optimizing throughput.



Hex

Our best-seller the Hex is our bread and butter. Its modularity makes it highly versatile while its design allows for the highest density of obstacles. It is the ideal fit in most situations.

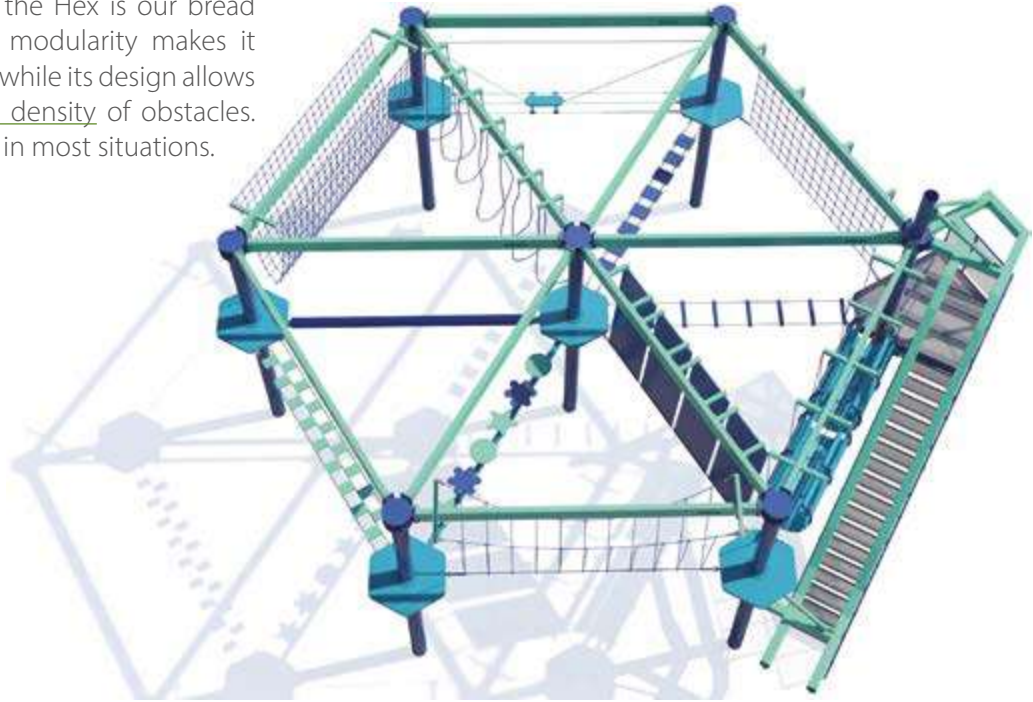

Cube

The go-to solution when there is need for a suspended ropes course because its structure is easy to fix to support beams.



The Tree Course

Standing 26 m (85 ft) tall, sporting a spectacular design and featuring distinctive obstacles, The Tree is designed to be a statement while allowing for a high throughput on a limited footprint.



Hex

- Modular design - easy vertical and horizontal expansion
- Single or multi-level course
- Best multi-directional layout
- Great stand-alone attraction
- Highest guests to footprint ratio
- Theming possibilities

A modular structure

The Hex and Cube structures are composed of individual sections which can be laid out next to each other to expand the course both horizontally and vertically. The angles of the sections form platforms and the sides – obstacles.

The obstacles are available in 4, 5, 6, 7 and 8 m lengths (13.1, 16.4, 19.7, 23 ft)

Key components of the Hex ropes course

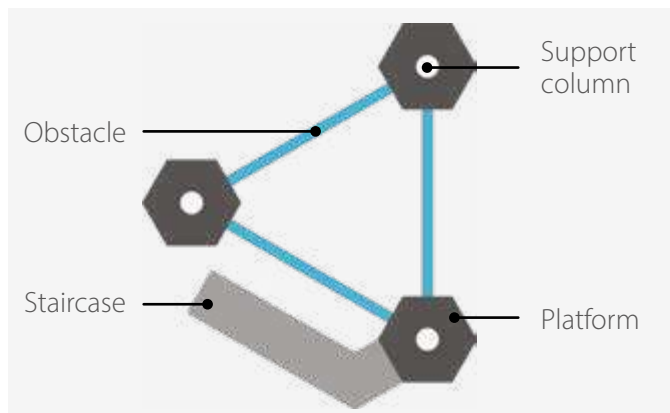

Configuration examples

Slim arrangement
52 obstacles, 4 levels
Footprint: ~ 154 m² / 1658 ft²

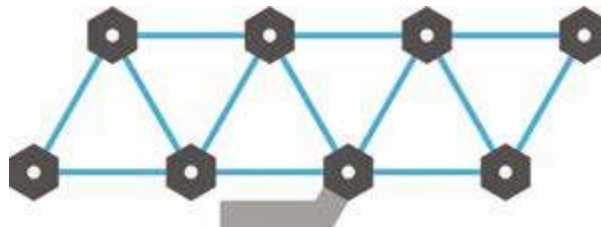



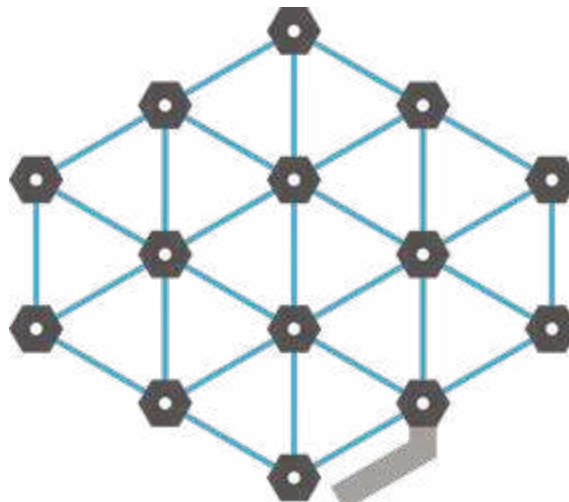

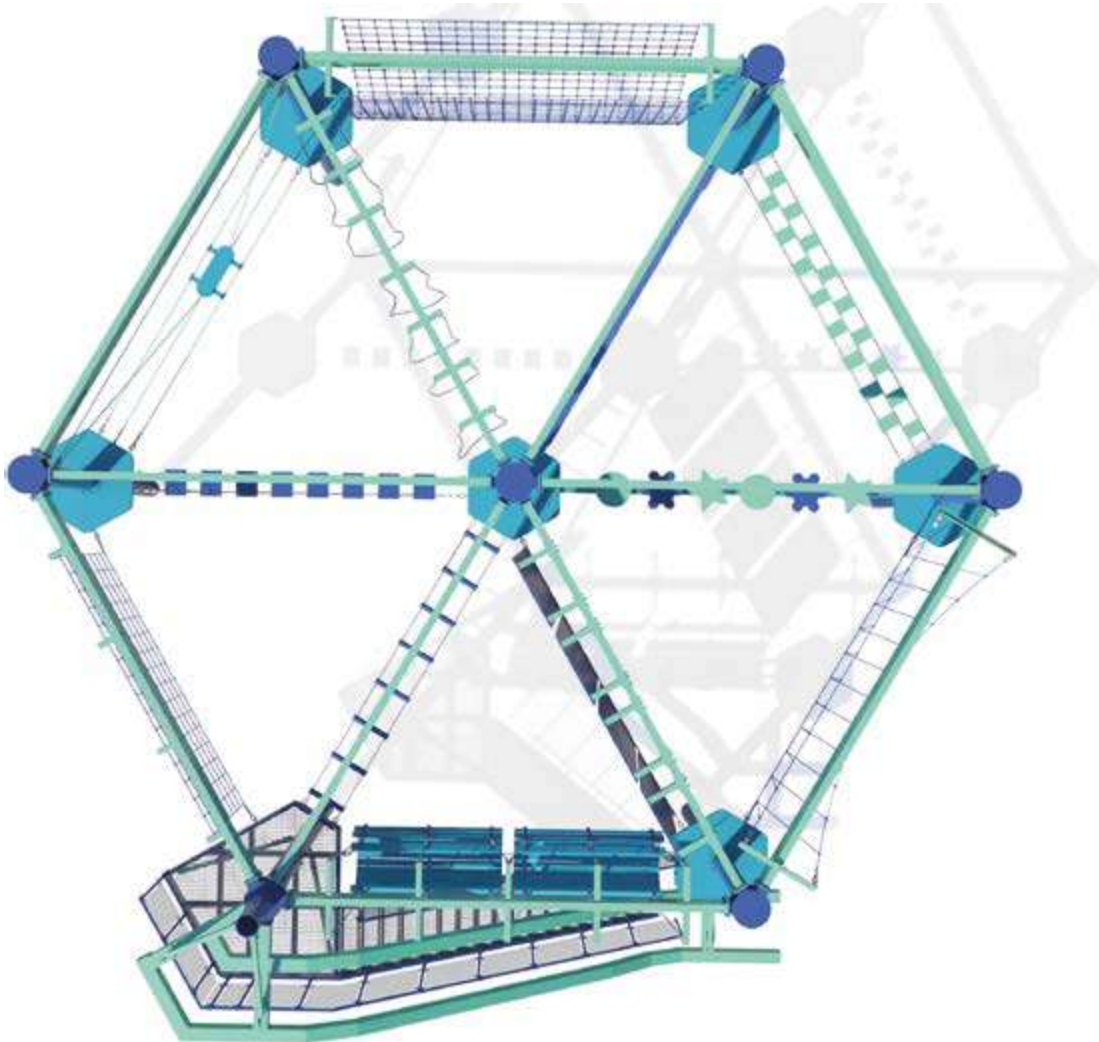
Large arrangement
116 obstacles, 4 levels
Footprint: ~ 418 m² / 4499 ft²



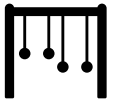

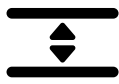
Hex | 7 Poles | 145 m² / 1561 ft²

	 Obstacles	 Optimal capacity	 Average time spent	 Height	 Operators
1 Level	12	19	30 min	3,65 m / 12 ft	1
2 Levels	24	38	1h	7,30 m / 24 ft	
3 Levels	36	57	1h 30	10,95 m / 36 ft	2
4 Levels	48	76	2h	14m / 46 ft	

Cube

- Modular design - easy vertical and horizontal expansion
- Single or multi-level course
- Best linear layout
- Great stand-alone attraction
- High throughput
- Theming possibilities
- Easily suspended from ceiling

Multi-directional layout

This layout leads visitors to spend more time on the course as they try to complete every obstacle.

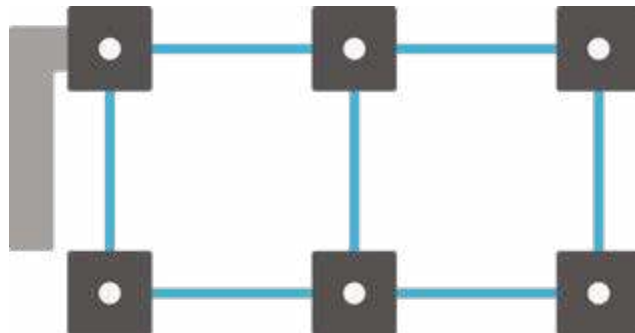

Linear layout

This layout only allows a linear movement through the course resulting in a higher throughput.

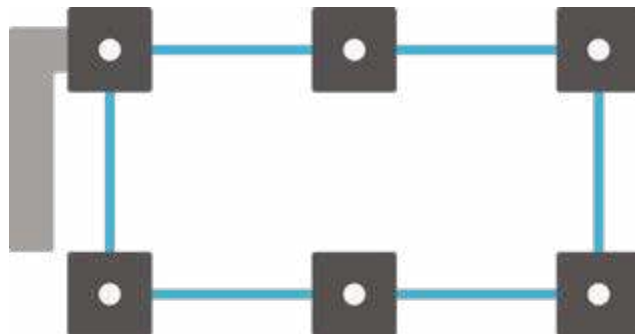



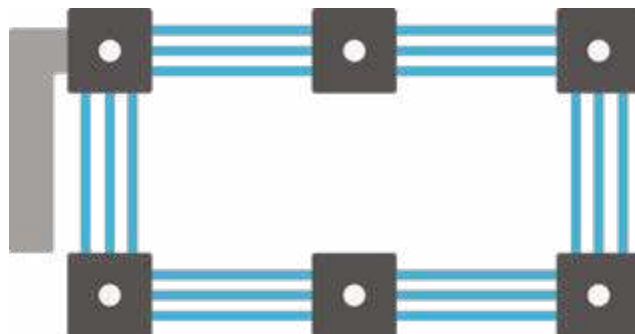

Multi-option linear layout

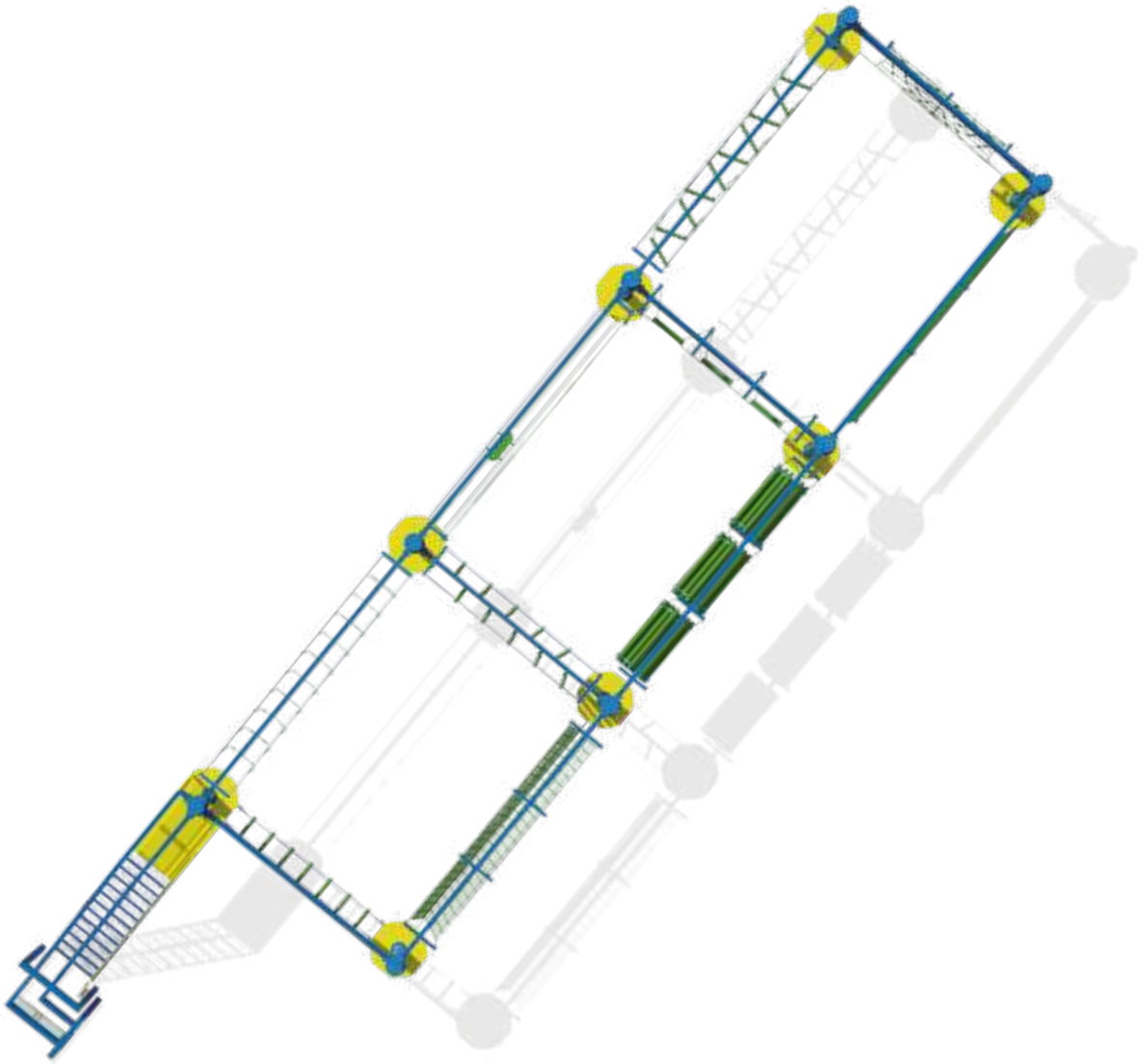
This layout only allows movement in one direction but it offers 3 options at each platform, resulting in a colossal number of ways to complete the course. For example, there are 729 unique ways to complete the course on the right.



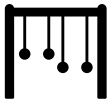

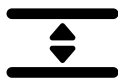
Cube | Suspended 8 Poles | 120 m² / 1292 ft²

	 Obstacles	 Optimal capacity	 Average time spent	 Height	 Operators
Multi-directional	10	18	28 min	3,65 m / 12 ft	1
Linear	8	16	16 min		
Multi-option linear	24				

The Tree

- Unparalleled design
- Single or multi-level course
- Innovative layout
- Star attraction potential
- High throughput on limited footprint
- Theming possibilities
- Integrated viewing deck

A statement





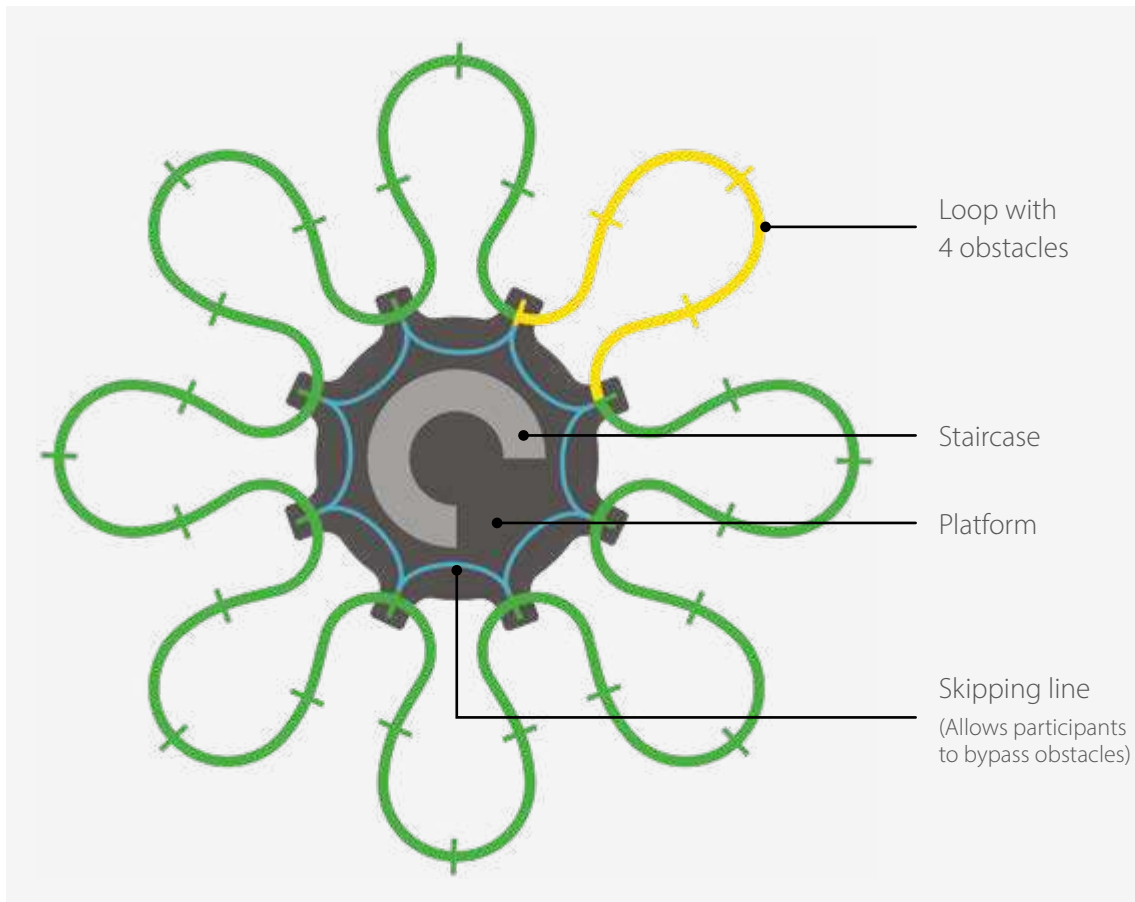

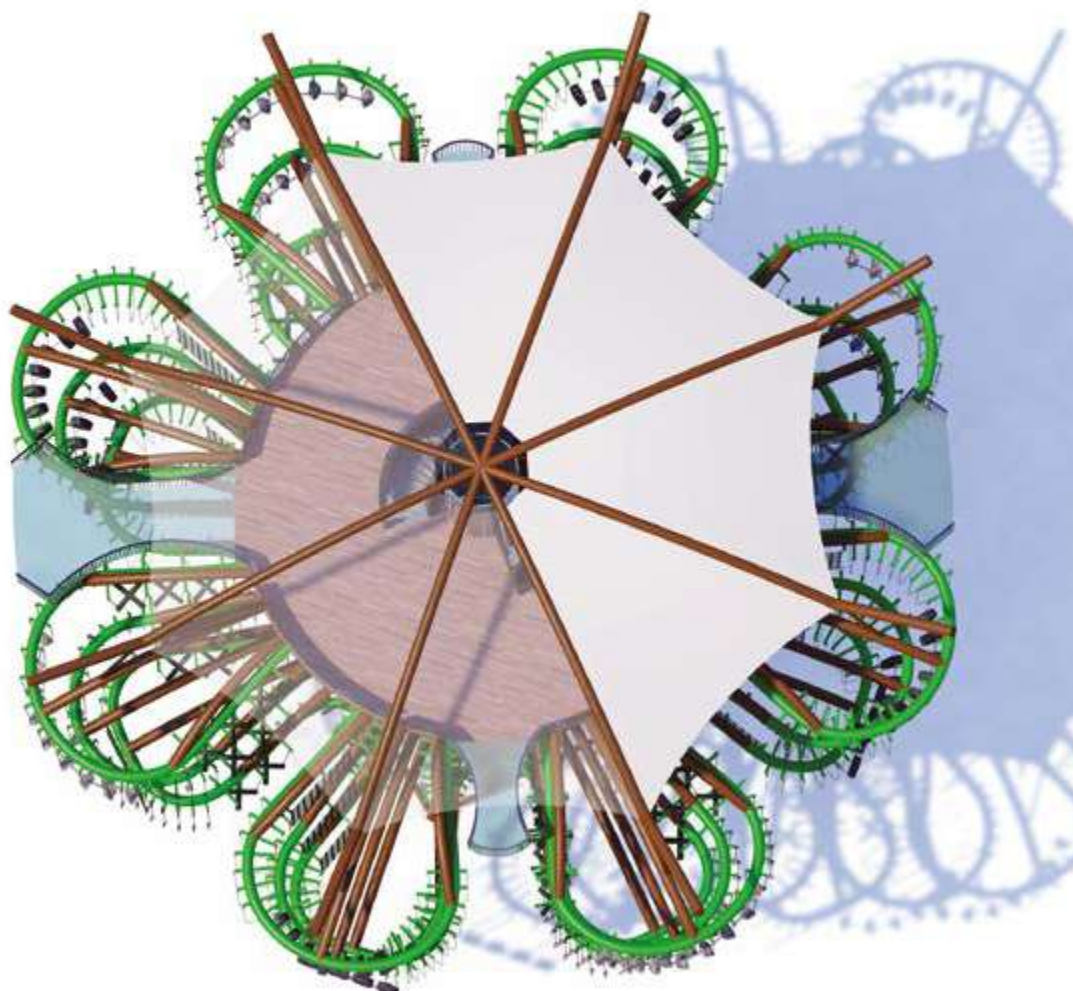
This eye-catching 26 m (85 ft) tall structure, in its 3 levels version, offers 8 loops with 4 consecutive obstacles per level for a total of 96 obstacles. It also features a 135 m² (1453 ft²) viewing deck at the very top which comfortably holds 90 people. The Tree was conceived to be the star of the show and is a massive billboard for any operator lucky enough to own one.

Layout of a level of The Tree

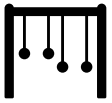

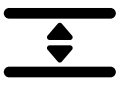

The Tree | 73 m² / 786 ft²

	 Obstacles	 Optimal capacity	 Viewing deck capacity	 Average time spent	 Height	 Operators
1 Level	32	48	N/A	1h	12 m / 39 ft	1-2
2 Levels	64	96	90	2h	18 m / 59 ft	2-4
3 Levels	96	144		3h	26 m / 85 ft	4-6



SAFETY TALK

Walltopia is dedicated to deliver utmost safety for both its clients and their guests. It goes without saying that each ropes course complies with industry standards. However, Walltopia believes that safety is much more than legislation, it's about creating an efficient and inspiring product allowing operators to reduce distractions and truly focus on the quality of what they do. It's about creating better experiences.



Linear Belay Line

Walltopia Ropes Courses come with Walltopia Continuous Belay Line (linear or multi-way*) – a system that allows safe and easy movement through the course. It is highly durable and has low maintenance costs. It is designed, built and tested in accordance to EN 795:2012 standard, type D. It also follows the dynamic test requirements of CEN/TS 16415:213.

Guests movement on a linear belay line

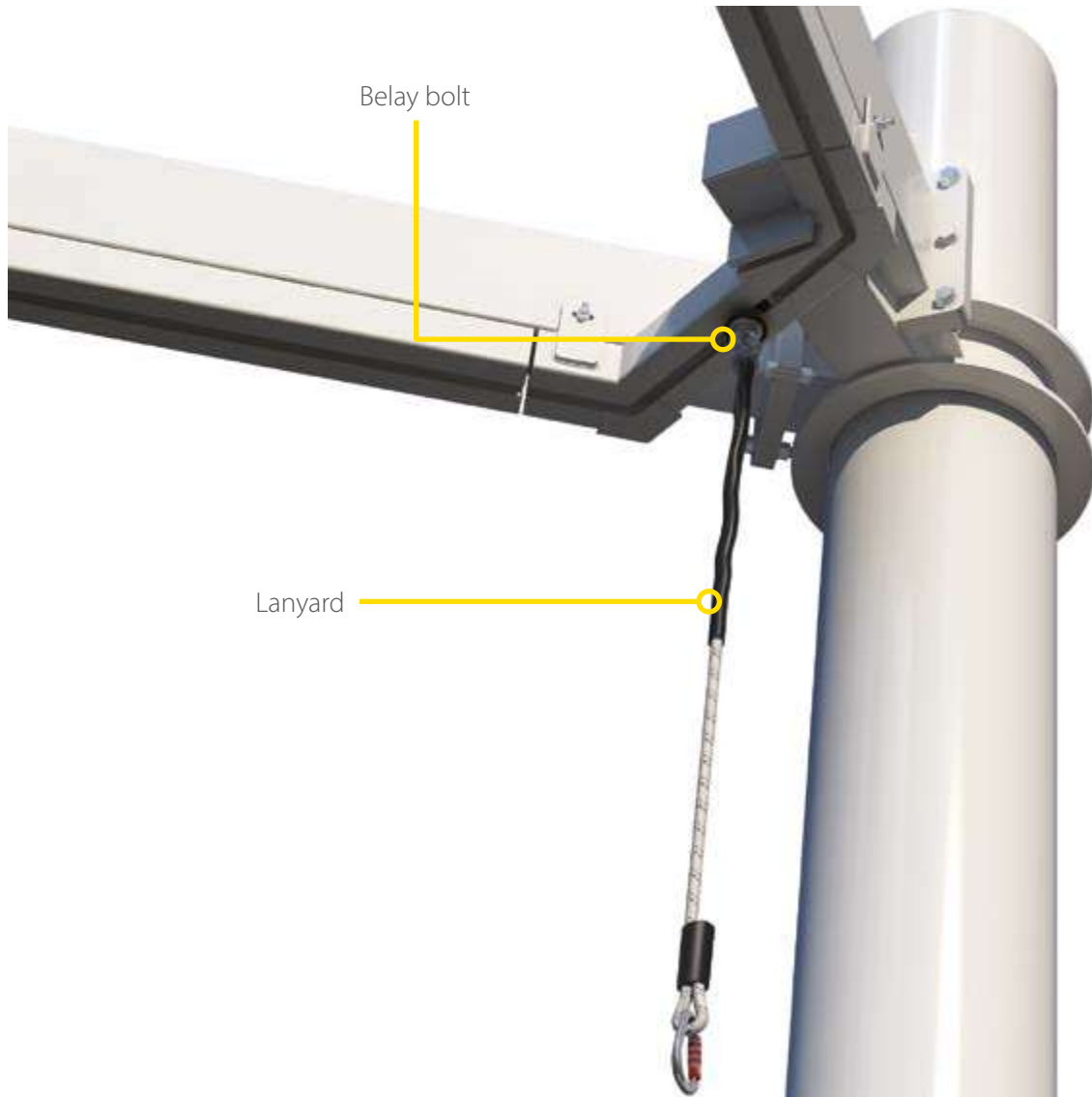
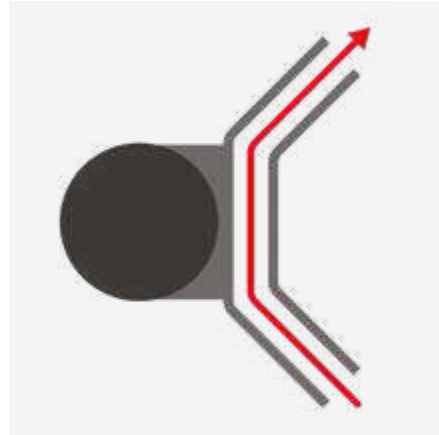

Multi-way Belay Line*

The multi-way continuous belay line is based on a multi-way splitter which allows participants to choose which direction to take at conjunctions. Most importantly, the multi-way splitter allows staff members to quickly jump through different sections to provide assistance to visitors in need.

Guests movement on a multi-way belay line



CLOSE-UP VIEW

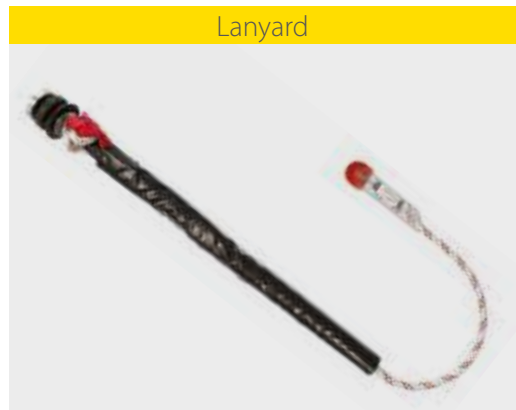

Alternative Belay Systems

Continuous Belay Systems



Niko Rail® is a continuous belay system without any splitters. The system uses a trolley on a rigid line to move through the ropes course but does not offer the option to choose a direction at conjunctions.



Saferoller® is a continuous wire system with integrated trolley which safeguards guests during harnessed activities. As soon as the trolley is attached to the lifeline, it can only be removed at the end of the course by a staff member.

Smart Belay Systems



Smart belay systems use a two-carabiner mechanism installed on a wire belay line where participants need to unclip one of the carabiners at conjunctions and clip to the next obstacle. The system is called “smart” because an automatic mechanism keeps the other carabiner locked while transferring between the obstacles thus avoiding accidental falls.



Walltopia Ropes Courses can be installed with both smart belay systems if required – BORNACK® and Edelrid®.



Times Square, Adventure HQ, Dubai with Evo Bornack continuous belay system

Weather resistance

All our structural elements are duplex-coated to ensure the highest quality standards; free of extra charges. This makes our ropes courses suitable for both indoor and outdoor uses.



Typical pattern of hot-dip galvanized steel

Duplex coating is a double protection method which combines hot-dip galvanization and polyurethane paint to prolongate the service life of structural elements in corrosive environments by up to 60 years.

Ropes

Throughout all our courses we use 6-strand combination ropes with a steel core and PE cover reaching a minimum break load above 4 tons.

Diameter	Construction	Minimum break load
16 mm	6x8x0.70	4500 kg
18 mm	6x8x0.80	5500 kg

Cross-section of the rope

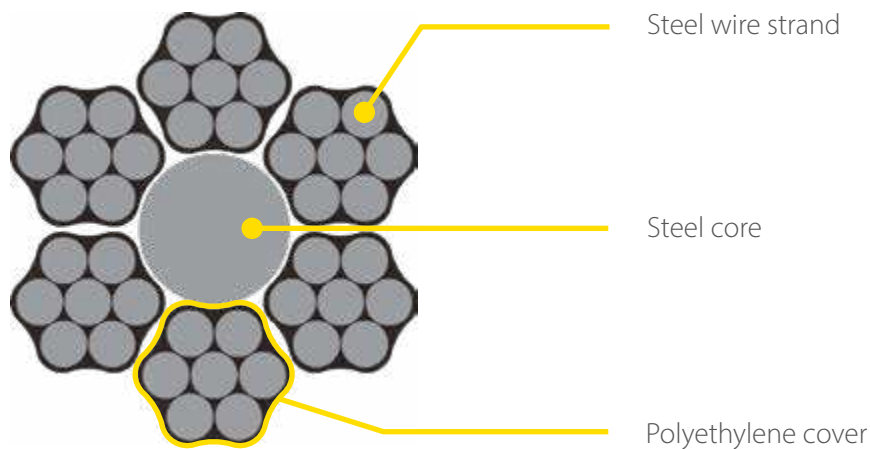



OBSTACLES

With over 100 obstacles, Walltopia has one of the largest catalog of the market. This means that each ropes course delivered is unique and no matter the size, visitors experience a compelling and varied array of obstacles.



Obstacle categories

The obstacles are divided into four categories based on the experience offered: bridges, platforms, traverses and specials.

Bridges consist in horizontally connected elements and usually allow the participant to step on the rope which connects the floor elements. They tend to offer more width than the other types and are generally easier.

Platforms are made of individual elements. Participants must step on these to complete the obstacle. The size of the elements and the distance between them govern how hard these are. Both hands and feet are usually involved.

Traverses rely on vertically aligned elements which offer little to no width resulting in participants having to adopt a sideways motion to complete them. Alike platforms, traverses typically involve both feet and hands as well.

Specials, as the name suggests, refer to unique obstacles usually providing a mix of different experiences.

If you couldn't find your heart's desire among our collection or have something specific in mind, we offer the option to develop bespoke obstacles. Get in touch with us to start designing the ropes course of your dreams.

Obstacle size

The obstacles are available in standard sizes from 4, 5, 6, 7 and 8 meters long (13.1 to 23 ft) while the height is set at 2,20 meters (7.2 ft).

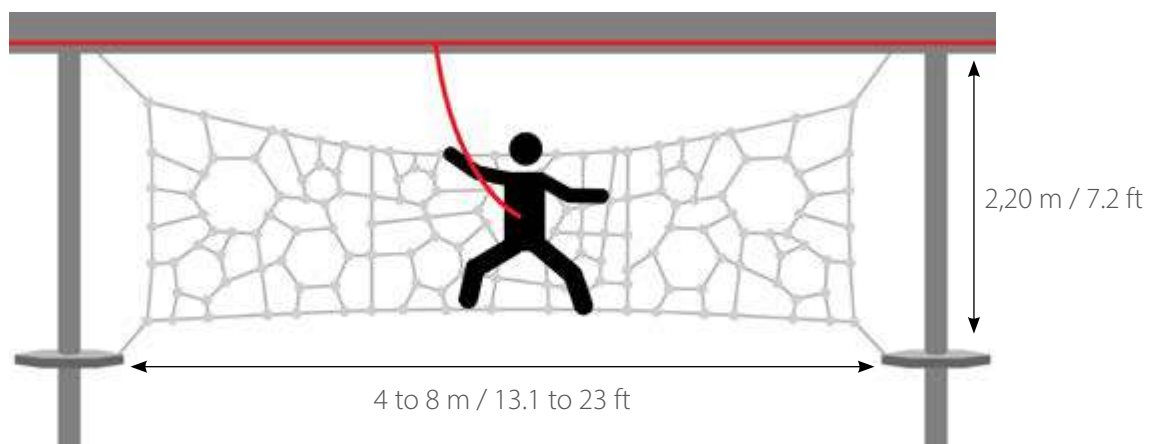

Bridges

MEDIUM
Balance Beam



EASY
Barrels

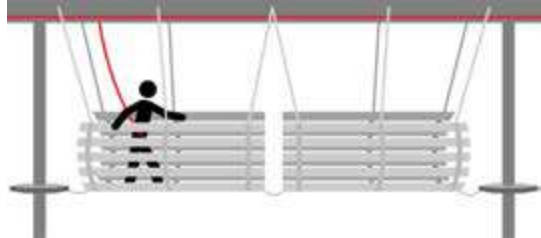

MEDIUM
Battering Ram

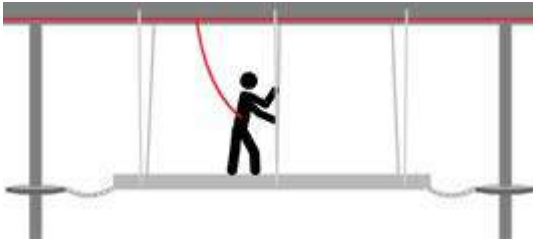

MEDIUM
Broken Bridge

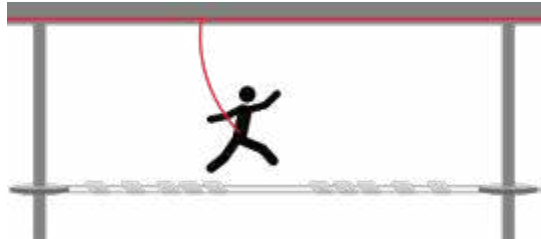

EASY
Burma Bridge



HARD
DNA Bridge

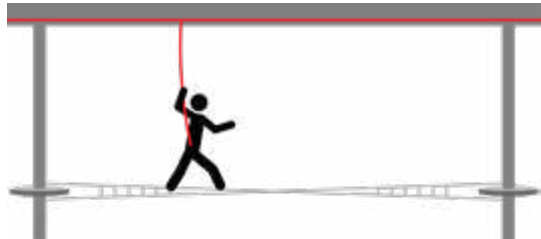

EASY
Double Net

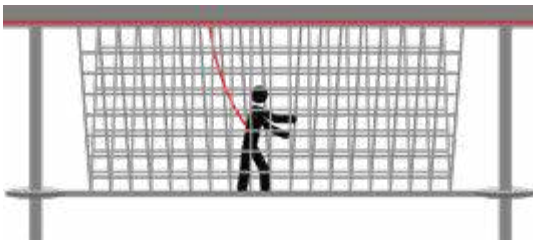

HARD
Driftwood Bridge

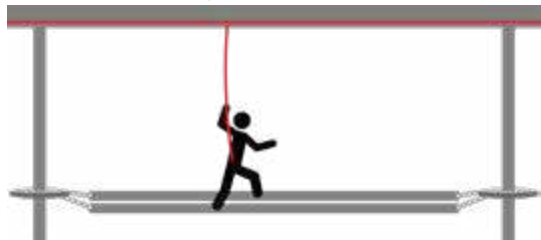

MEDIUM
Dropping Bridge

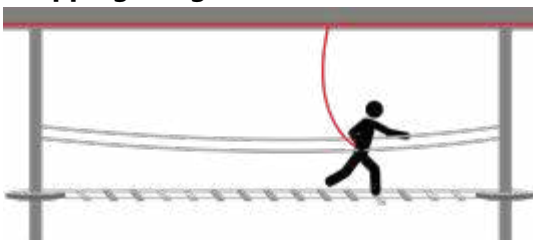

HARD
Hand Bridge

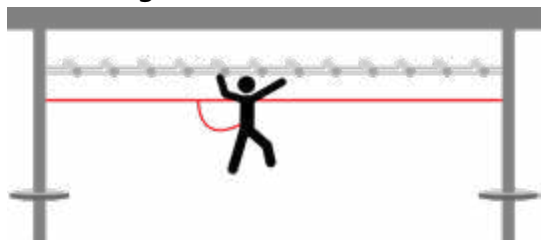

Bridges

HARD
Hand Loops & Rope



EASY
Happy Hopper



MEDIUM
Indiana Bridge

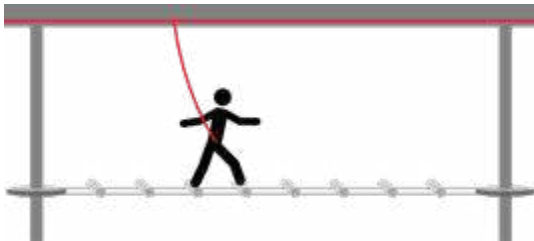

EASY
Lighting Triangles

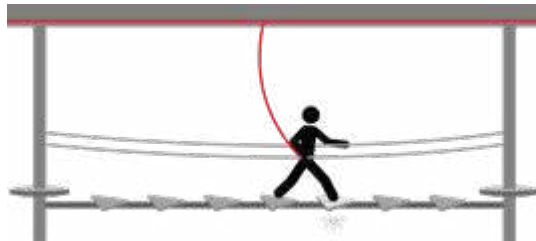

EASY
Narrow Planks

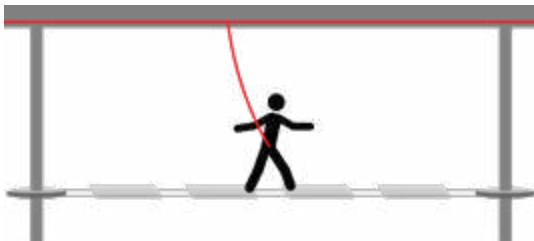

MEDIUM
Net & Planks

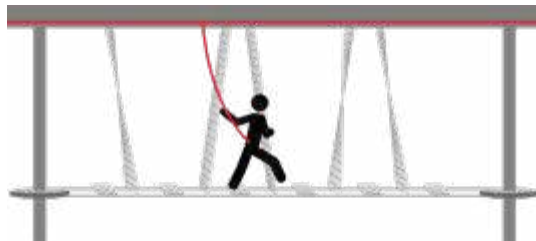

MEDIUM
Planks Bridge

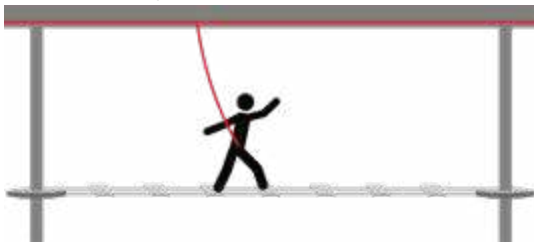

EASY
Plexiglass Traverse

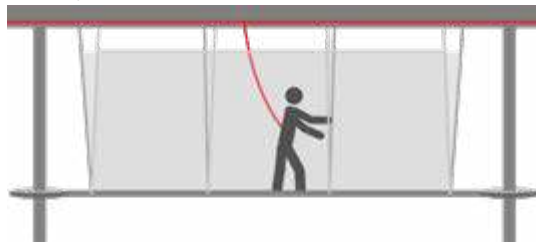

HARD
Postman Walk 1

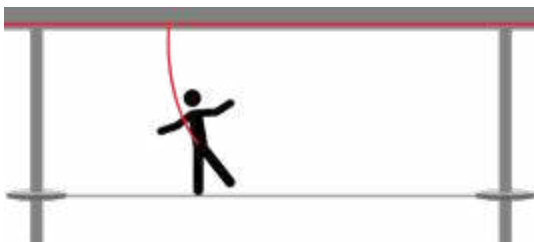

HARD
Postman Walk 2

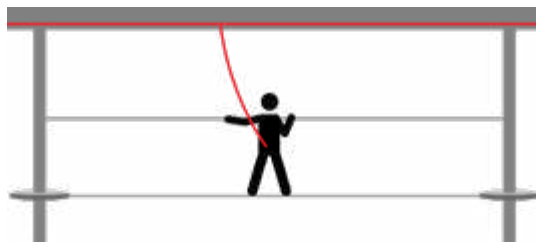

Bridges

MEDIUM
Rocks & Platforms

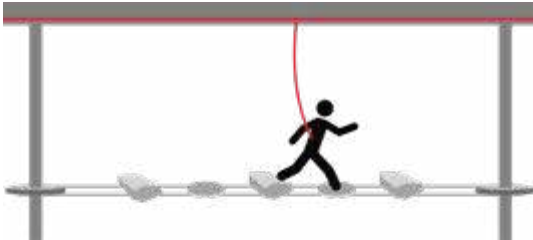

MEDIUM
Rocks Bridge



MEDIUM
Rollers Bridge

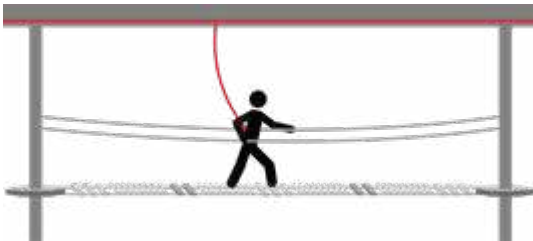

HARD
Rollers Bridge Advanced



MEDIUM
Rope Trail

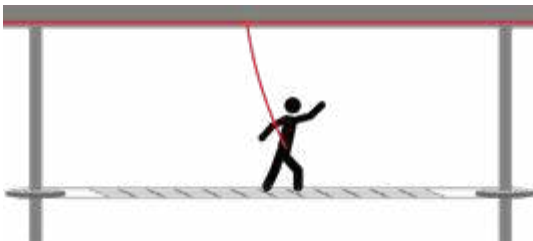

HARD
Ropes

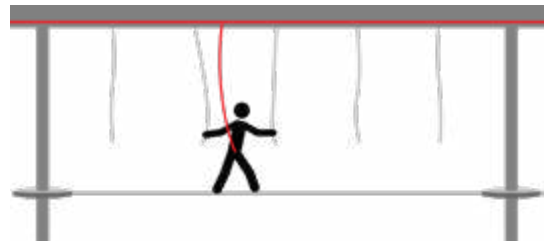

MEDIUM
Rotating Planks



EASY
Sloped Stairs



MEDIUM
Tires Alley



MEDIUM
Tunnel Net

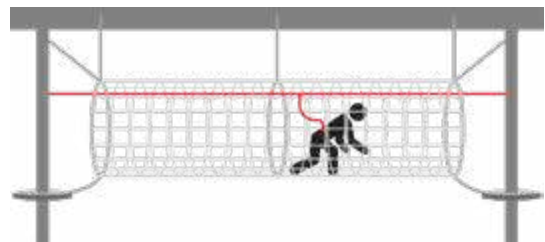

Bridges

HARD
Two Ropes Bridge

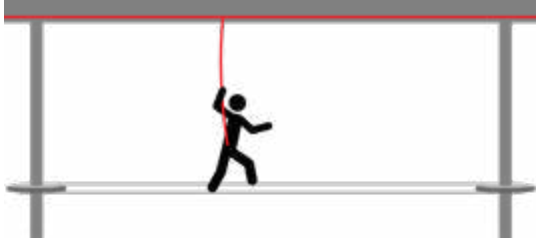

MEDIUM
Two-level Bridge



MEDIUM
Up & Down Beam

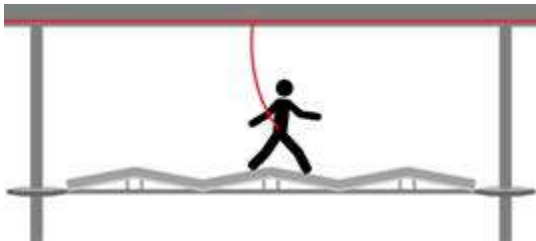

EASY
Wave Bridge

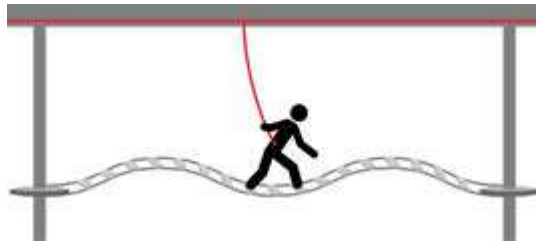

MEDIUM
Wave Bridge & Balls

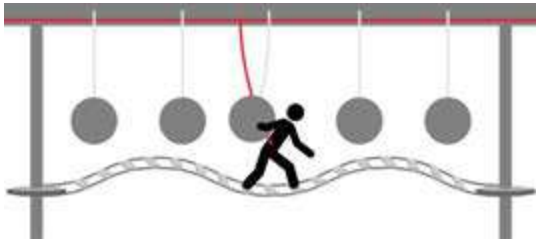

HARD
Web Bridge

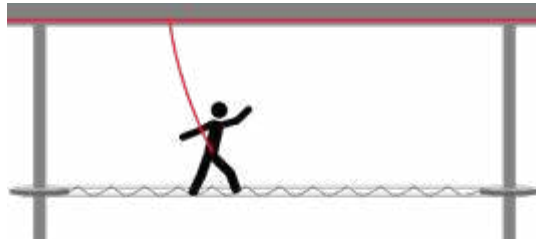

HARD
X-Bridge

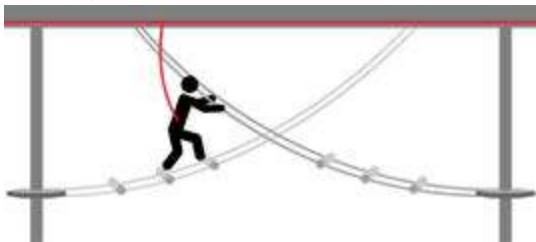

MEDIUM
X-Sticks

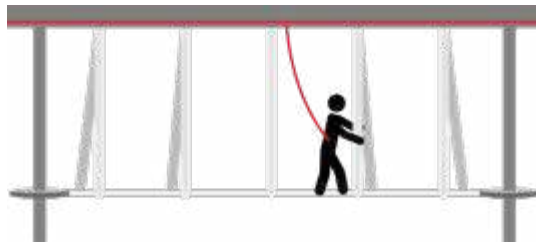

EASY
Zig Zag Bridge 1

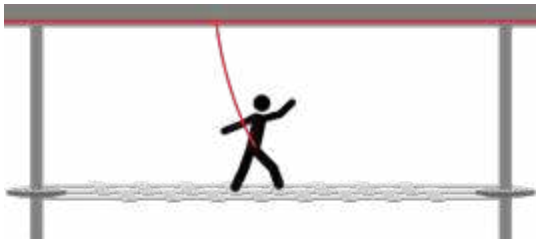

EASY
Zig Zag Bridge 2

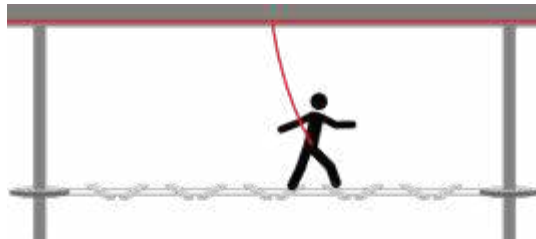

Platforms

MEDIUM
Bolts & Nuts



EASY
Bosu Bridge



MEDIUM
Bosun's Chairs

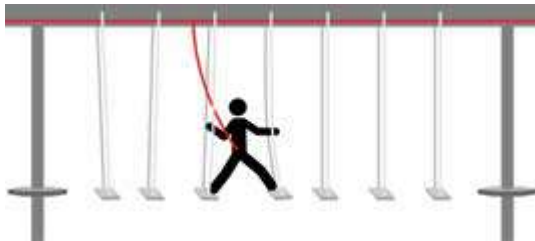

HARD
Bosun's Loops



MEDIUM
Buckets

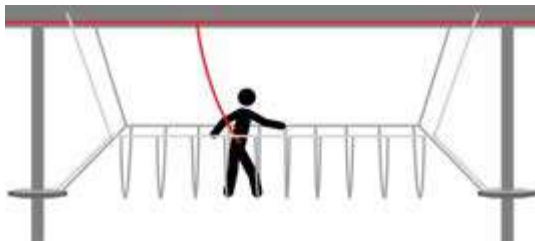

MEDIUM
Criss-cross Logs



HARD
Crossed Loops



HARD
Deep Buckets

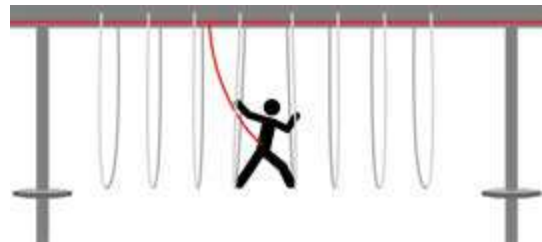

MEDIUM
Flying Tires



MEDIUM
Geometry Islands



Platforms

HARD
Hands Loops



MEDIUM
Hanging Rocks



MEDIUM
Mixed Logs



MEDIUM
Moving Pistons

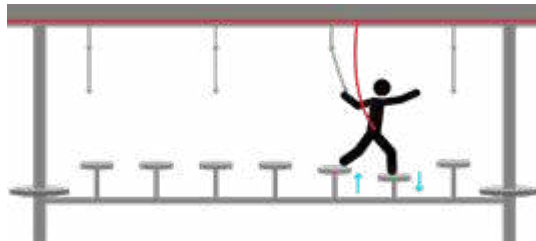

MEDIUM
Multi Log Burma



HARD
Passage Of Fear

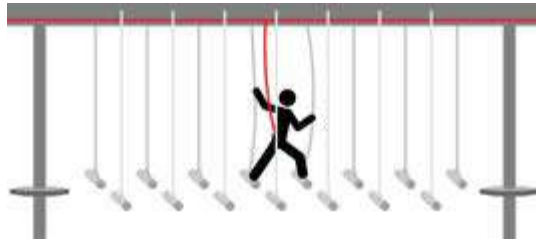

HARD
Pyramid Nets



MEDIUM
Ropes Logs



EASY
Roundabouts

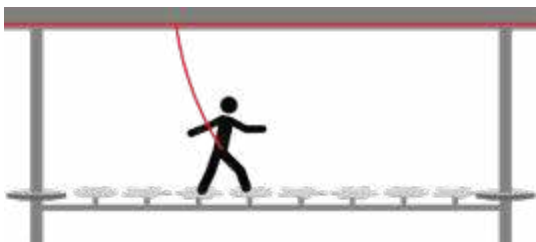

EASY
Static Pistons

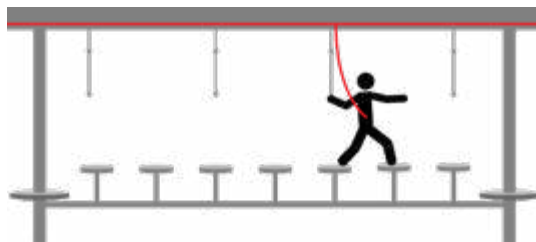

Platforms

EASY
Steps



MEDIUM
Swinging Logs



MEDIUM
Swings



MEDIUM
Tires



EASY
Toxic Jump



HARD
Twisted Ropes



HARD
Vertical Pipes

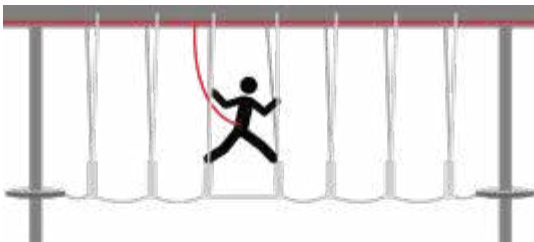

MEDIUM
Zig Zag Alley

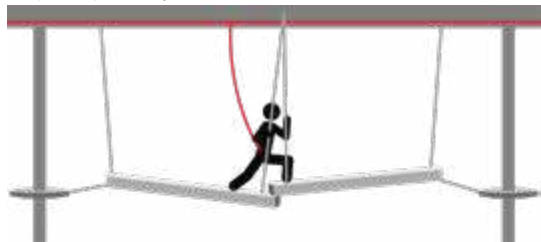

MEDIUM
Zig Zag Swings



Traverses

MEDIUM
Chaos Logs

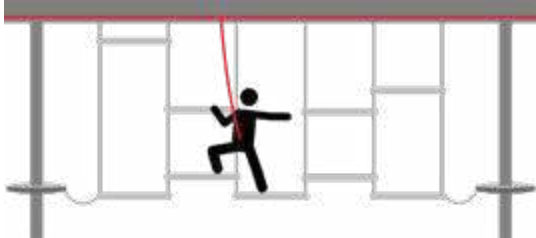

MEDIUM
Climber



EASY
Commando Passage

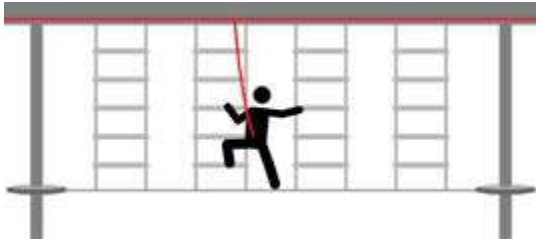

MEDIUM
Gears

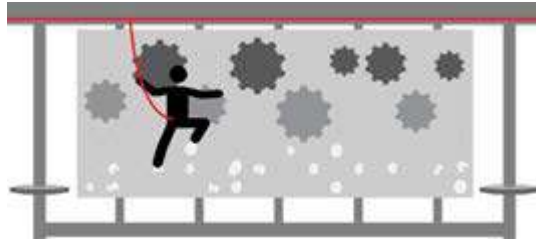

HARD
Logs & Holds



EASY
Molecules Net

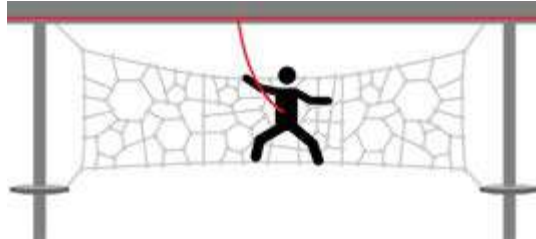

EASY
Net

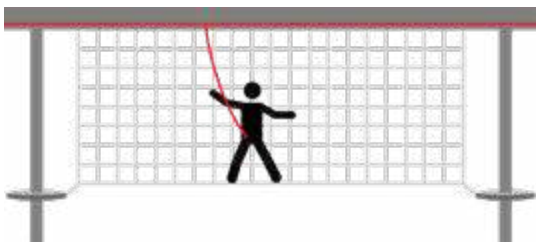

MEDIUM
Net to Net

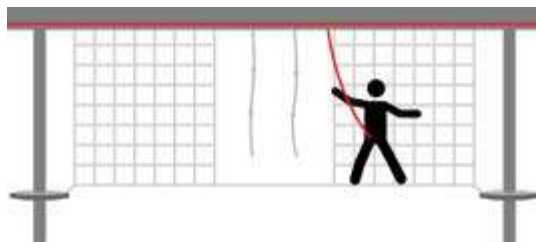

EASY
Spider Web

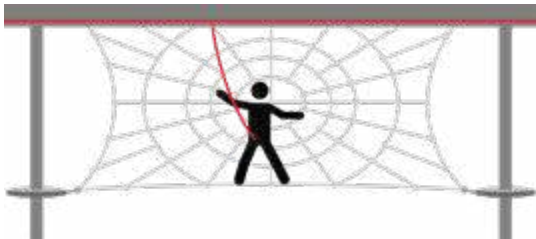

MEDIUM
Sticks Bridge



Traverses

MEDIUM
Swapped Net

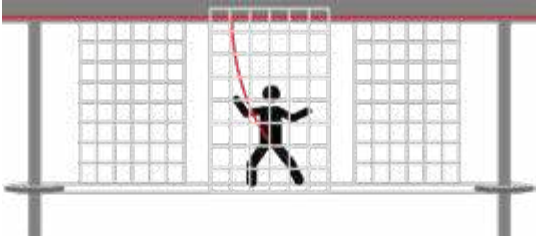

HARD
Swaying Logs



HARD
Twisted Net



MEDIUM
V-Net

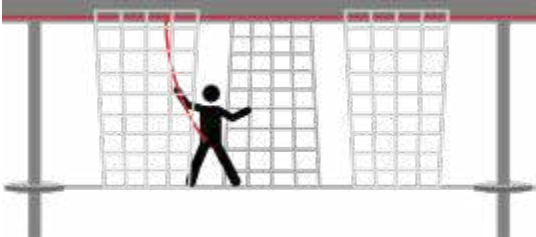

MEDIUM
Windows



Specials

MEDIUM
Double Punching Bags

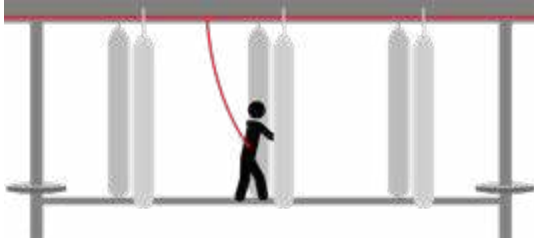

MEDIUM
Hanging Macaronis (Net)



MEDIUM
Hanging Macaronis (Ropes)



EASY
Photo Bench



EASY
Punching Bags

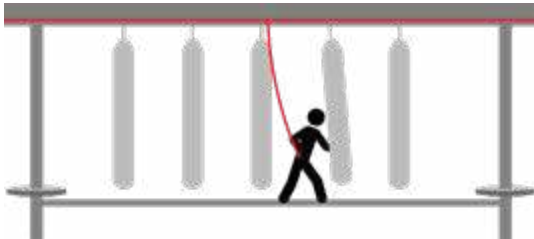

MEDIUM
Rollers

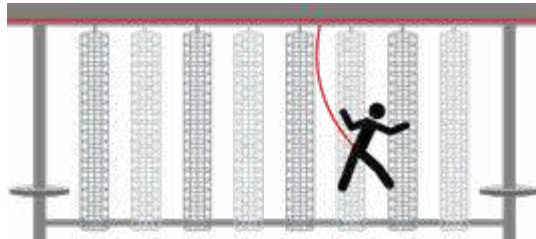

MEDIUM
Silhouettes



MEDIUM
Skateboards

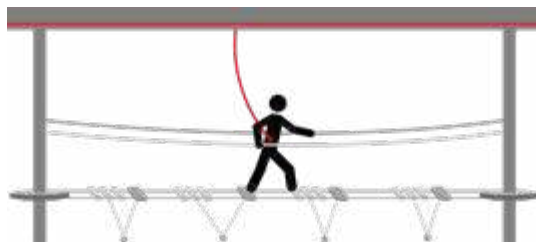

MEDIUM
Snowboard

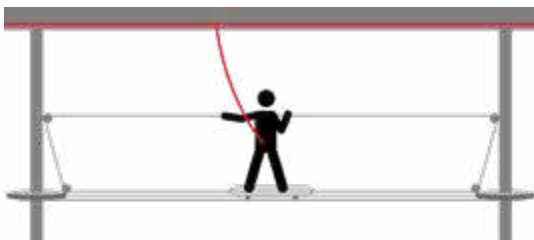

EASY
Spider Box 1

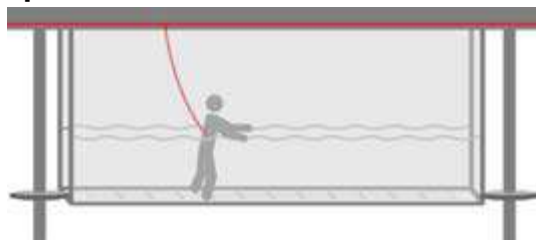

Specials

MEDIUM
Spider Box 2



HARD
Spider Box 3

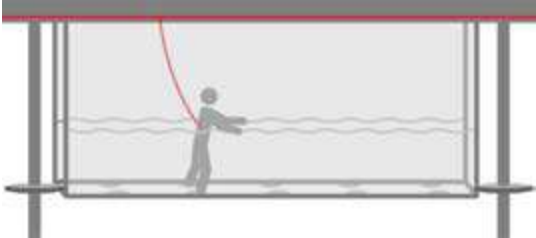

MEDIUM
Swing

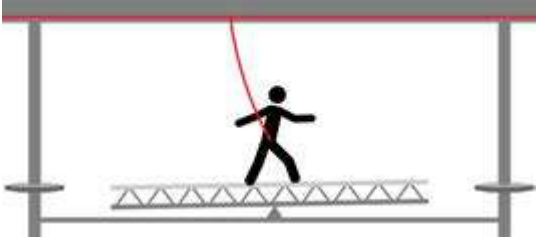

HARD
The Piano



HARD
The X

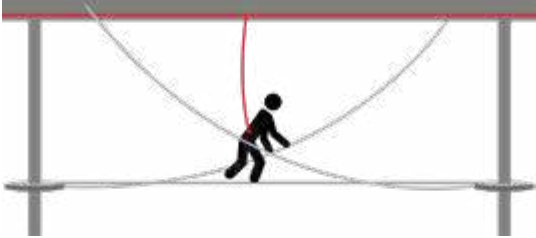

MEDIUM
Walk The Plank



HARD
X-Double Rope

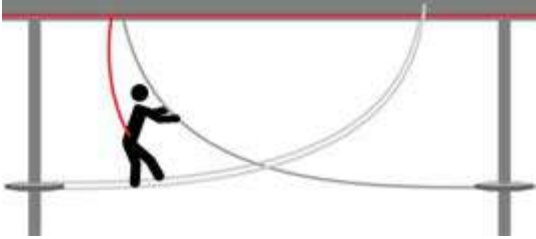



COLORS & THEMING

The visual landscape of each course is discussed from the beginning of the design process to ensure a visually striking display through appropriate theming and use of colors thus building up customers' expectations and ultimately improving their experience.



Colors

Walltopia Ropes Courses come in seven standard color combinations which run through the ropes, obstacles, beams, columns, splitters, platforms and other structural elements.

These combination have been carefully created in order to cover as many usage scenarios as possible. Naturally custom colors stay available upon request as an extra-cost option.

Standard color combination

Marine

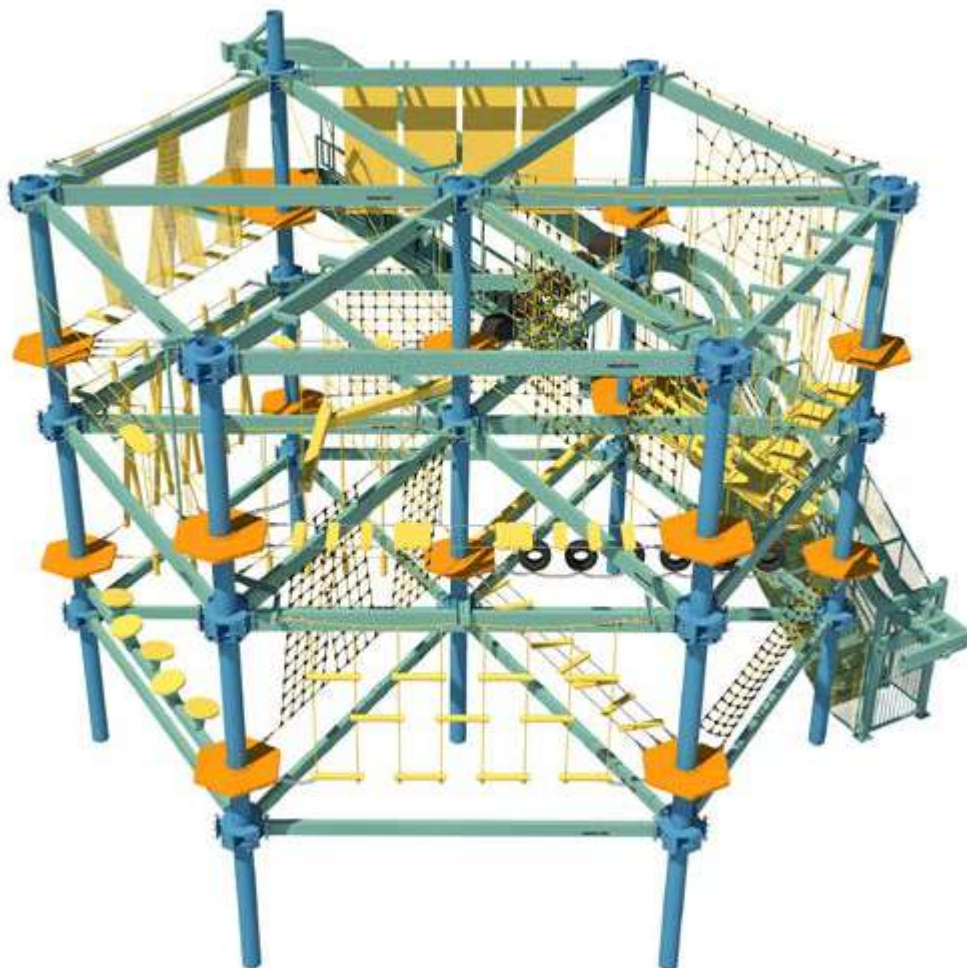

Ropes

RAL 1020

Obstacles

RAL 1018

Beams

RAL 6027

Columns & Splitters

RAL 5015

Platforms & Stairs

RAL 1033

Standard color combination
Spring

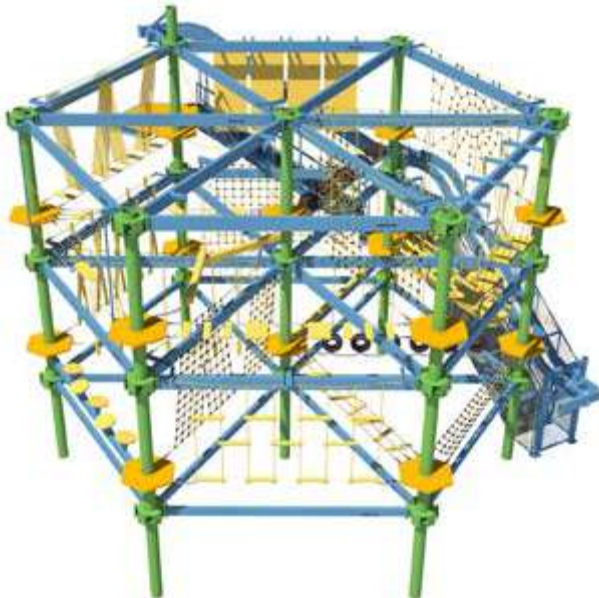

Ropes

RAL 1020

Obstacles

RAL 1018

Beams

RAL 5012

Columns & Splitters

RAL 6018

Platforms & Stairs

RAL 1023

Standard color combination
Summer

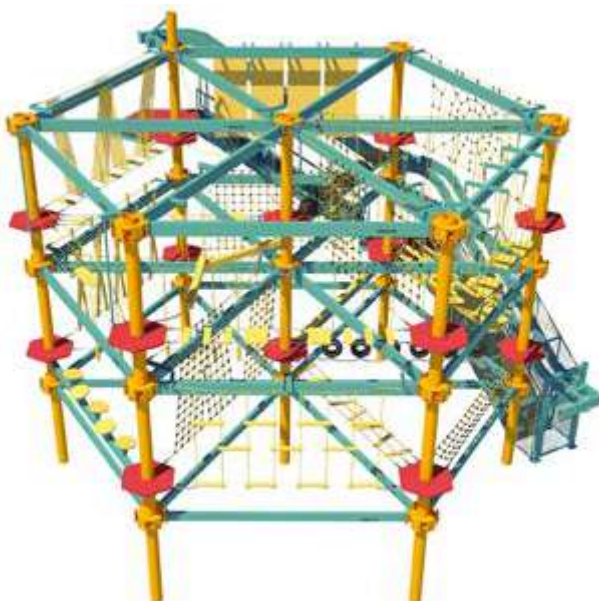

Ropes

RAL 1018

Obstacles

RAL 1018

Beams

RAL 5018

Columns & Splitters

RAL 1023

Platforms & Stairs

RAL 3018

Standard color combination
Industrial



Ropes

RAL 9005

Obstacles

RAL 1018

Beams

RAL 7035

Columns & Splitters

RAL 7009

Platforms & Stairs

RAL 1018

Standard color combination
Forest



Ropes

RAL 1020

Obstacles

RAL 8003

Beams

RAL 6018

Columns & Splitters

RAL 8003

Platforms & Stairs

RAL 6029

Standard color combination
Candy



Ropes

RAL 1018

Obstacles

RAL 1018

Beams

RAL 4010

Columns & Splitters

RAL 1018

Platforms & Stairs

RAL 5018

Standard color combination
Sunset

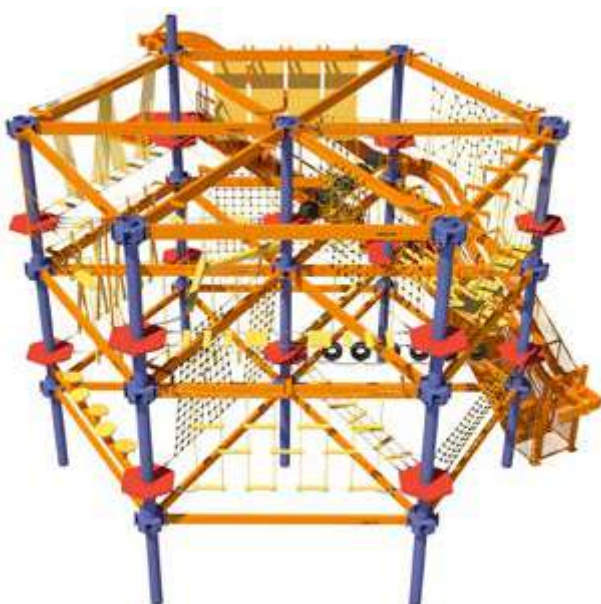

Ropes

RAL 1020

Obstacles

RAL 1018

Beams

RAL 1037

Columns & Splitters

Design RAL 290 50 40

Platforms & Stairs

RAL 3020

Theming

A step further than color palettes, our theming options are ideal to strengthen storytelling and create a more immersive experience.

Space theme

Galaxy Park | Ukraine



Jungle theme
Oxígeno Human Playground | Costa Rica





ADD-ONS

Take Walltopia Ropes Courses to the next level by adding extra layers of fun and comfort for the visitors. These add-ons on top of improving the experience and creating customer loyalty, can generate substantial additional revenue streams.



Gamification



Our gamification option introduces elements such as rankings, bonuses, achievement tracking, quests, team competitions, treasure hunts & capture the flag games to further guests' engagement. This feature is a billboard for operators and is usually reflected in the price of the ticket.

On-ride camera

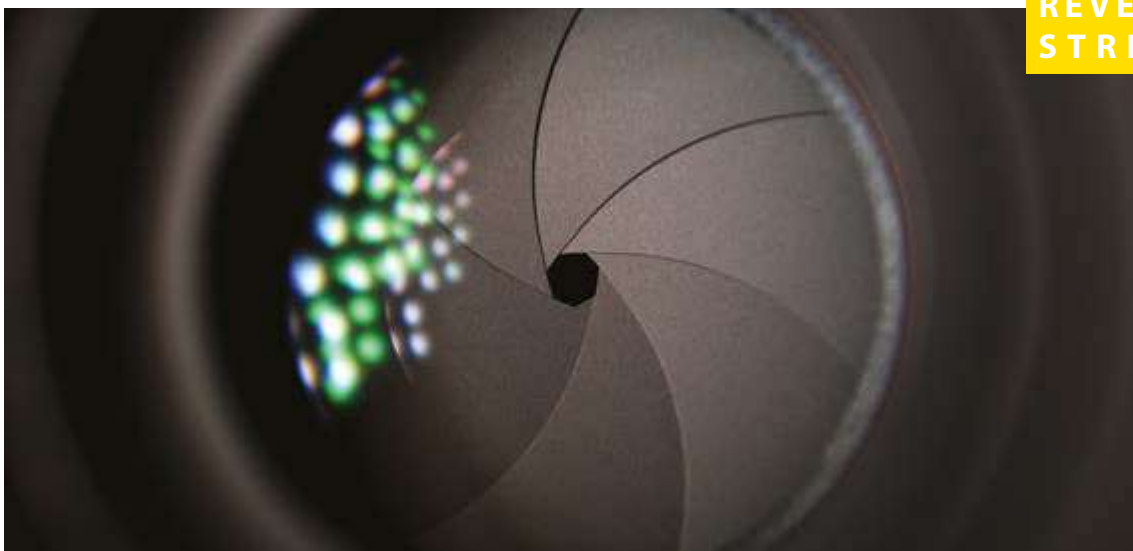

The camera can be mounted on a platform to be manually used or configured to automatically photograph the visitors mid-obstacle, capturing humorous expressions due to fear and excitement. The pictures are then available for viewing and purchase as a souvenir.

Free-fall device



REVENUE
STREAM



The QUICKjump Free Fall device gives jumpers a thrilling free fall experience before softly catching them and lowering them onto the ground. It offers a secondary exit from the course; we recommend charging it as an extra on top of the price of the ticket.

Zip line



REVENUE
STREAM



The zip line option, similarly to the free-fall device, offers a secondary exit from the course to the visitors. This last rush of adrenaline acts as a “grand finale” and leaves a long-lasting impression on the visitors’ mind. We recommend charging it as an extra on top of the price of the ticket.

Sound system



The sound system option engages visitors' auditory sense thus heightening the immersiveness of the experience. It achieves particularly well with themed courses, for example playing wild animals noises in a jungle theme.

Lights



Adding lights to a ropes course is a simple but very effective way to extend operating hours consequently increasing generated revenues.

Tents



Offering an effective protection from the sun, tents allow outdoor ropes courses to retain their attractiveness during the hottest moments of the day. A simple strategy to secure cash flow.

Viewing platform

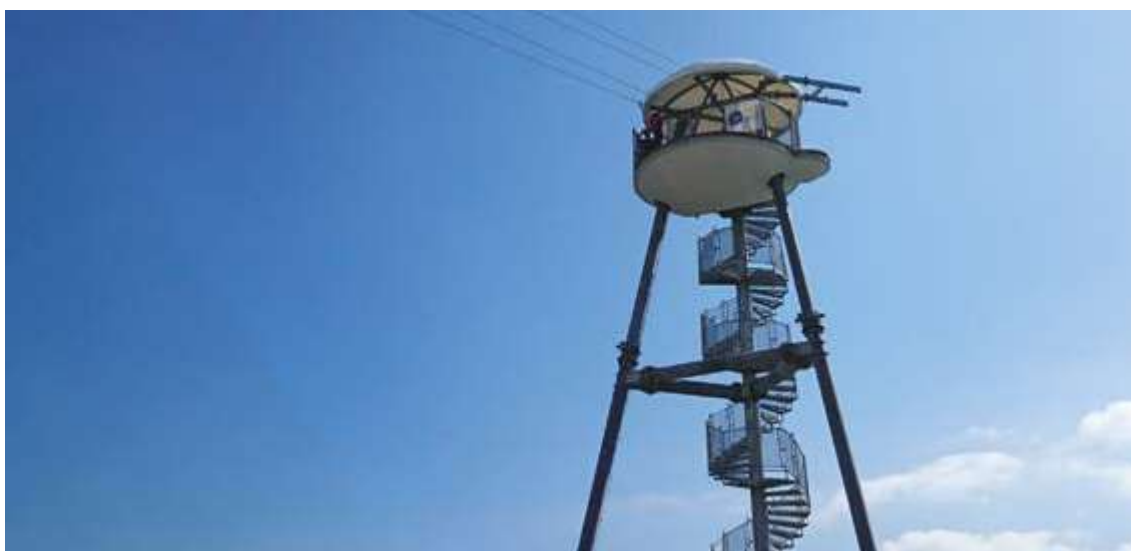

The viewing platform, also available on a stand-alone basis, synergizes well with ropes courses by offering a resting and waiting zone for the participants' friends and family.



COMPLETED PROJECTS

A selection of projects showcasing the ropes courses' flexible nature and Walltopia's experience delivering first-rate solutions to clients world-wide; because pictures speak louder than words.

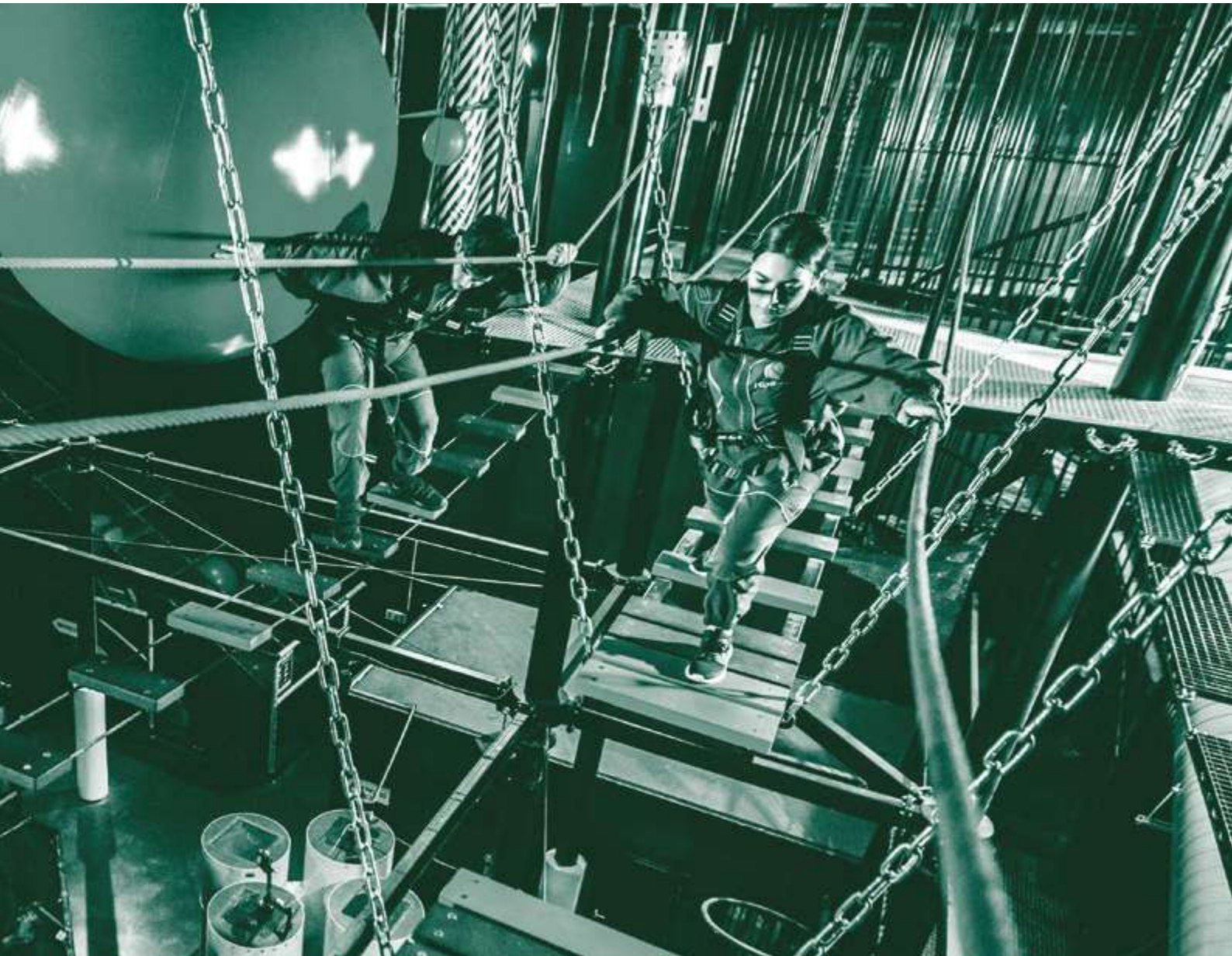

Great Wolf Lodge

Gurnee, IL, USA | Indoor water park resort



Model: Hex, self-standing
Layout: Linear
Operation model: Single climb or day pass
Features: Theme, Climbing walls

Size: 70 m² / 753 ft²
Optimal capacity: 25 ppl
Levels: 3
Obstacles: 13



Great Wolf Lodge

Atlanta, GA, USA | Indoor water park resort



Model: Hex, self-standing
Layout: Linear
Operation model: Single climb or day pass
Features: Theme, Climbing walls

Size: 160 m² / 1722 ft²
Optimal capacity: 46 ppl
Levels: 2
Obstacles: 28



Big Bird

Le Bugue, France | Amusement park



Model: Hex, self-standing
Layout: Multi-directional
Operation model: Day pass
Feature: Tents

Size: 350 m² / 3770 ft²
Optimal capacity: 114 ppl
Levels: 4
Obstacles: 74



Hoplop

Helsinki, Finland | Family entertainment center



Model: Cube, suspended
Layout: Multi-directional
Operation model: Day pass
Features: Rollglider, Climbing walls

Size: 220 m² / 2400 ft²
Optimal capacity: 37 ppl
Level: 1
Obstacles: 21



Koezio

Brussels, Belgium | Adventure park



Model: Cube, self-standing
Layout: Linear
Operation model: Per sessions
Features: Photo bench, custom obstacles

Size: 1,080 m² / 11,650 ft²
Optimal capacity: 90 ppl
Level: 1
Obstacles: 32



Panda Park

Moscow, Russia | Shopping center



Model: Hex, self-standing
Layout: Multi-directional
Operation model: Per sessions
Features: Climbing walls, Rollglider, Fun Walls

Size: 830 m² / 8940 ft²
Optimal capacity: 52 ppl
Level: 1
Obstacles: 24



Adrenaline Monkey

Cleveland, OH, USA | Indoor adventure park

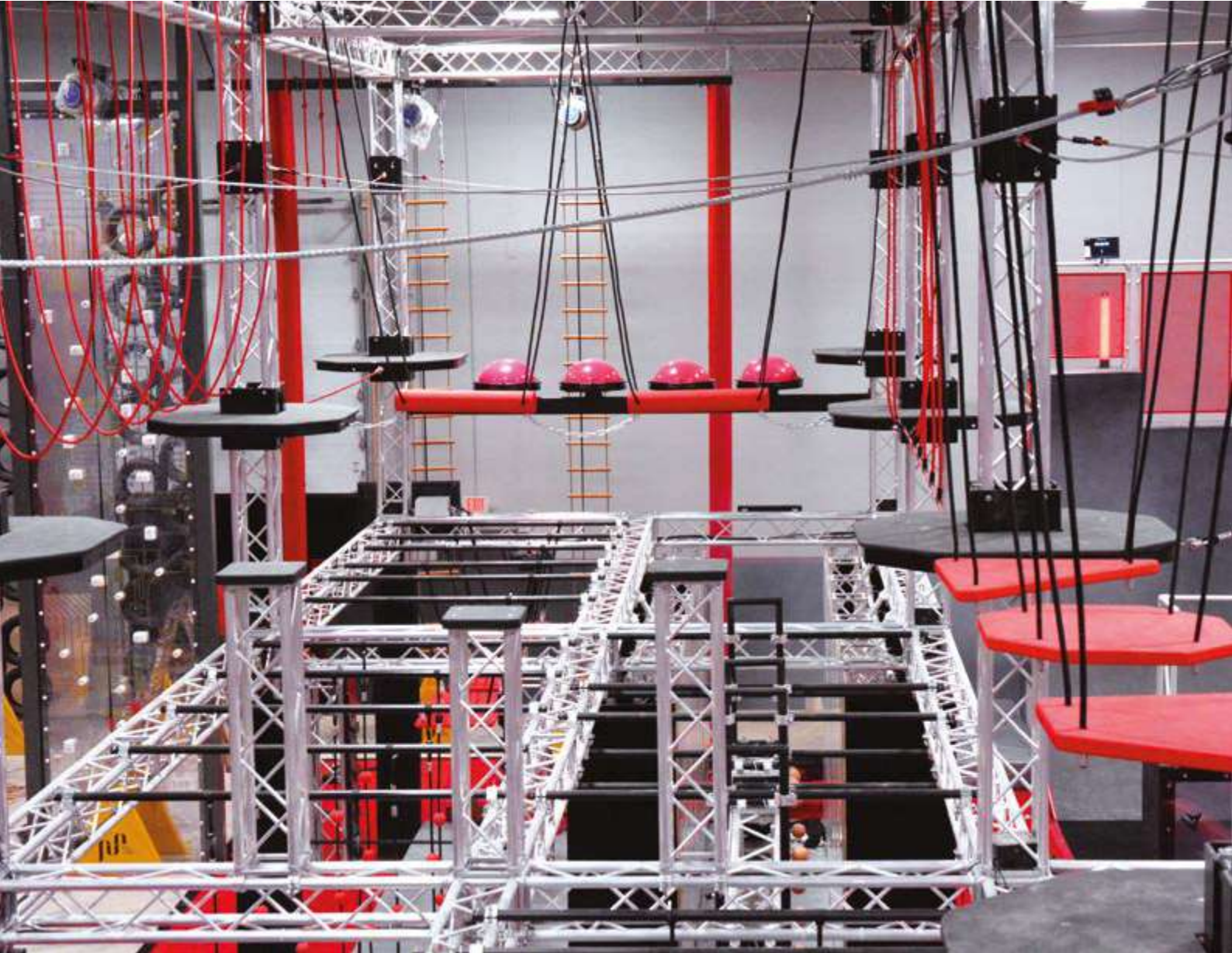

Model: Cube, self standing
Layout: Multi-directional
Operation model: Hourly ticket or day pass
Features: Ninja Course, Climbing walls, Fun Walls

Size: 1000 m² / 10,800 ft²
Optimal capacity: 47 ppl
Level: 1
Obstacles: 28



Adventure Hub

Manama, Bahrain | Family entertainment center



Model: Hex, self-standing
Layout: Multi-directional
Operation model: Day pass
Feature: Fun Walls

Size: 330 m² / 3,500 ft²
Optimal capacity: 48 ppl
Levels: 2
Obstacles: 18



Trapezitsa Park

Veliko Tarnovo, Bulgaria | Adventure park



Model: Hex, self-standing

Layout: Multi-directional

Operation model: Per sessions

Size: 100 m² / 1070 ft²

Optimal capacity: 24 ppl

Levels: 2

Obstacles: 14



Funtopia Naperville

Naperville, IL , USA | Family entertainment center



Model: Cube, self-standing
Layout: Linear
Operation model: Per sessions
Features: Fun Walls, Ninja Course

Size: 200 m² / 2200 ft²
Optimal capacity: 24 ppl
Level: 1
Obstacles: 12





PRODUCT PORTFOLIO

World-renowned for its climbing walls, Walltopia also designs and manufactures a wide range of other active entertainment attractions alongside ropes courses; Fun Walls (interactive climbing walls for children and adults), Ninja Course (challenging obstacle courses), Walltopia Caves (artificial caving systems) and Rollglider (a unique ride that combines the feel of zip-lining, hang-gliding and roller coasting). Walltopia's solutions are conceived to wisely complement each other, effectively forming an exhilarating ecosystem.

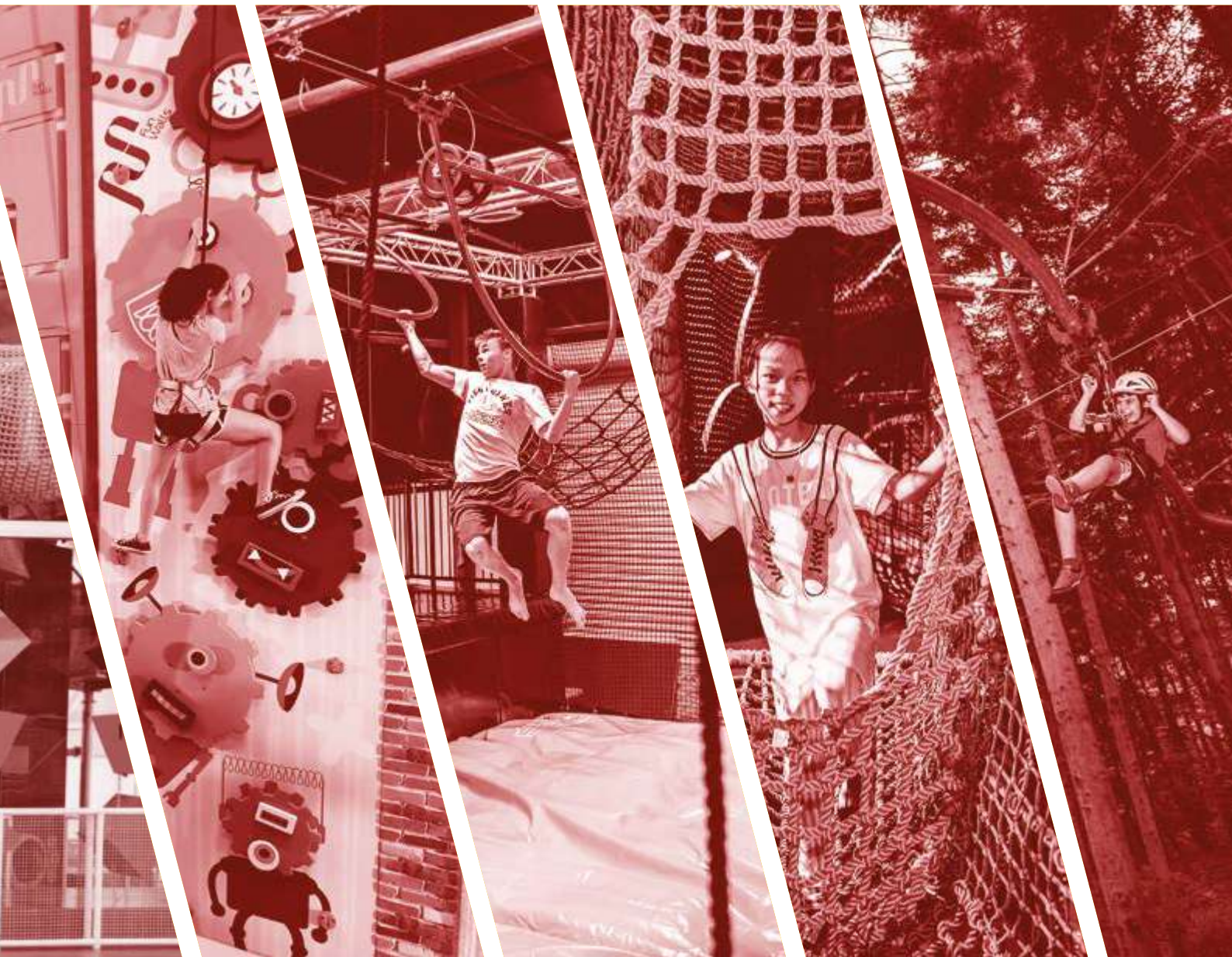

ADVENTURE TRAIL



Walltopia Adventure Trails allow participants to experience the thrill of heights without the need for a harness. Its challenging tunnels of nets and obstacles are a great way to diversify any entertainment center and deliver unique emotions in a safe environment. They can be incorporated into a variety of indoor and outdoor locations suspended from the ceiling, self-standing or attached to other rides or attractions.



ROLLGLIDER



Rollglider is an aerial ride which combines the thrill of zip-lining and hang-gliding into one ride, giving you a new adrenaline experience in a safe environment. The ride can be custom designed to meet all of the needs of the venue with speed options of up to 60 km/h. Rollglider is a great way to increase revenue out of your existing space as it easily utilizes areas that are often left unused such as high ceiling above other attractions or building facades.



Climbing Walls



Innovation has always been our driving force in providing the largest and most complete range of climbing wall surfaces available in the world today. We deliver complete solutions for customers' facilities and businesses from project design to wall assembly and route setting. Thus we have built walls for gyms, schools, universities, shopping centers, hotels and recreational areas as well as for competitions worldwide.

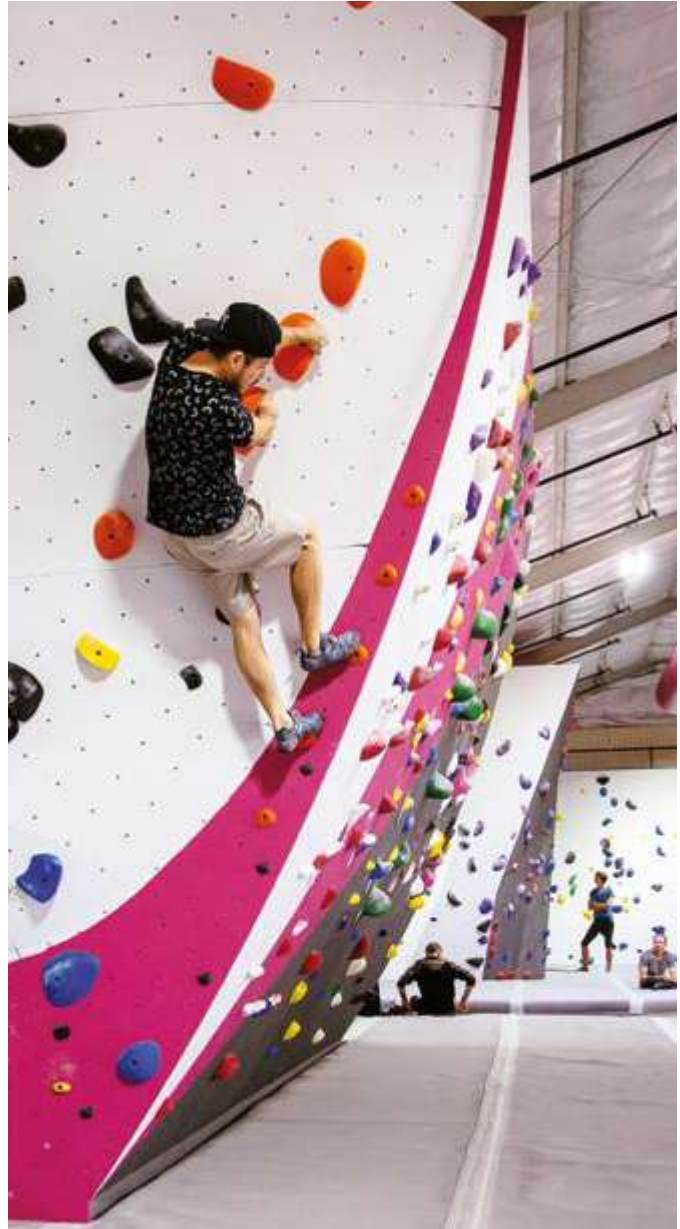

FUN WALLS



Fun Walls are interactive climbing walls that engage both children and adults in the challenge of climbing and the fun of play. Colorful and dynamic, they bring the participants to a world of climbable medieval castles, labyrinths, beanstalks, spider webs, dark chimneys and many more. Fun Walls is an amusement attraction that embraces active entertainment and attracts a very wide public by not requiring any special skills or training.

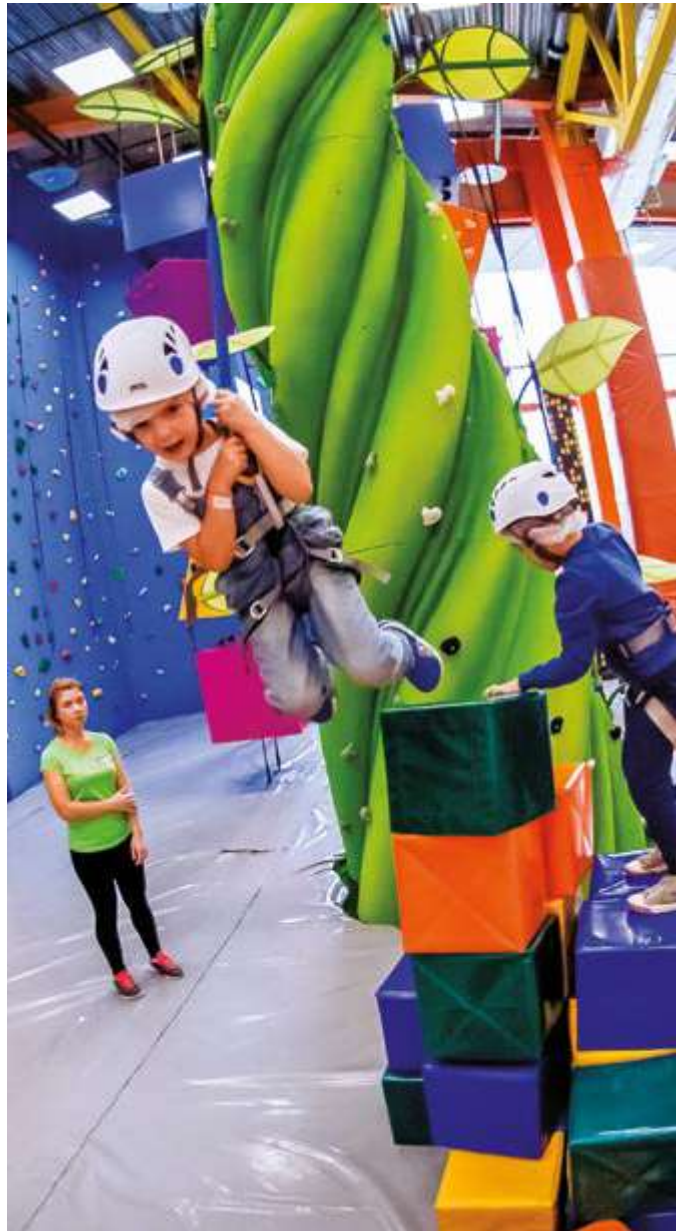



Waltopia designs and manufactures artificial caves which give visitors a realistic and memorable caving experience. Our caves are suitable for both indoor and outdoor locations such as amusement parks, family entertainment centers, gyms, children's playgrounds, ropes course facilities and retail centers. Waltopia Caves provide an excellent opportunity for visitors to explore and test their limits.

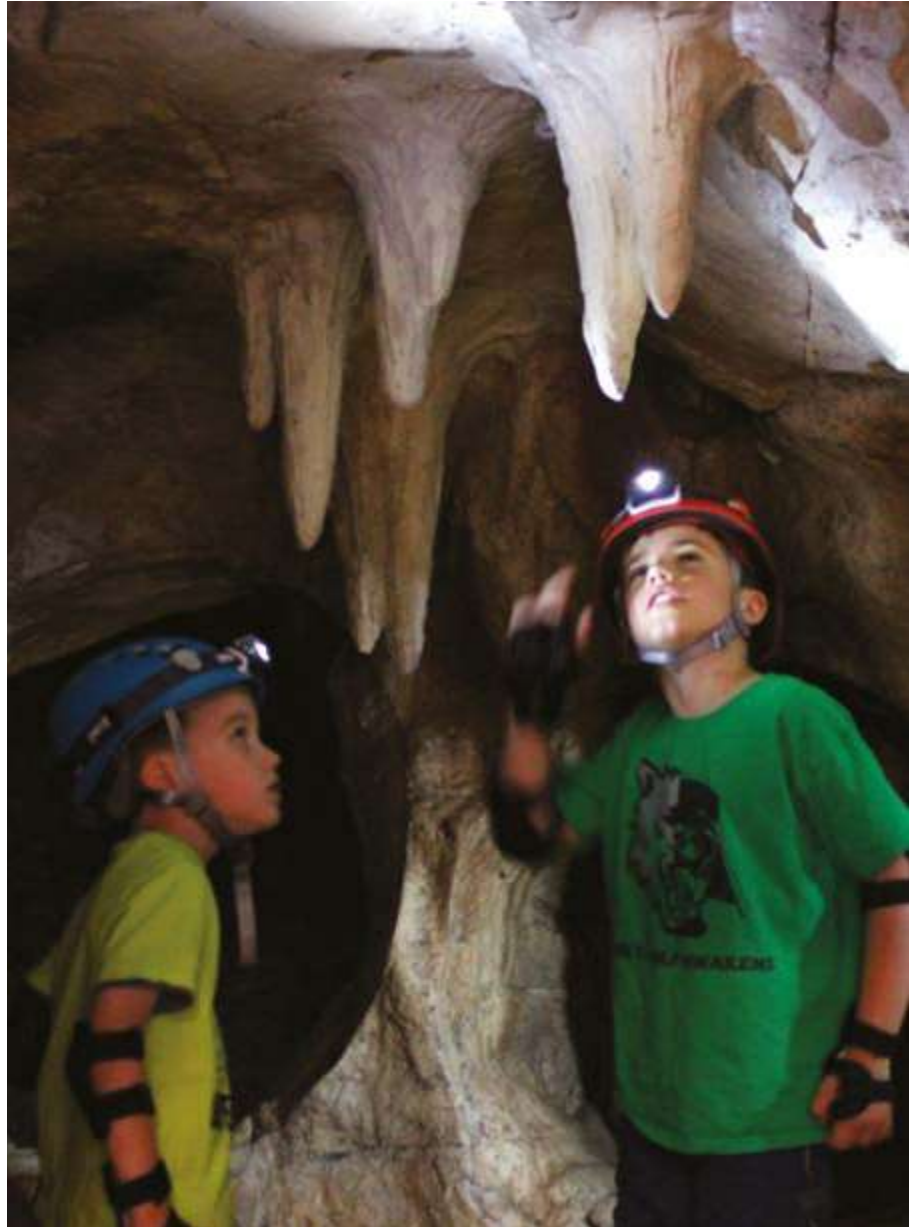

NINJA COURSE



Ninja Course is a modular obstacle course system designed to challenge and improve the strength, endurance, coordination, agility and balance of kids and adults alike. It is a fun activity allowing participants to train, compete and unwind in a safe environment. Its vast variety of obstacles with different difficulty levels makes it challenging for a wide demographic. Ninja Course is a great fit for trampoline parks, FECs, sports centers, training facilities and climbing gyms.



ADVENTURE **HUB**



The Walltopia Adventure Hub is a first-of-a-kind massive entertainment station that provides a unique experience to visitors by combining sport, fun & adventure. It unites Fun Walls' interactive climbing walls, Walltopia's high and low ropes courses, Rocktopia's realistic rockwork and the Rollglider's exciting aerial ride into one massive entertainment facility. It is custom designed and made to fit any indoor or outdoor space while taking up the space of a single attraction.





WALLTOPIA

Head Office:

111 VTsarigradsko Shose blvd.,
1784 Sofia, Bulgaria

E-mail:

adventure@walltopia.com

adventure.walltopia.com